



Special Edition

User Manual / Warranty

COMFYGO
mobility equipment

Table of Contents

Preface	2
Product Performance	3
Safety Instructions	5
Usage and Operation	9
Maintenance Areas	18
Tech Support	21
Warranty	22



Preface

This manual contains the operation, assembly methods, and and simple faults solutions.X-1

Please read the user manual carefully before using this product.

-

The manual applies to our model:

- This manual contains wheelchair maintenance information and self checking methods. Please be sure to keep this manual in a safe location for future reference.
- The annotations and illustrations in this manual may vary slightly from your actual model because we continuously improve and upgrade our components and design.
- Please provide this manual to all users of this wheelchair and make sure all users understand how to operate this wheelchair.
- Please contact with your dealer if there is any ambiguity or questions about this produce or manual.
- Improper use of any vehicle may lead to injury. Unsafe driving could harm yourselves and others.
- The wheelchair is intended to comfortably transport those with walking difficulties or those with limited or no walking abilities.
- This wheelchair is designed to only transport 1 person.



Warning symbol

Follow the instructions next to his symbol closely.

Please pay attention to these instructions, otherwise, it may result in physical harm or damage to the user, wheelchair, or the environment.



1. Product Performance

This series wheelchair is suitable for use at low speeds, on good road conditions, and moderate slopes.

Performance Parameters and Technical Specs, X-	
1 Overall size	41.5" x 26" x 37.5" (1050x660x950mm)
Fold size	31.5" x 15.5" x 30" (800x400x760mm)
Seat size*	17.5" x 17" (450x430mm)
Net weight	37 lbs (16.8 kgs)
Seat height	20.5" (520mm)
Armrest height	8.5" (210mm), from cushion
Backrest height	15.5" (395mm)
Max loading weight	220 lbs (100 kgs)
Front wheel diameter	8 inch (200 mm)
Rear wheel diameter	24 inch (610 mm)
Braking system	Connecting brake
Static stability	10°
Reversing width	≤59 inches (≤1.5m)
Tire pressure	2 kg f/m ²
Obstacle climbing	2 inches (50mm)
Parking brakes	≥8°
Reverse downhill	≤13.75" (350mm)
Min turning back radius	≤33.5 inches (≤850mm)
Max turning back radius	≤59 inches (≤1500mm)
Static stability (Vertical forward)	≥10°
Static stability (Vertical rearward)	≥10°
Static stability (side forward)	≥15°

* seat width is the distance between armrests



1. Product Performance

Main Structure

This series of electric wheelchairs is composed of one main part:

- The Frame: Frame, Wheels, Footrest, Armrests, Backrest, etc.

Application Range

This wheelchair is designed for individuals who have physical disabilities that limits their mobility. This wheelchair is designed to carry individuals weighing less than 100kg (220lbs). This wheelchair is intended to be used as substitution to walking only and is not intended to be used a substitution of a motorized vehicle. This wheelchair is intended to be used indoors and outdoors in a safe and suitable location.

- 1 - Armrest
- 2 - Hand rim
- 3 - Castor
- 4 - Leg rest (Footrest)
- 5 - Front rigging
- 6 - Anti rolling wheel
- 7 - Caregiver handles



WARNING

People with the following conditions should not operate this vehicle:

- Unresponsive upper limbs
- Suffering from senility or dementia
- Unable to take care of themselves
- Use restricted by a medical professional

2. Safety Instructions

General Riding Cautions

- While using this wheelchair, keep your hands on the hand rims to properly control the wheelchair.
- To avoid injury, first practice using this wheelchair in a safe and open environment, such as a park. Practice moving forward, backward, stopping, and turning. As you gain skill and become comfortable with the controls, you can begin to use this wheelchair in other suitable environments.
- Before riding on any roads, be sure to have a caregiver with you and be sure to always ride safely.
- Please follow all pedestrian traffic rules, the wheelchair is not considered an automobile.
- Please ride on the sidewalk and the zebra crossings only. Do not ride on vehicle lanes.
- Ride at steady speeds and avoid sharp turns or zig zagging.
- If provided, please fasten the seat belt while in use.
- Solid rubber tires need minimal maintenance but should be cleaned occasionally with a damp cloth. Replace tires if they become severely worn or cracked.

Avoid Riding in These Conditions Unless Accompanied by a Caretaker

- Riding in inclement weather such as rain, heavy fog, strong winds, snow, etc. If your wheelchair gets wet, some functions may be damaged so please wipe off all water immediately.
- Riding in sub optimal conditions such as muddy areas, trails, sand, gravel, etc.
- Riding in crowded areas, riding on unfenced roads, near ditches, near bodies of water, or near any other dangerous areas.
- Riding over railroad tracks. If you must cross a railroad track, inspect the tracks to confirm it is safe to cross. Cross at an angle that ensures your tires will not get stuck in the track.
- Carrying people or cargo. This wheelchair is designed to be used by only one person. It is not designed to carry additional people or cargo.



2. Safety Instructions

Precautions for Uphill and Downhill

- Avoid riding on steep hills, uneven surfaces, high steps, channels or any other steep areas.
- Avoid riding on steep slopes, the slope range should be less than 8 degrees.
- Use brakes during downhill descent.
- Avoid driving sideways on steep areas.
- Avoid riding on or nearby stairs.
- Avoid crossing ditches.
- If you must cross a ditch, try to cross at a 90° angle.



If the wheelchair malfunctions at traffic crossing, please immediately ask passersby for help.

Precautions for Caregivers

- Caregivers should confirm that the users' feet are in the proper position on the footrest.
- Caregivers should make sure the user is in the seat properly and that the user is properly secured
- Caregivers should confirm that there are no loose clothing articles that can get tangled in the wheels.
- Caregivers should use caution while pushing the wheelchair and be mindful of the surrounding environment at all times to avoid injury.

Other Important Notices

Repair and Refit

Repair and Reform:

If a repair or modification is necessary, please contact your dealer. Do not modify this wheelchair yourself, it may lead to injury or malfunction.

Protect Environment: In order to protect environment, do not casually discard the wheelchair.

Keep the Storage Environment Dry: Do not store wheelchair in damp conditions, such as near a bathroom. If the wheelchair gets wet, wipe the water off immediately.



2. Safety Instructions

Compatibility with Other Devices

The wheelchairs should not be used together in conjunction with any other devices. If you need to connect a device to it, please contact ComfyGO Mobility, so that we may confirm that the wheelchair will not be adversely affected.

Service Lifetime

- The service lifetime is 5 years from date of manufacture. To avoid injury or accidents, users should not use this wheelchair for more than the service lifetime.

- *Do not replace parts or material randomly.*
- *Do not add weight randomly, as it may cause an imbalance.*
- *If there are abnormal sounds coming from the wheelchair, contact service immediately.*
- *Do not operate your wheelchair without completely reading and understanding this user manual.*
- *Do not lean over the top of the back upholstery to reach objects from behind as this may cause the wheelchair to tip over.*
- *Do not shift your weight or sitting position toward the direction you are reaching as the wheelchair may tip over backwards or sideways.*
- *Do not stand on the frame of the wheelchair.*
- *Do not operate the wheelchair unless the wheelchair and its adjustable components and accessories are in a safe configuration(s).*
- *Do operate the wheelchair in the most stable position. The user/care giver should ensure that the angle(s) (and/or height) of the seat and seatback while tilted, raised, or reclined are not beyond the wheelchair's maximum safe angle(s) as noted in the performance testing disclosure section and the Manufacturer specification sheet.*
- *Always use caution when transferring in or out of the wheelchair. Every precaution should be taken to reduce the transfer distance. Be certain the wheel locks are engaged to prevent the wheels from moving.*



2. Safety Instructions

- *The product is not intended for persons with visual impairment.*
- *The driver needs to be mentally and physically suitable to drive the wheelchair.*
- *The safety of using this wheelchair as a substitution to a seat in a motor vehicle has not been established. Serious injury could occur to the user and surrounding persons.*
- *The wheelchair should be in its most stable position prior to entering or exiting the wheelchair seat.*
- *Environmental conditions may affect the safety and performance of your wheelchair.*
- *Incorrect repair and/or servicing of this wheelchair performed by users/caregivers or unqualified technicians can result in death, serious injury, or damage.*
- *Do not carry passengers on your wheelchair.*
- *The wheelchair is not intended for use on roads, streets, or highways.*
- *Do not use on an escalator. Serious bodily injury may occur.*
- *Do not use while lifting weights.*
- *Do not use while under the influence of alcohol or medication/drugs. This may impair your ability to operate the device. Please consult your physician regarding the use of your medications.*
- *This device is not safe for use with or around a MRI machine. Do not use in the vicinity of a MRI machine.*
- *We strongly recommend using anti-tippers.*



3. Usage and Operation

3.1 Wheelchair Adjustments

Folding Your Wheelchair

Step 1: Pull the joint switches back and pull down both rear handles (Picture 1).

Step 2: Pull the seat cushion up with your hands and push the wheelchair inwards (Picture 2).

Unfolding Your Wheelchair : When the wheelchair is partially apart, pull the armrests apart while pushing the seat cushion down until you hear the seat click into place. Lift both rear handles until you hear them click into place. Before using your wheelchair, make sure that the seat and handles are in their locked positions. (Picture 3)

 *Avoid using extreme force while folding or unfolding as it may damage the wheelchair. To avoid injury, keep your hands away from the frame and frame joints during the folding and unfolding process. (Picture 4)*

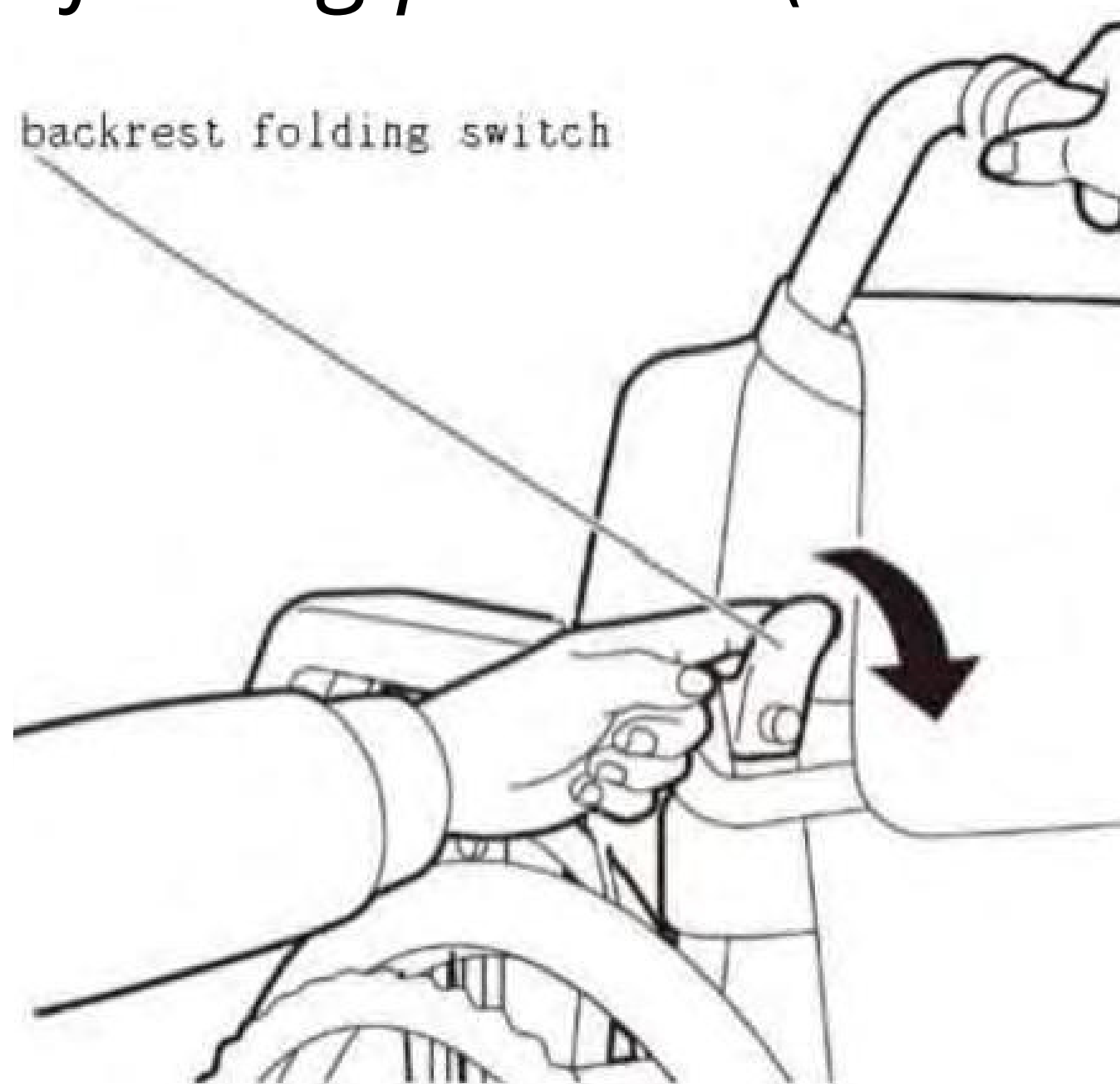

Picture 1



Picture 2

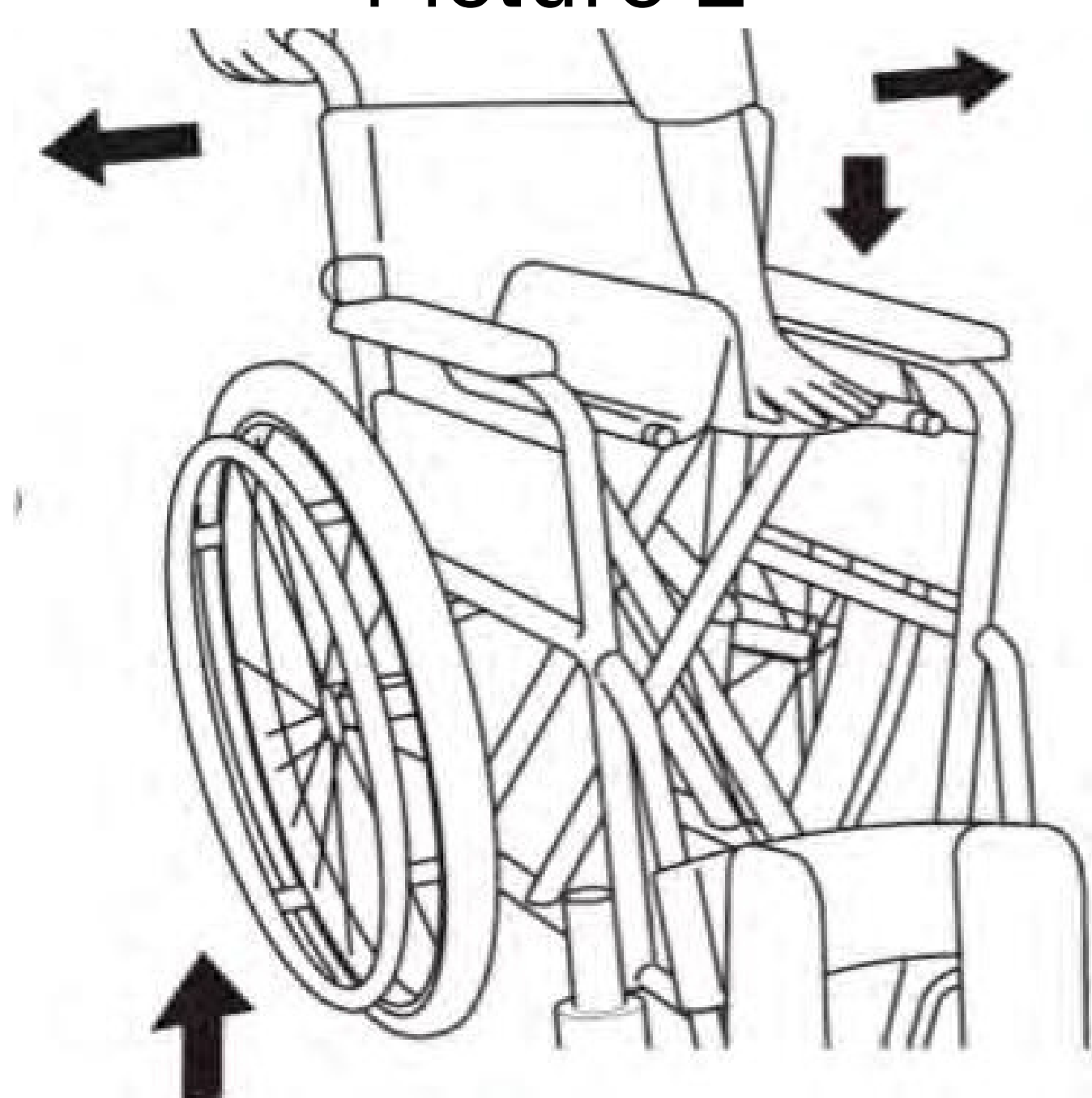

Picture 3

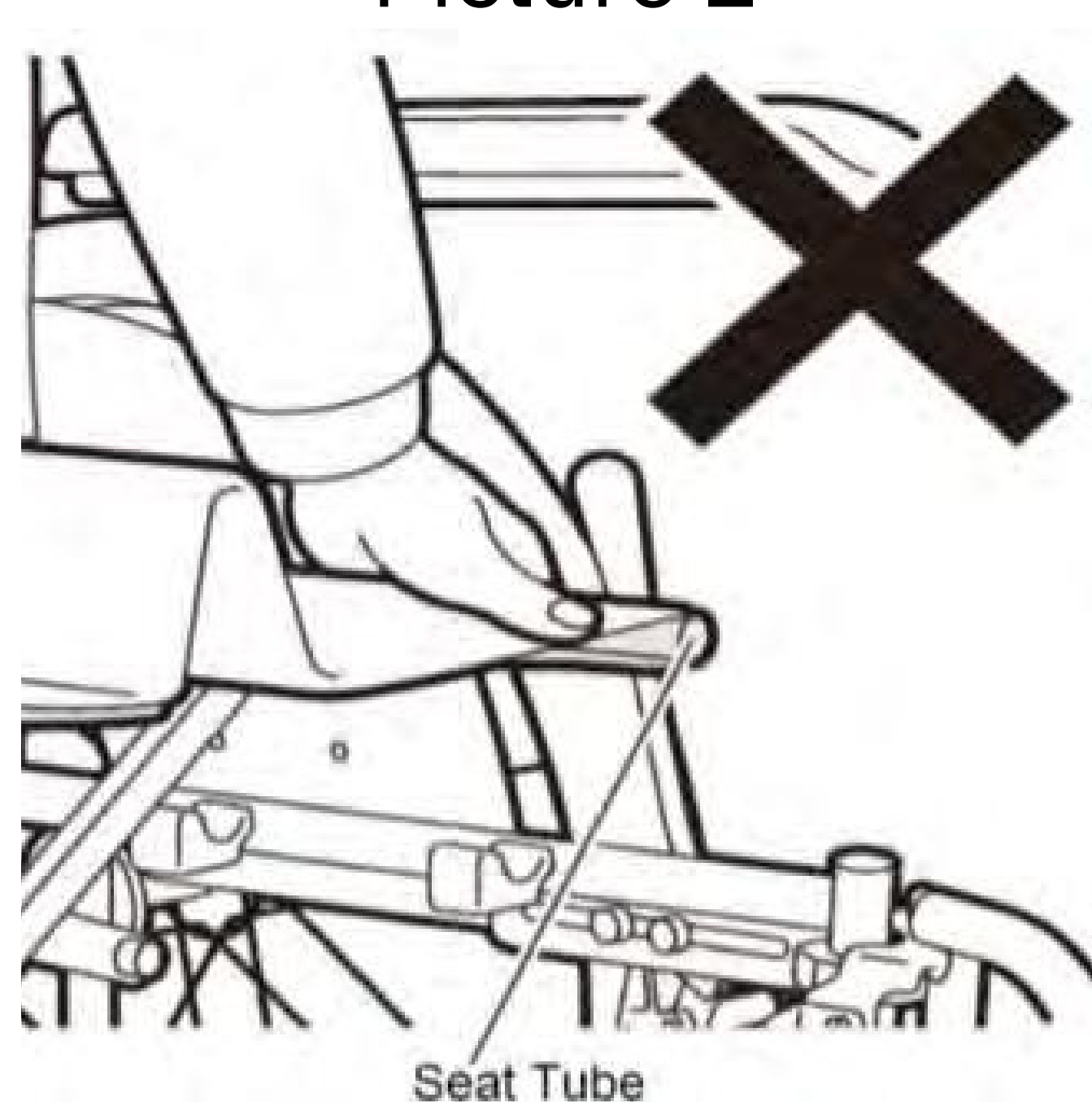

Picture 4



3. Usage and Operation

Assemble and Disassemble the Footrest

Install the footrest into the frame tube and push the footrest into the fixed position. To disassemble, lift the footrest puller then turn the footrest outwards then lift the footrest (Picture 5 and 6)



Picture 5 Picture 6

When adjusting the length of the footrest, the user should sit in the wheelchair with their feet on the foot plates to determine if an adjustment is needed. To adjust the footrest, loosen the bolt on the frame near the support assembly. Raise or lower the foot plate to the desired position that will provide maximum support to your legs. Front rigging should not be so low that it causes an uncomfortable pressure to your thigh area. The footrest should not be lower than 2 1/2" from the ground to ensure proper clearance.

Parking brake

Push the brake handle forward to lock the wheels into place. Pull the brake handle back to disengage the brakes. (Picture 7)

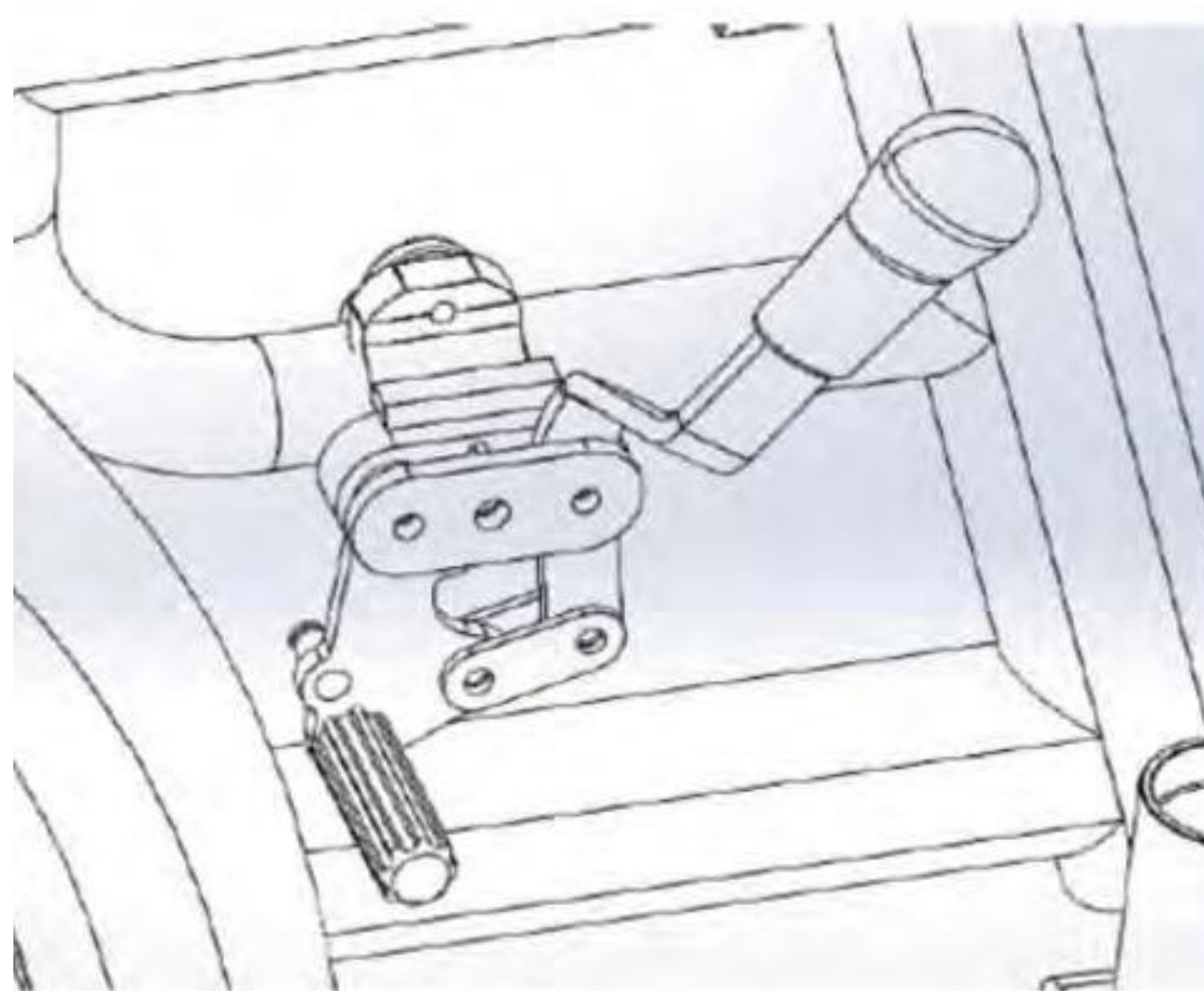

Picture 7

The parking brake is intended for use when parking your wheelchair for long periods of time. It is not recommended to use the brake while in motion or as a turning device. Both brakes need to be engaged at the same time. Be certain that the wheelchair is on a flat surface before releasing the brakes. When releasing the brakes, immediately place both hands on each hand rim to ensure control of the wheelchair.



3. Usage and Operation

Install and Dismantle the Anti-tipper

Pull the switch to install or uninstall the anti-tipper (Picture 8 and 9).



Picture 8



Picture 9



Before the first use, please adjust the anti-tipper to a proper setting that won't allow the wheelchair to tip backwards. When this wheelchair is delivered to you, the anti-tipper is preset to the highest position which does not provide any anti-tip functionality. With the wheelchair in the unfolded position, pull the switch to lower the anti-tipper shaft to the desired position.

Castors

Front castors and wheel bearings should be checked periodically and lubricated if needed.

Leg rests (Footrest) Installation

Lock the rotation shaft in footrest tube, lift the footrest puller, and rotate the footrest from outside to the middle so that the footrest bar is pointing forward. When the footrest puller locks into place, the footrest is in the proper position to use the wheelchair (Picture 10).

The footplate height is adjustable at 25mm per level. User can select a comfortable height then secure the footrest in the desired height (Picture 11). To adjust the height, use a hex wrench and unscrew the hex bolt. Adjust the footplate to the desired height. Reinsert the hex bolt and tighten.



Do not use the wheelchair if the footrest puller is loose or not locked into place.



3. Usage and Operation

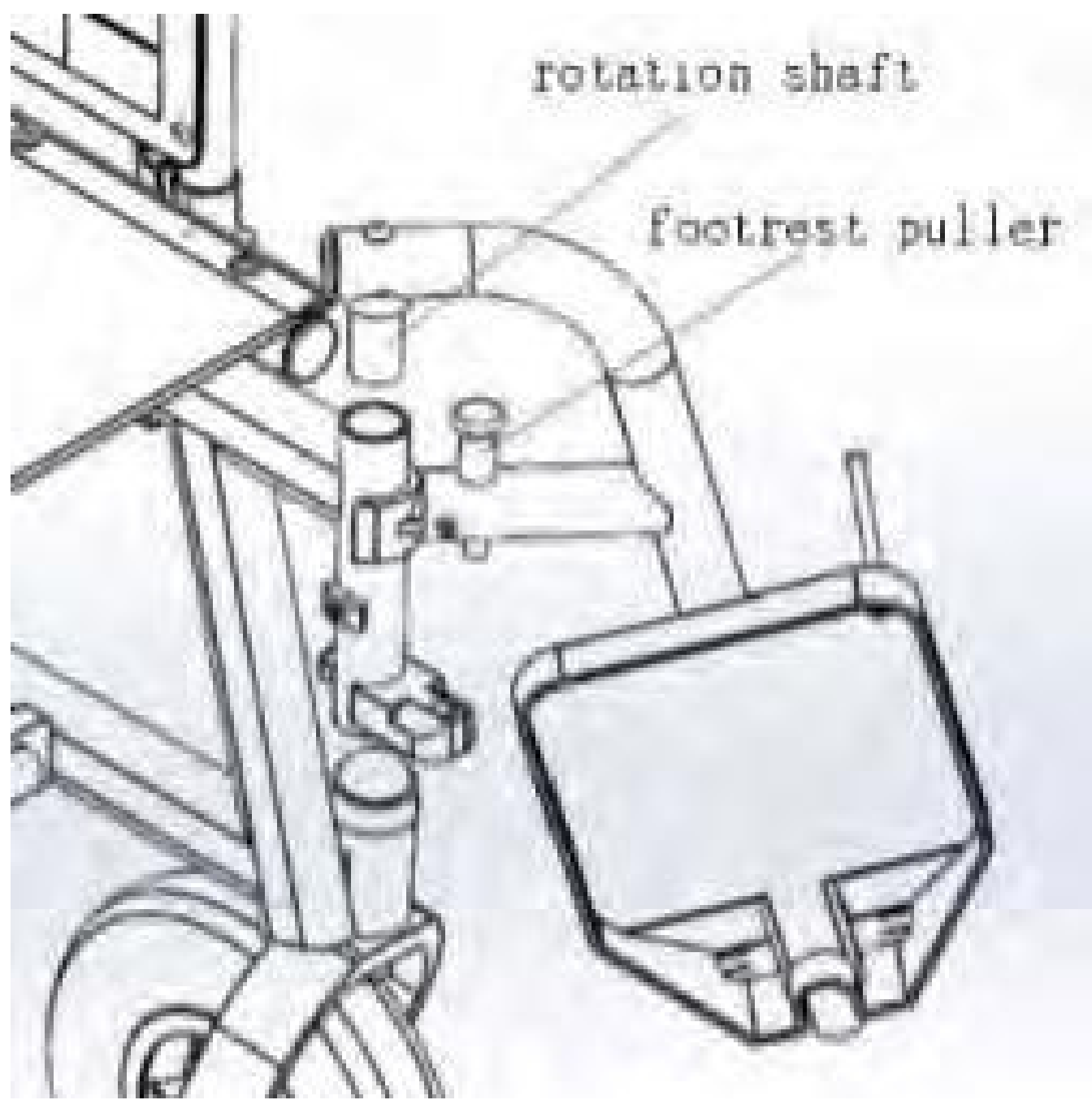

Picture 10 Picture 11

When adjusting length of foot rests or leg rests, user should be sitting in wheelchair with feet on the foot plates. Loosen bolt on the clamp around support assembly. Raise or lower foot plate to desired position that will provide maximum support of thighs. Front rigging should not be so low that it causes uncomfortable pressure to thighs at front of seat upholstery. Footrest should not be lower than 2½" from the ground to ensure clearance. Lift foot plate on leg rest assembly to desired position.

Raising and Lowering the Armrest

To raise the armrest, press the armrest button near the armrest frame and lift the armrest (Picture 12). To lower the armrest simply push the armrest down until you hear a click.



Picture 12



3. Usage and Operation

Getting on and off the wheelchair

When getting on or off wheelchair, please make sure that the front castors are set in the backwards position as to not interfere with your feet, both parking brakes are engaged, and the footplates are folded up. Place your hands on the armrest when getting on or off the wheelchair. If you are finding it difficult to get on or off the wheelchair, please ask a caregiver for assistance.

If you cannot perform the transfer in a safe manner, please ask someone to assist you.

- 1) Position the wheelchair as close as possible to a chair, couch, or bed from which you wish to transfer from.
- 2) Check that both wheelchair brakes are in the locked position.
- 3) Fold the footplates upwards to prevent standing on them during the transfer. (Standing on the footplate increases the risk of injury as the chair may tip over)
- 4) If transferring from the side of the wheelchair, lift the armrest up so that the armrest is not in your way.
- 5) Transfer to/from the wheelchair.



Picture 13

3. Usage and Operation

Riding the wheelchair

If your wheelchair is equipped with a safety belt, please make sure to fasten your safety belt while in use to prevent falling out of the wheelchair.

When sitting in the wheelchair, position yourself as far back as possible in the wheelchair so that your back is touching the backrest. Your upper leg should be horizontal while sitting in the chair and your legs should feel comfortable.

1) When you are comfortably in the wheelchair, release the brakes if it is safe to do so.

2) After releasing the brakes, place both hands on the highest position of the hand rim.

3) To move forward, push both hands forward on the hand rim. To reverse, pull both hands backwards on the hand rim.

4) For continuous movement in either direction, while in motion, release your grip on the hand rims and gently grab the top of the hand rim again and continue your hand movement. Repeating this step will allow you to move the wheelchair over long distances.

5) To turn the wheelchair, apply more pressure to one of the hand rims than the other. For example, if you wish to turn right, apply more forward pressure to the left-hand rim. If you wish to turn left, apply more forward pressure to the right-hand rim.

- Your wheelchair is designed to provide optimum stability under normal driving conditions such as dry and level concrete or asphalt.

- Avoid driving on uneven terrain and/or soft surfaces

- Avoid tall grass that can entangle the wheels

- Avoid loosely packed gravel and sand

- Avoid uneven surfaces

- Do not use your wheelchair at the edge of a stream, lake, or ocean

- Please lock the wheelchair by pulling the manual brake in both sides before adjusting positions.

- To avoid injury, pay close attention to make sure that your fingers or hands are not caught by in the wheels spokes or pinched between the hand rim and rear wheel.

- Be careful when driving in hot or cold environments as this may affect your ability to move the wheelchair. If the surface area of the chair is extremely hot or cold, please allow sufficient time for the surface are to get to an appropriate temperature before getting on your wheelchair.





3. Usage and Operation

Moving on inclines and declines

- 1) If your wheelchair comes equipped with a safety belt, please wear it when in motion
- 2) Avoid riding on steep inclines or declines. The maximum incline/decline angle for this wheelchair is 8 degrees
- 3) If possible, have an attendant or caregiver with you when riding on slopes
- 4) When on an incline slope, lean slightly forward to move your center of gravity forwards. When on a decline slope, sit back in the chair to move your center of gravity backwards.



Picture 14

-  *Control your speed – DO NOT use too much speed on an incline or decline. Use only what is necessary to traverse the incline or decline*
-  *Consider the capacities of your attendant/caregiver – If your attendant or caregiver does not have enough strength to control the wheelchair, be sure to use your speed and brakes accordingly to control the wheelchair*
-  *Risk of tipping over – When on an incline, lean slightly forward to move your center of gravity forwards. When on a decline slope, sit back in the chair to move your center of gravity backwards.*



3. Usage and Operation

Climbing Steps or Curbs

- Riding up low steps or curbs can be done by moving forward up the curb at a low speed. Make sure to keep your hands on the hand rims as you ascend and make sure that the footplates do not touch step or curb. After the front tires are firmly on the step or curb, continue to move forward so that the rear tires move safely up the curb.
- Riding down low curbs can be done by moving forward down the curb at a low speed. Make sure to keep your hands on the hand rims as you descend and make sure that the footplates do not touch the ground. After the front tires are firmly on the ground, continue to move forward so that the rear tires move safely down the curb.

 *Risk of tipping over – If you do not have enough experience on controlling the wheelchair over bumps or curbs, please get help from an attendant or caregiver.*

Transporting the Wheelchair in the car:

To transport the wheelchair in the car, please following below steps:

- 1) If necessary, remove footrests and other accessories from the wheelchair.
- 2) Store footrests and accessories in a safe location
- 3) Fold the wheelchair if necessary (page 10)
- 4) Place the wheelchair in the storage compartment.

 *Risk of injury – To avoid an injury caused by sudden braking, make sure that the wheelchair is properly secured so that the wheelchair is unable to shift or move during transportation.*



4. Maintenance Areas

Maintaining Your Wheelchair

Maintenance of wheelchair includes general cleaning of the wheelchair, checking and tightening all nuts and bolts. Checking the wheels and tires. Checking the battery, battery cables, and battery connections. Checking the battery charge level. For further maintenance, please contact with your dealer. It's suggested to perform a general maintenance check once per month. It's also recommended to check with your dealer annually to conduct a full systems check.

Cleaning Your Wheelchair

- Please clean the wheelchair regularly.
- Clean the parts that are frequently touched by the user (seat cushions, armrests, controller, etc.) by using a gentle cleaner and clean cloth. Do not use organic solvents to clean. At minimum, the wheelchair should be cleaned once per week. If the wheelchair is used by an infectious user, it should be cleaned and disinfected immediately after each.

Wheels

Check the condition of the tires regularly. If the tire tread pattern depth is less than 1mm, please replace with new tires. Regularly check and tighten the nuts and bolts on the wheel.

Maintenance Checking

The following is a maintenance checklist. The wheelchair should be checked according to our suggestion.

Before each use, check if following parts are functioning correctly:

1. Backrest
2. Armrest
3. Controller position
4. Footrest
5. Tires
6. Brakes



4. Maintenance Areas

Regularly check these parts to avoid losing parts or causing excessive wear and tear.

1. Screws, nuts, and bolts
2. Brakes and brake lever
3. The front and rear wheels and tire tread depth
4. Wheel axles
5. Backrest adjusting system (for wheelchairs with reclining feature)
6. Other adjusting systems

Storage and transportation

- 1) Before use, please check if any parts are loose or missing.
- 2) Wheelchair should be covered and labeled.
- 3) Avoid moisture and direct sunlight and keep the wheelchair away from heat sources.
- 4) Do not store outdoors.
- 5) Storage conditions
 - Storage environment no to exceed (-40 Celsius to +55 Celsius or -47 Fahrenheit to 131 Fahrenheit)
 - Relative humidity $\leq 80\%$

Care and Cleaning

- 1) Seat and backrest
 - Clean seat and backrest with damp cloth, but do not soak the seat and back cushion.
 - Use a mild detergent for removing stubborn dirt.
 - Stains can be removed by using a sponge or a soft brush.
 - Do not use strong cleaning liquids such as solvents and do not use hard brushes or sharp-edged objects.
 - Do not clean with steam or pressure washers.
- 2) Plastic parts

Clean the plastic parts of your wheelchair with a mild plastic cleaner. Use a sponge soft brush. Plastic parts include the arm pads, splash guards, footplates, handgrips, and tires.



4. Maintenance Areas

3) Coating

The high quality of the surface layer guarantees optimal protection against corrosion. When cleaning, use warm water, mild detergents and a sponge or soft brush. Be sure that no wetness gets into the tubes or frame.

4) Inspection

We recommend one full inspection every year and general inspections before each use. The following checks are recommended during a full inspection and should be documented by the user or authorized person.

- Check the frame parts and the hinged tubes for plastic deformation, cracks and impaired functioning.
- Visually check for damage to the paintwork (danger of corrosion).
- Check the operation of the wheels (free running, level rolling, axle play, tires, profile, condition of the rims, floating axles, etc.).
- Check the solidity and tightness of all screws, bolts and nuts.
- Verify adequate amounts of grease on all metal joints and movable parts.
- The condition of the axles of the main steering wheels.
- Visually check all plastic parts for cracks or brittle spots.
- Functionality of the armrests, splash guards, and footrests.
- Functionality of all adjusting mechanisms, levers and adjusting screws.
- Operation of other detachable parts (example: anti-tipper, personal safety belt, backrest, seat, etc.).

6. Warranty Policy

- Our goal is to ensure that you are delighted with your purchase.
- According to our warranty agreement, all new products have a limited warranty. All batteries have a six-month warranty. Spare parts have a one-year warranty. The limited warranty does not include labor or device failure due to the owner's misuse or negligence, non-durable components and components subject to normal wear and tear that need replacement from time to time (for example rubber materials, accessories, wheels or brakes, and plastic parts). All warranty claims require proof of purchase and the serial number.

Note that your warranty does not cover these conditions:

- Functional problems: Issues related to normal use and aging such as surface coating and plating, natural fading of resins
- Replacement of consumable materials due to wear and tear, such as tires, fuses, plastic parts, glass parts, lubricates etc.
- Any fees for Inspection, adjustment, adding oil, cleaning, etc.
- Fees for service and maintenance performed dealers as specified by our factory
- Any unauthorized modifications
- Maintenance costs at any unauthorized service centers
- If you fail to regularly check the issues as specified in this manual page 18-20
- Improper or wrong maintenance
- If unauthorized maintenance has been performed
- Operating differently than what is described in our manual or if you overload the wheelchair
- Any unauthorized modifications to the wheelchair
- External factors such as: soot, pharmaceuticals, bird droppings, acid rain, flying stone, metal powder, etc.
- Natural disasters such as: typhoons, floods, fires, earthquakes etc. damaging the unit

Protect the Environment

- Please do not dispose of this wheelchair or its components. Instead, please return them to our service center or follow your local disposal regulation.

