

30x60WCA SLIDE-IN Pelican



*RIGHT HAND SIDE SHOWN
 **FAUCETS NOT INCLUDED
 ***REMOVEABLE BOTTOM PANEL FOR HOYER
 LIFT ACCESS

DESCRIPTION

Meditub's 30x60WCA (Wheelchair Accessible) Slide-In Tub is constructed of the highest grade fiberglass composites with a triple gel coat finish for beauty and durability. The 30x60WCA Slide-In Tub is perfect for new construction and retro fitting because of its industry standard size. It comes with a stainless steel frame for a long lasting strength and adjustable feet for easy installation and leveling.

FEATURES

AVAILABLE COLORS.....	WHITE/ BISCUIT	SEAT HEIGHT.....	21"
MATERIAL.....	HIGH GLOSS FIBERGLASS WITH TRIPLE GEL COAT FINISH	SEAT CONTOURED.....	YES
DOOR SWING OUTWARD/INWARD.....	OUTWARD	AIR SYSTEM AVAILABLE.....	YES
ENCLOSED ON THREE SIDES.....	YES	HYDRO SYSTEM AVAILABLE.....	YES
DOOR SIDE.....	LEFT OR RIGHT	DUAL SYSTEM AVAILABLE.....	YES
DIMENSIONS.....	30(W)X60(L)X42(H)	SAFETY GRAB BAR.....	YES
MAX CAPACITY (GALLONS).....	65 GALLONS	NON SLIP FLOOR.....	YES
SEAT.....	YES	FAUCET DECK.....	YES
		APPROX. UNIT WEIGHT.....	245 Lbs
		APPROX. SHIPPING WEIGHT.....	295 Lbs

OPTIONS

WHIRLPOOL SYSTEM

Pneumatic Control for Pump
 1 HP Electric Water Pump Motor
 6 Directional and Adjustable Water Jets (Color Coordinated)
 Inline Heater (Maintains Water Temperature)
Note: All of our water massage jets have a 360° range of motion to provide maximum comfort and versatility. The Inline Heater is designed to maintain water temperature during water jet operation.

AIR SYSTEM

Pneumatic Control for Pump
 1 HP Electric Air Pump Motor
 Air Jet Blower w/ Inline Heater
 16 Air Jets (Color coordinated)
 Self Purging

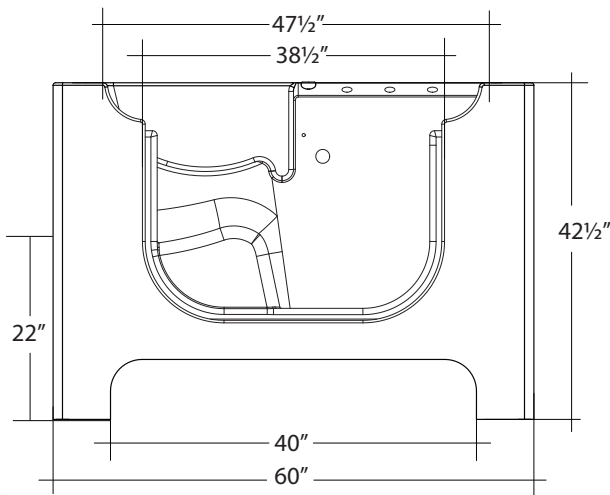

***REMOVEABLE BOTTOM PANEL FOR HOYER LIFT ACCESS

DUAL SYSTEM

Combines Air and Whirlpool Systems

AROMATHERAPY

Get ready to be swept away to your special place as the scent of flowers or herbs permeate your senses and bring peace and comfort into your day.

CHROMATHERAPY

An LED lighting system that transforms your bath into a sanctuary for escape and mind-lifting bliss.

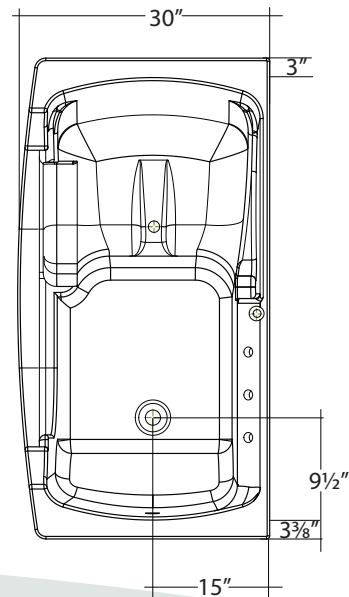

SKU VARIATIONS

MT3060WCALWS Left, White, Soaker	MT3060WCARWS Right, White, Soaker	MT3060WCALBS Left, Biscuit, Soaker	MT3060WCARBS Right, Biscuit, Soaker	MT3060WCALWH Left, White, Hydro Therapy	MT3060WCARWH Right, White, Hydro Therapy
MT3060WCALBH Left, Biscuit, Hydro Therapy	MT3060WCARBH Right, Biscuit, Hydro Therapy	MT3060WCALWA Left, White, Air Bubble Massage	MT3060WCARWA Right, White, Air Bubble Massage	MT3060WCALBA Left, Biscuit, Air Bubble Massage	MT3060WCARBA Right, Biscuit, Air Bubble Massage
MT3060WCALWD Left, White, Dual Hydro & Air System	MT3060WCARWD Right, White, Dual Hydro & Air System	MT3060WCALBD Left, Biscuit, Dual Hydro & Air System	MT3060WCARBD Right, Biscuit, Dual Hydro & Air System		