

### Thank you for your order!

We are confident that you will enjoy your Wall-Mounted Teak Bench for many years to come. An essential part of your satisfaction is properly mounting the bench. Failure to do so may result in injury to you or a loved one.

If you are missing any of the hardware or any of the components appear to be damaged, please contact Teakworks4u immediately. Do not attempt to mount the bench until any missing hardware or damage is corrected.

#### NOTE:

These instructions are for our stock products only, if you have purchased a custom product please use this only as a guide as your measurements may differ. If you have any questions regarding the installation of your custom product please contact us.

#### The tools you need are:

Stud Finder, Drill, 5/32" drill bit, #3 Phillips Screwdriver, 6" #3 Phillips Bit Extension, 12" or longer Level, Tape Measure, and a Pencil.

**Before beginning, check your box.** It should contain the bench with pre-attached mounting brackets and a hardware pack containing 6 #12x2-1/2" Marine Grade Stainless Steel Phillips head screws. Test the bench locking mechanisms to be sure that they operate properly. Pressing the tang at the front of bench will activate the mechanism.

#### Step 1

Select the location for mounting the bench. Keep in mind that this bench is collapsible so be sure that there is enough clearance for proper operation of the adjustment mechanism.

#### Step 2

Following the manufacturer's instructions for your electronic stud sensor, locate the wall studs. Depending on the type of stud sensor you have, you can also use it to locate any electrical wires or other obstructions in the wall. If you find electrical wires, water pipes or any other obstructions, it is best to choose a different location for your bench.

**WARNING:** You must mount your bench directly into the center of your wall's wooden studs. DO NOT attempt to mount into steel studs or with any type of wall anchor. This will not provide adequate support.

#### Step 3

Measure up from the floor to the desired height of the bench. We recommend a minimum of 13" to a maximum of 18" but you can vary this according to your specific requirements. Make a mark on the wall for the height. Using your level, mark a level horizontal line to reference as you continue.

**WARNING:** Be sure to include the thickness of the bench in your measurement calculations.



#### Step 4

For easier mounting, the brackets on your bench are located at 16" on center, the same as most wall studs. Using the template at left, mark the locations of the mounting holes for each bracket. You can also have someone hold the bench in position while you mark the holes directly from the bracket.

#### Step 5

Using a drill and a 5/32" bit, drill pilot holes in the wall being sure to stay centered on the stud. Be sure to check that all of the pilot holes line up with the bracket before proceeding. Make any necessary adjustments.

#### Step 6

Again, have someone hold the shelf in place while you set the screws in place. Use a #3 Phillips screwdriver to set the screws in part way. Double-check the level of the bench. This is your last chance to make any minor adjustments. Once you're satisfied with the level, using your power drill fitted with a #3 Phillips bit (you may need the 6" extension bit at this point), drive the screws firmly against the wall brackets. Do not over-tighten as this can compromise the strength of the bracket. Hand test all of the screws to be sure that they are solidly set in place.

#### Step 7

Test the locking mechanism of the mounted bench, ensuring that the bench can be raised and lowered easily.

#### Step 8

Load test the bench to confirm secure mounting.

#### CAUTION:

You must adhere to your local building codes. If you are in doubt or feel unsure about mounting the bench yourself, contact a licensed contractor.

**\*\*Cut out to make  
sure screws are  
in the correct spot.**

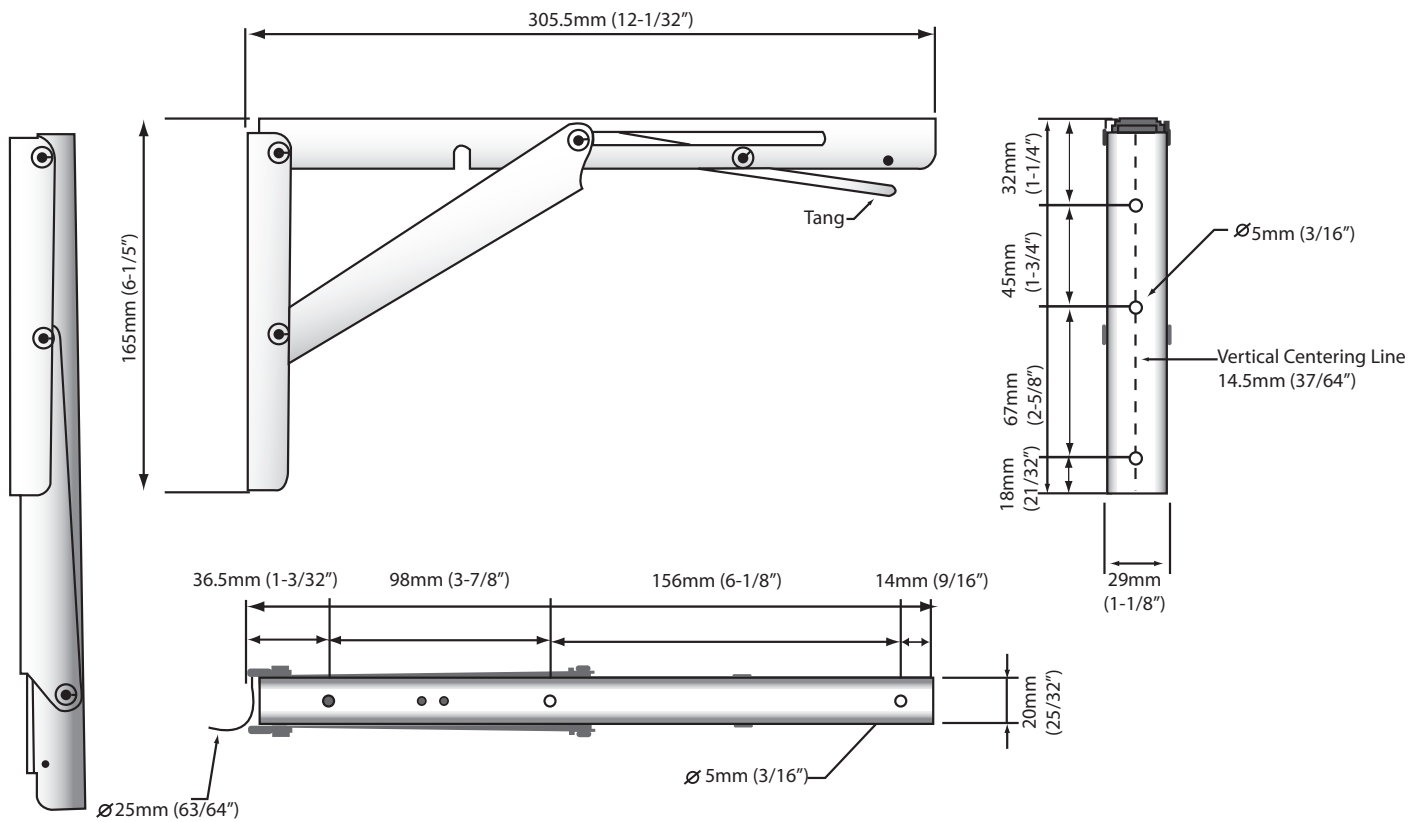
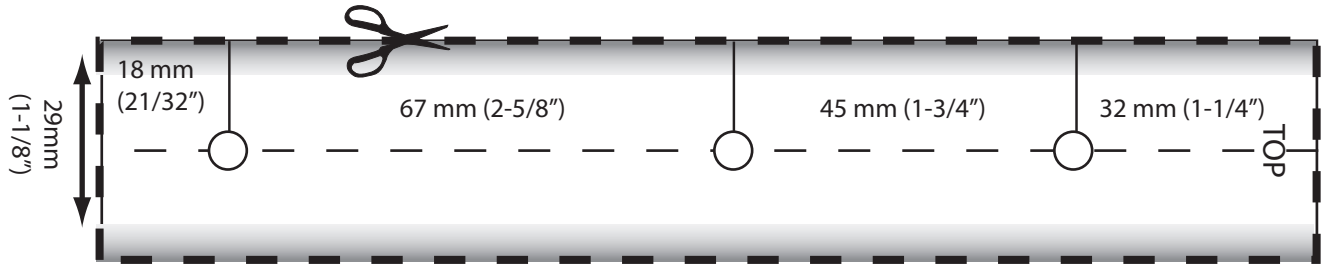

**\*\*Do not use template unless received with original bench instructions. Printing from a home printer may not print to size.**