

LIFETIME LIMITED WARRANTY

Your Proactive branded Two Button Folding Walker is warranted to be free of defects in materials and workmanship for the lifetime of the product for the original purchaser.

The applicable warranty period shall commence from date of shipment to the original purchaser, unless there is an expiration date on the component in which case the warranty shall expire on the earlier of warranty period or the expiration date.

This device was manufactured to the highest standards and carefully inspected prior to shipment. This Lifetime Limited Warranty is a statement of our confidence in the materials and workmanship of our products and our assurance to the consumer of years of reliable service.

This warranty does not cover device failure due to owner misuse or negligence, or normal wear and tear. The warranty does not extend to non-durable components, such as casters, rubber accessories and grips, which are subject to normal wear and require periodic replacement.

If you have a question about your Proactive device or this Lifetime Limited Warranty, please contact an authorized Proactive dealer.



Two Button Folding Walker



*Pictured above in Black Aluminum



*Pictured above in Silver Steel

Model	w/o Wheels	w/Wheels
Junior Aluminum	PM1051AJ	PM1052AJ
Adult Steel	PM1051	PM1052
Adult Aluminum	PM1051A	PM1052A

Owner's Manual

TWO BUTTON FOLDING WALKER DIAGRAM

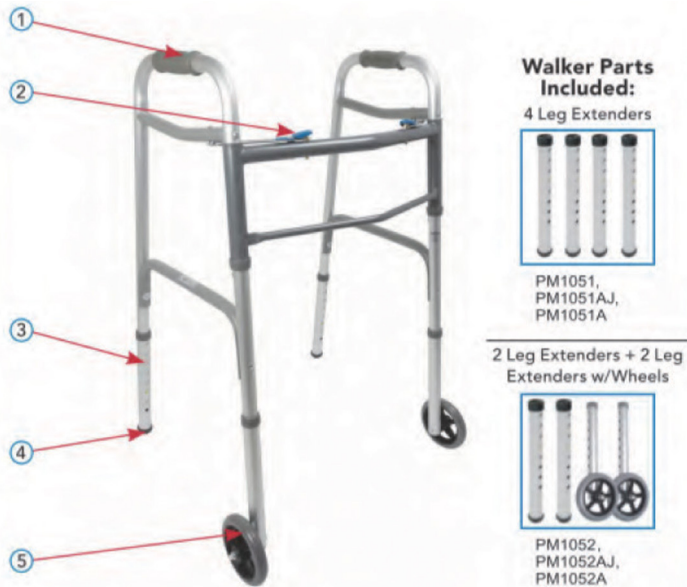

WEIGHT CAPACITY: 350 lb (159 kg)

1. Contoured hand grips
2. Push button folding mechanism
3. Height adjustable legs
4. Glide leg tips
5. Height adjustable front wheels

*The height adjustable front wheels and glide leg tips are included with Item#'s PM1051, PM1052, PM1051A, PM1052A, PM1051AJ, PM1052AJ

WARNINGS

- Maximum weight capacity: 350 lb/159 kg (PM1051, PM1052, PM1051A, PM1052A, PM1051AJ, PM1052AJ)
- Make sure your walker is adjusted to your correct height.
- **DO NOT** stand on walker.
- Inspect all parts for shipping damage before assembly. If there is shipping damage - **DO NOT USE**. Contact dealer/ carrier for further instructions.
- This product should not be used without instruction from a healthcare professional.
- Do not use this walker in pools, showers or other water environments, as this could result in corrosion of parts that result in damage to the walker and possible injury to the user.
- Always avoid unsafe walker conditions, such as soft, slippery or moving surfaces, uneven paths and obstacles.
- Do not exceed the maximum weight capacity intended for this product.
- If you are transferring to or from a wheelchair to use this product, be sure the wheelchair wheels are securely locked.
- This walker is not intended for use on stairs.
- Do not push one side of the walker ahead and then other side without lifting the walker first.
- This walker is **NOT** equipped with rear wheel brakes. **DO NOT** install the optional 5" wheels on the back legs.
- Optional 5" wheels **MUST** be installed on the front legs only, with the wheels facing the outside of the walker.
- Make sure that the brass push buttons on all the parts are fully protruding through the locking holes. This will ensure that all connections are locked in position.
- Check the rubber tips on the height adjustable legs for rips, wear or if they are missing. Immediately replace any or all if any of these imperfections exist.
- Accessories designed by other manufacturers have not been tested by Proactive and are not recommended for use with this product.
- **DO NOT** use the hand grips to fully support the user's body weight.
- Users with limited physical capabilities should be supervised or assisted when using the walker.
- Proactive Medical Products assumes no responsibility for any damage or injury caused by improper installation, assembly or use of this product.

**FAILURE TO FOLLOW THE
ABOVE INSTRUCTIONS MAY RESULT
IN SERIOUS INJURIES.**

FOLDING THE WALKER

This two button walker is designed to fold quickly and easily for transportation and storage.

1. Standing behind the walker, press down and hold the blue button on the right side with your left hand (Fig. G).
2. With your right hand, grab the right side rail and swing it all the way towards the center of the walker (Fig. H).
3. Repeat steps 1 & 2 for the left side of the walker, until completely folded (Fig. I).



MAINTENANCE

- To clean, use a mild soap and water solution, rinse with clean water on a damp cloth, then dry with a soft cloth.
- Ensure that the walker is thoroughly dried before using.
- **NEVER** use organic solvents, abrasive cleaners or scouring pads on any part of the walker.
- Check all the parts and movable connections before each use to ensure that the walker is safe to use. If deemed unsafe, immediately discontinue use and replace any or all parts in question.
- Check the rubber tips on the height adjustable legs for rips, wear or if they are missing. Immediately discontinue use and replace any or all parts if any of these imperfections exist.
- To ensure the best service from your product, always use Proactive replacement parts. Contact your authorized dealer for more information.



WARNINGS

- **DO NOT ATTEMPT TO ADJUST OR OPERATE THIS WALKER WITHOUT READING ALL INSTRUCTIONS CAREFULLY.**

Congratulations on purchasing a quality Proactive Two Button Folding Walker. Our two button walkers are lightweight and conveniently provide stability and balance in your daily activities. Please be sure to read these instructions and warnings thoroughly and follow the instructions of your healthcare provider to maximize the walker's benefits and your safety.

DO NOT ATTEMPT TO ADJUST OR OPERATE THIS WALKER WITHOUT READING ALL INSTRUCTIONS CAREFULLY.

ASSEMBLY INSTRUCTIONS

Remove all packaging including tape, cardboard and plastic before use. Lay out all the pieces and make sure to inspect them prior to assembly. If any parts are missing or damaged, **DO NOT** attempt to assemble the walker. Contact your distributor immediately.

NOTE: DO NOT use excessive force when installing any parts.

1. Hold the folded frame in the upright position (Fig. A).
2. Unfold the two (2) side frame pieces until you hear an audible click from each of the push buttons (Fig. B). Stand the walker in the upright position. Gently push the side frame pieces towards the center to ensure the push buttons have securely locked into place.

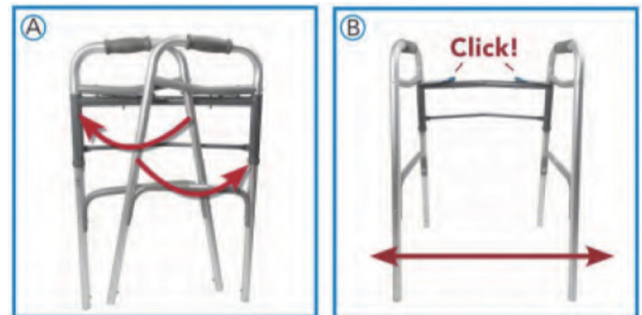

TWO BUTTON WALKER - WITHOUT WHEELS

NOTE: If you have purchased a two button walker with 5" wheels, please skip to the next section.

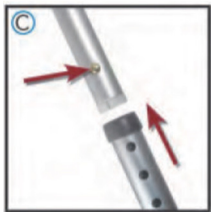

1. Insert one (1) leg into the end of one of the side frame pieces (Fig. C).
2. Insert the leg by depressing the brass push pin and sliding the leg until it is securely in place. When the leg is securely in place, the brass push pin will click into place and extend out of the locking hole.
3. Repeat this step for the remaining three (3) legs.

TWO BUTTON WALKER - WITH 5" WHEELS

NOTE: If you have purchased a two button walker without wheels, please read the previous section.



1. When installing the wheel legs on your two button walker, you must make sure they are installed on the front two legs and the wheels are facing outward (Fig. D).
2. Insert one (1) leg tip into the end of one of the back legs of the side frame (Fig. E). Insert the leg tip by depressing the brass push pin and sliding it until it is securely in place. When the leg tip is securely in place, the brass push pin will audibly click into place and extend out of the locking hole. Repeat this step for the other leg tip.

3. Insert one (1) wheel leg into the end of one of the front legs of the side frame (Fig. E). Insert the wheel leg by depressing the brass push pin and sliding it until it is securely in place. When the wheel leg is securely in place, the brass push pin will audibly click into place and extend out of the locking hole. Repeat this step for the other wheel leg.
4. Make sure the two (2) front wheels are on the outside of the walker (Fig. D).

ADJUSTING THE HEIGHT

Before this two button walker can be used, the handle height will need to be adjusted to the user's specific needs. Once the walker has been opened, legs are installed and the sides have been confirmed as locked into place, stand with the middle of your feet even with the walker's back legs.

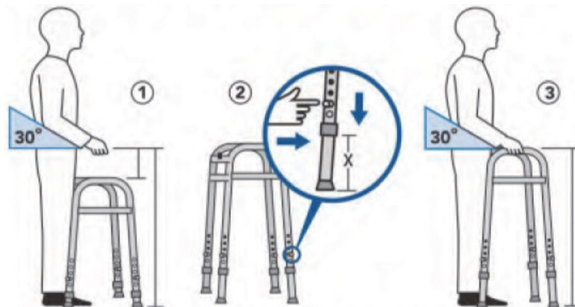

1. With arms relaxed at your side, the handle of the walker should be at wrist height, or with your hands on the hand-grips, your arms should be flexed 20"-30".
2. Depress the brass push pins and slide each leg until the desired height is reached. Once the desired height has been reached, lock the leg securely in place by sliding the leg until the brass push pin clicks into place and extends out of the locking hole. Repeat this step for the other 3 legs. The lock holes have been numbered to ensure all four legs match the same height.
3. To be sure the legs are securely locked into place, gently push down on the hand grips or pull on each of the legs.

CAUTION: Ensure that all four walker legs are adjusted to the same height and that **ALL** brass push pins are extended through the locking holes before use.

WALKING WITH THE WALKER

1. Start with the middle of your feet even with the walker's back legs.
2. Holding on to the hand grips, pick the walker up and place it in front of you at an arms length that feels comfortable. Be sure all four legs return to the floor.
3. Carefully step forward with your weaker leg into the middle of your walker followed by your stronger leg. This will help keep weight off your weaker leg by using your arms for added support.