

SERVICE MANUAL

**Outdoor rollator Let's Go Out
from TrustCare**

TABLE OF CONTENTS

Exchange of brake wire	page 3
Exchange of wire adjustment screw	page 7
Exchange of front wheel swivel with screw	page 8
Exchange of front wheel swivel without screw	page 9
Unfold hook adjustments	page 10
Exchange of linkage arm for folding	page 11
Parking brake adjustments	page 12
Mounting the middle joint of the folding cross	page 13

Exchange of brake wire.

Year of manufacturing 2012.

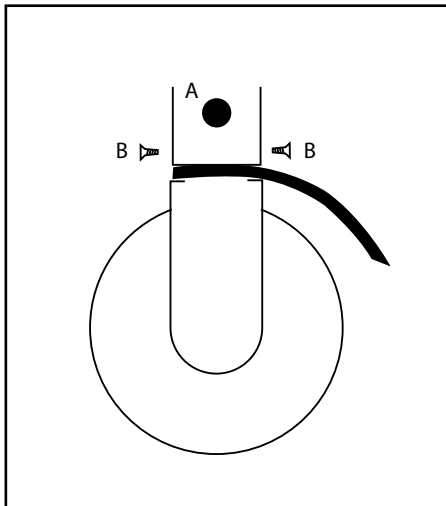

1. For disassembling the brake mechanism, unscrew the double screw A and the two screws holding the fender.

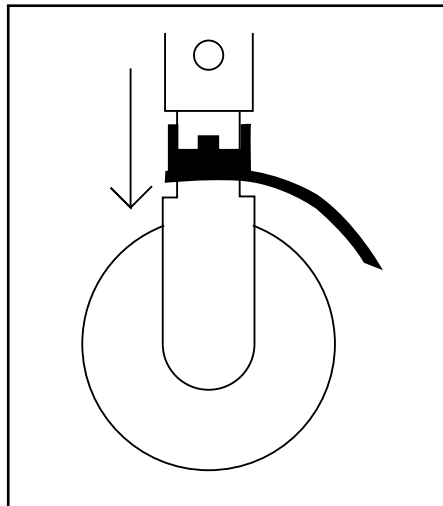

2. Pull out the rear wheel, the fender and the mounting plate with the brake mechanism.

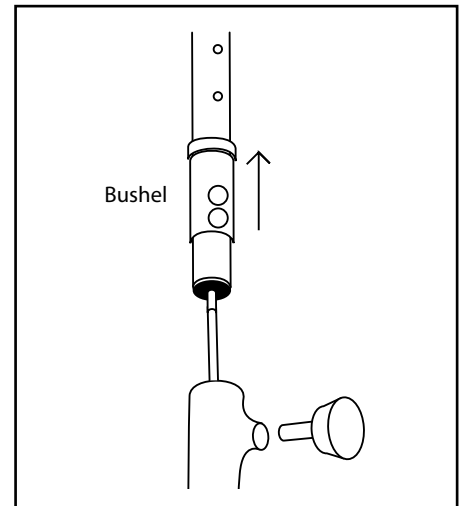

3. First completely unscrew the adjustment knob to release the bushel. Then pull up the handle tube entirely from the front leg tube until the wire is stretched.

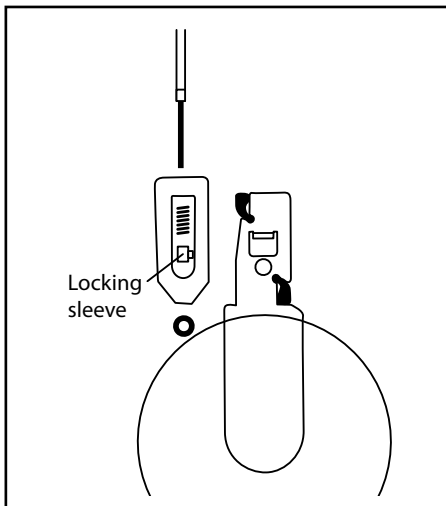

4. Unscrew the locking sleeve at the bottom end of the wire and disassemble the brake mechanism..

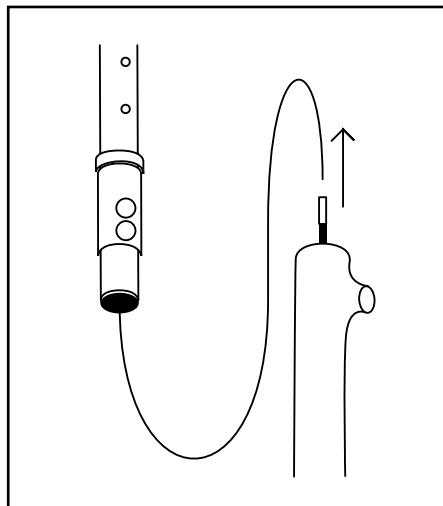

5. Pull out the wire completely but leave the sleeve in the tube which makes it easier to insert the new wire..

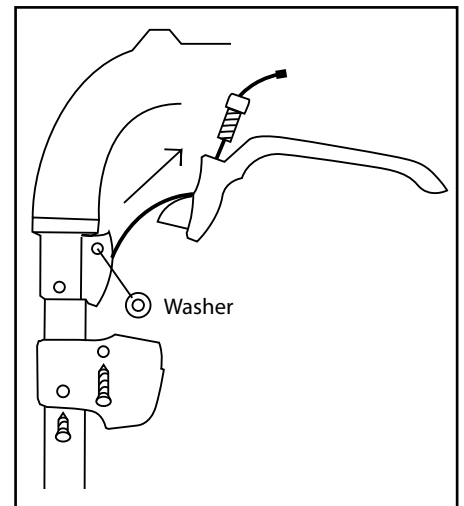

6. Unscrew the two black screws and pull down the brake housing so the brake lever can be removed. Then remove the wire completely.

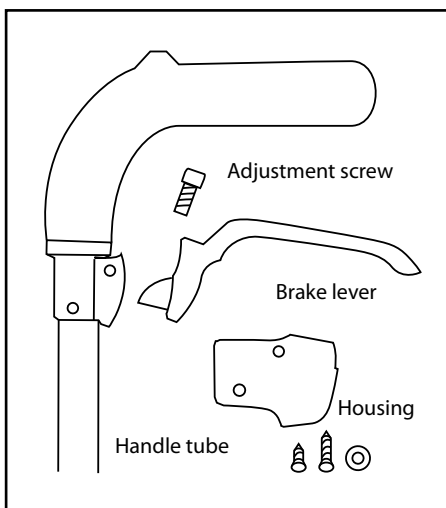

7. Damaged parts such as handle tube, brake lever, adjustment screw, or brake housing can be exchanged if needed.

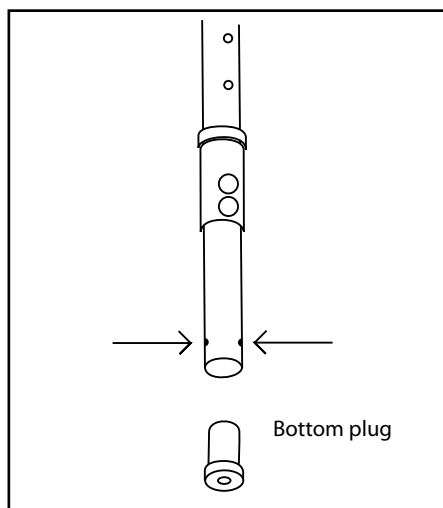

8. To remove the bottom plug, press both snaplocks on either side of the tube.

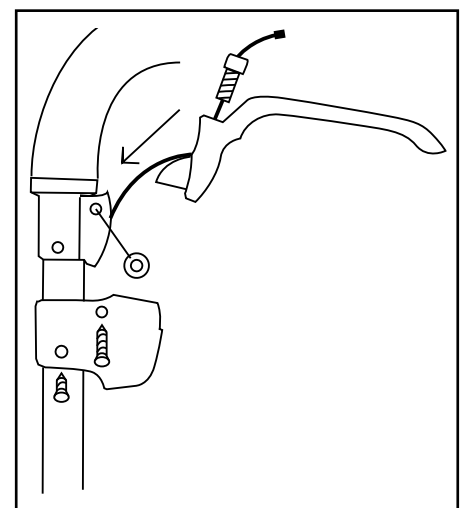

9. Insert the new wire through the screw, brake lever, and handle tube. Screw back the brake housing.

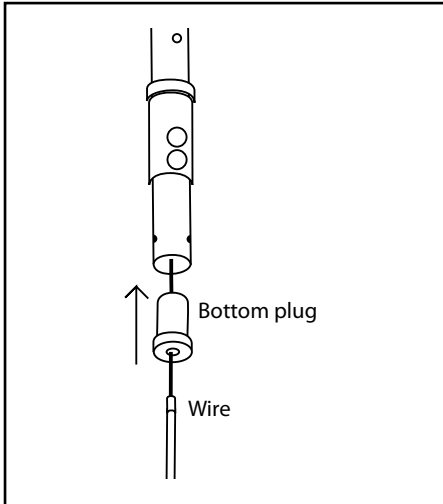

10. Put the bottom plug on the wire and press it into the handle tube. Add the sleeve to the wire.

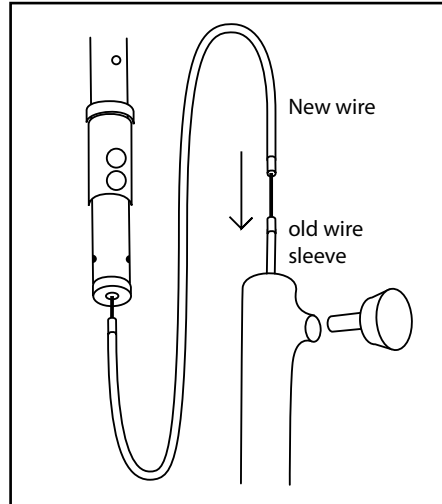

11. Put the end of the wire into the older wire sleeve and use this as a guide to lead the new wire into the rear leg.

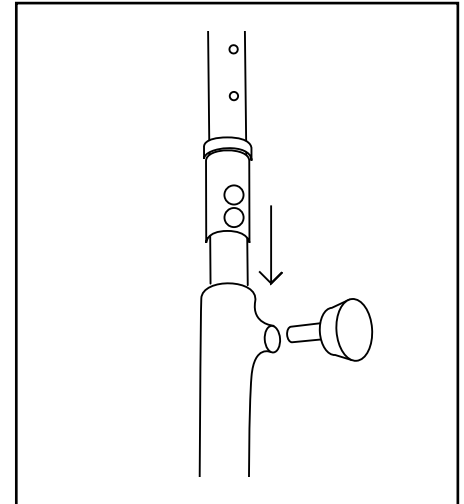

12. Push the handle tube down to the bottom and screw the height adjustment knob back in place.

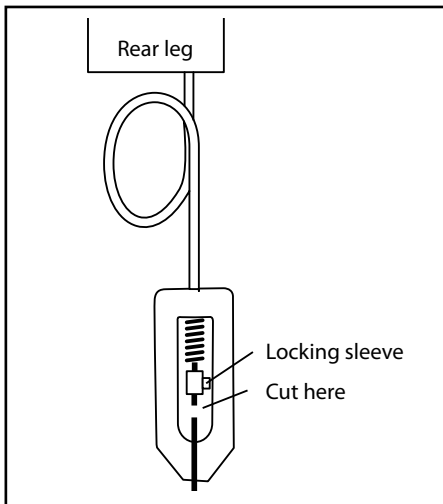

13. Mount the yoke, spring and locking sleeve. Check the function of the brake when the wire has a loop, see picture. Then cut the protruding part of the wire.

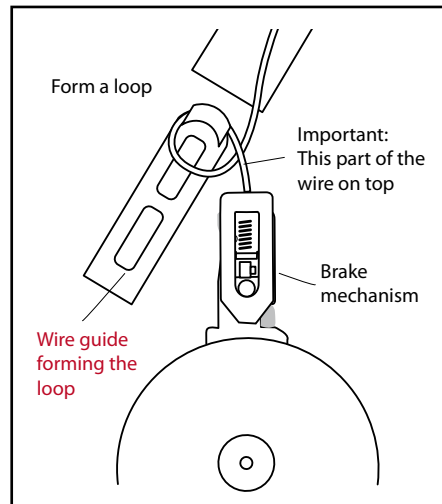

14. Use the wire guide to form a loop inside the rear leg. Make sure that the wire is not pinched when it is inserted into the rear leg.

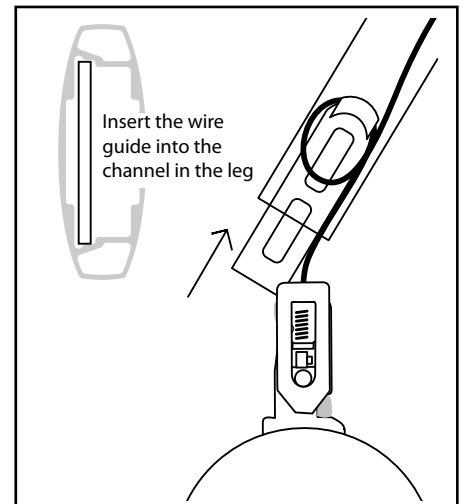

15. Push the wire guide entirely into the rear leg. Then push in the mounting plate for the rear wheel into the same channel in the rear leg profile.

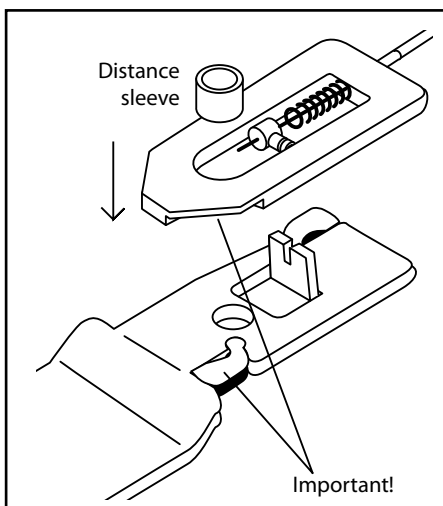

16. Before putting in the mounting plate, make sure that the cavities in the yoke correspond to the rubber parts.

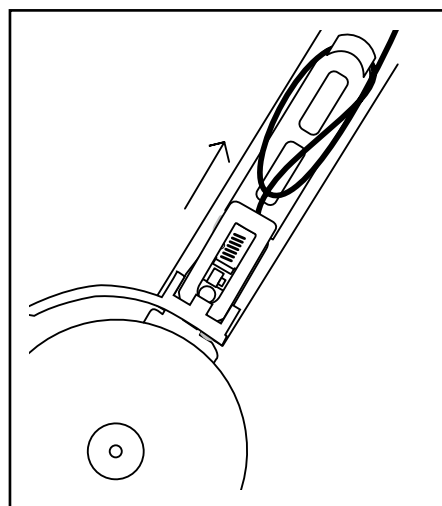

17. Make sure that the distance sleeve is included when the mounting plate is pushed in. Then add the fender.

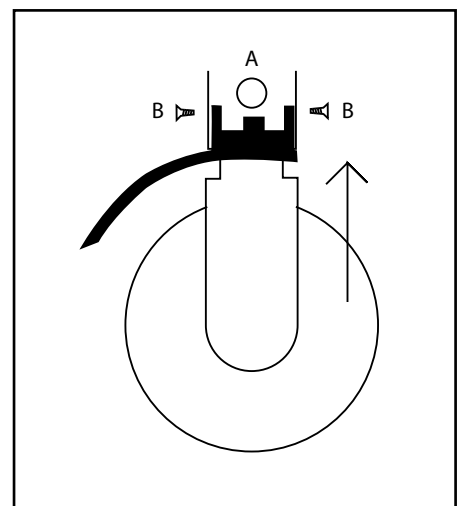

18. Screw the black double screw back in place and fix the two screws that hold the fender.

Exchange of brake wire.

Year of manufacturing from 2013 onward.

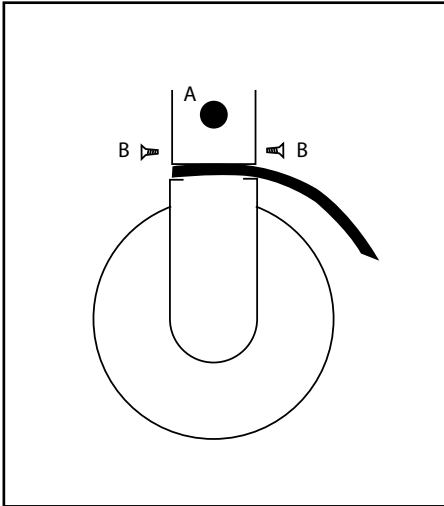

1. For disassembling the brake mechanism, unscrew the double screw A and the two screws holding the fender.

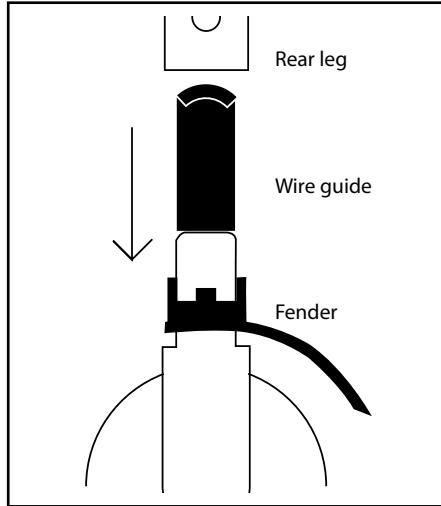

2. Pull out the rear wheel, fender, and mounting plate with the brake mechanism, and the plastic wire guide inside the rear leg.

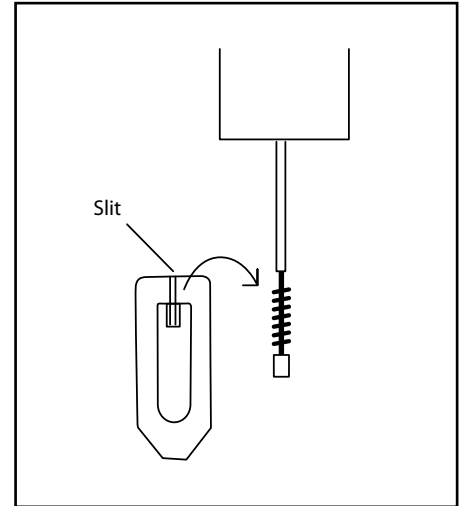

3. Take off the brake yoke from the wire.

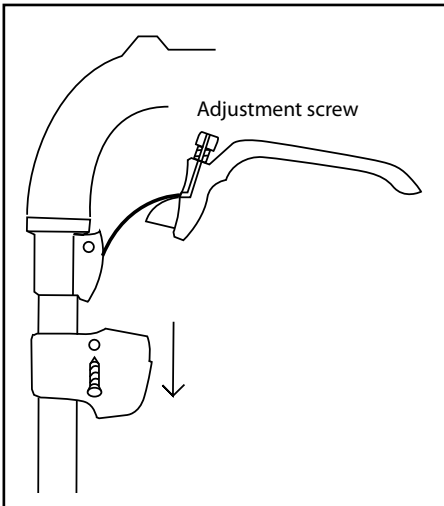

4. Unscrew the height adjustment knob and move the handle tube a little upward. Unscrew the housing around the brake with the screw on the side.

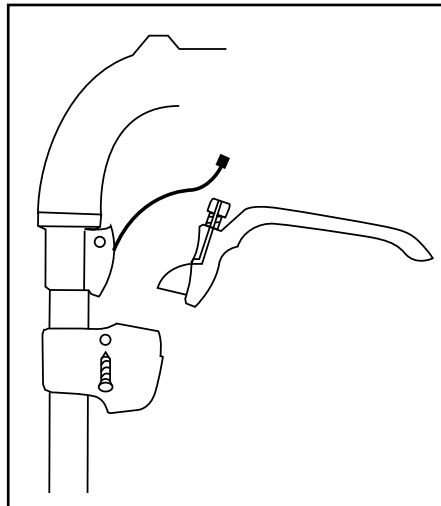

5. Take out the end of the wire from the lever and the screw through the side slits.

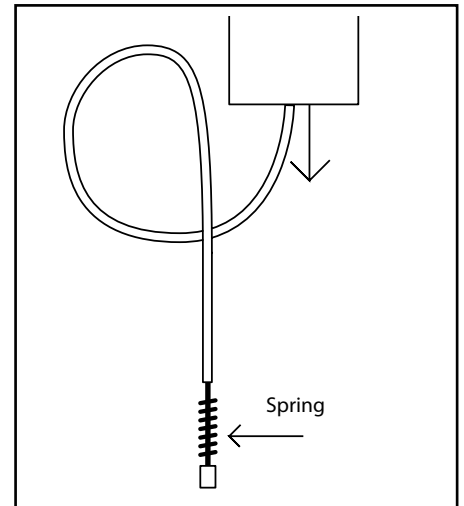

6. Pull out the wire entirely through the rear leg. Keep the spring and use it on the new wire.

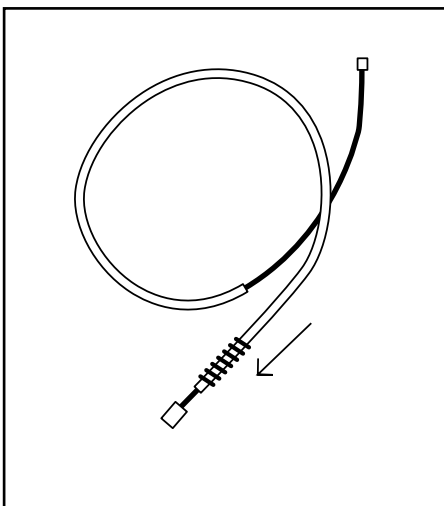

7. Thread the spring over the upper end of the wire and move it down to the bottom.

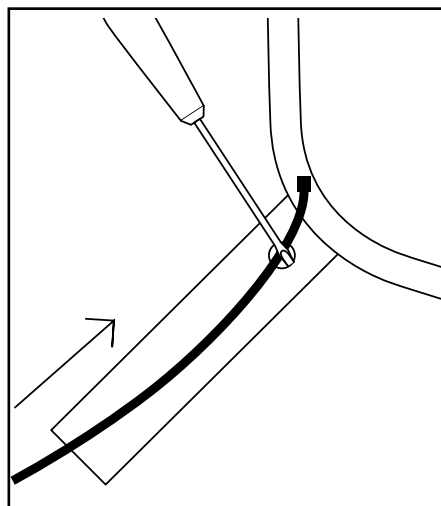

8. Push the upper end of the wire into the rear leg. Use a screwdriver as help to guide the wire into the upper tube.

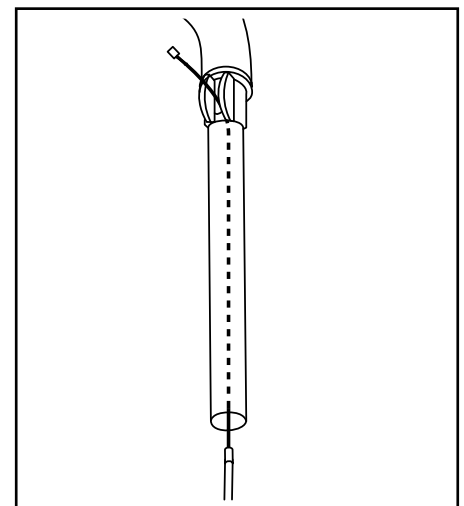

9. Pull out the wire in the upper end and put it into the handle tube all the way up to the hole for the brake mechanism.

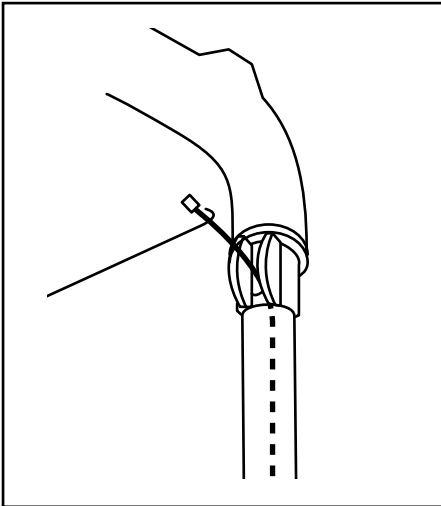

10. Use a bent steel wire to pull the end of the brake wire out through the hole.

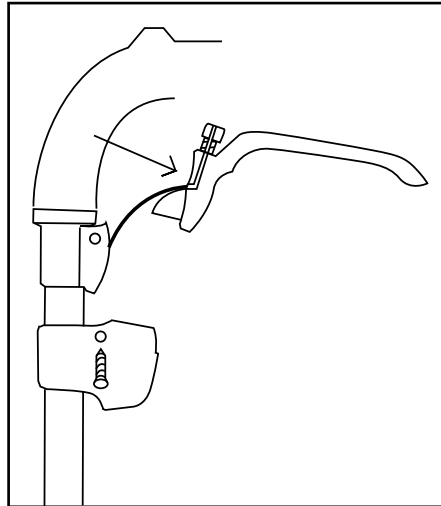

11. Put the wire into the brake lever and the screw through the side slits. Exchange any damaged details before assembly.

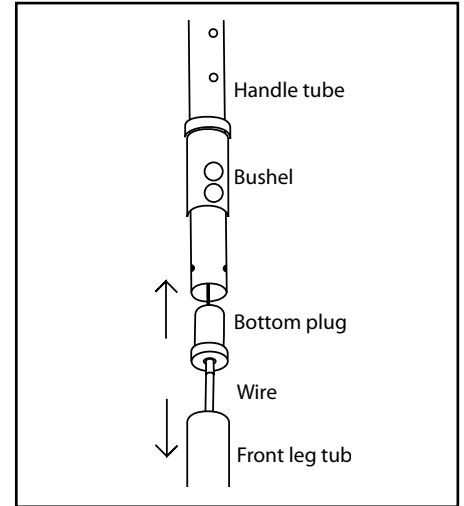

12. Skruva på kåpan, montera bottenpluggen i røret och skjut ner handtagsrøret i frambensrøret hela vagen ner.

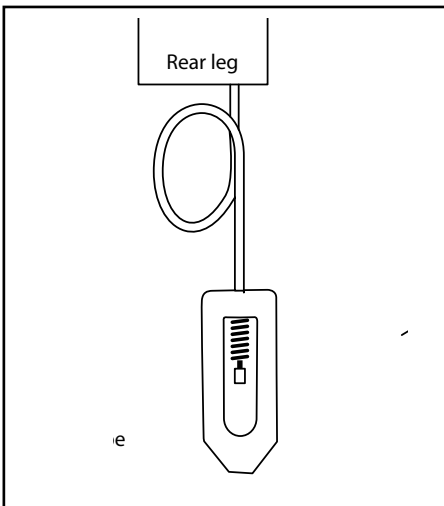

13. Mount the yoke and the spring on the wire. Check the function of the brake when the wire has a loop, see picture.

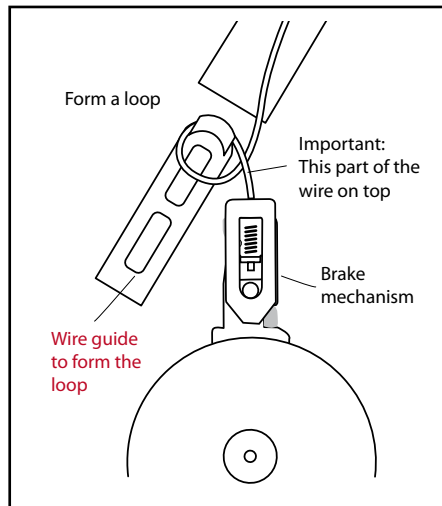

14. Use the wire guide to form a loop inside the rear leg. Make sure that the wire is not pinched when it is inserted into the rear leg.

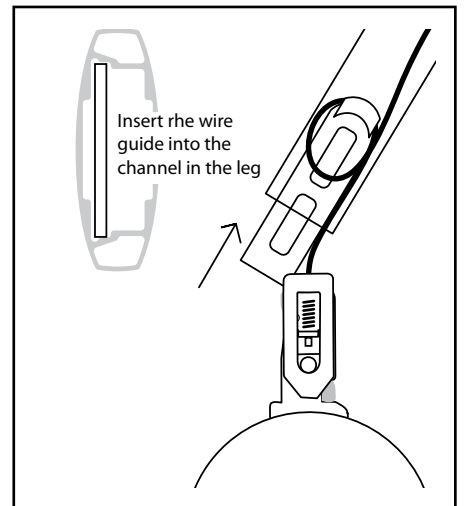

15. Push the wire guide entirely into the rear leg. Then push in the mounting plate for the rear wheel into the same channel in the rear leg profile.

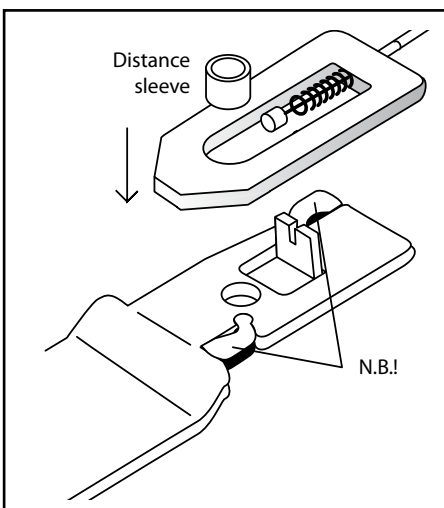

16. Before the mounting plate is pushed in, put the distance sleeve into the yoke. Check that the rubber parts are included.

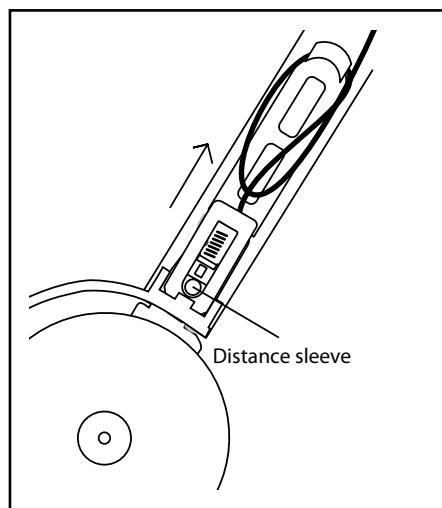

17. Make sure that the distance sleeve is inside the yoke and that the rubber parts don't fall off. Put the fender in place.

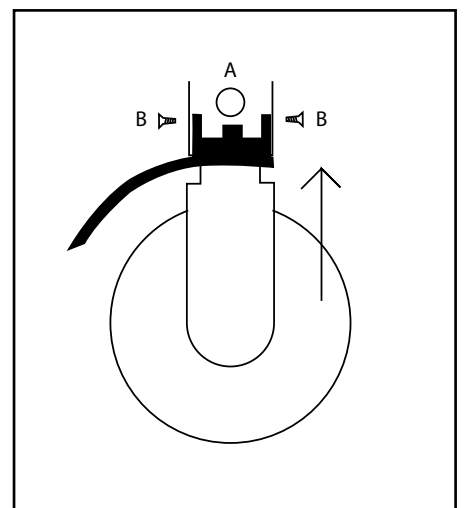

18. Screw back the black double screw A and the two screws B that hold the fender.

Exchange of wire adjustment screw (whole or damaged)

Year of manufacturing from 2013 onward.

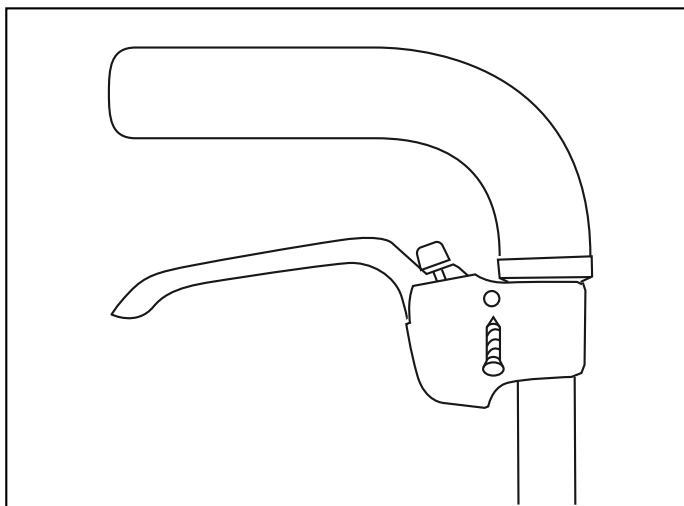

1. Unscrew the screw that holds the black brake housing.

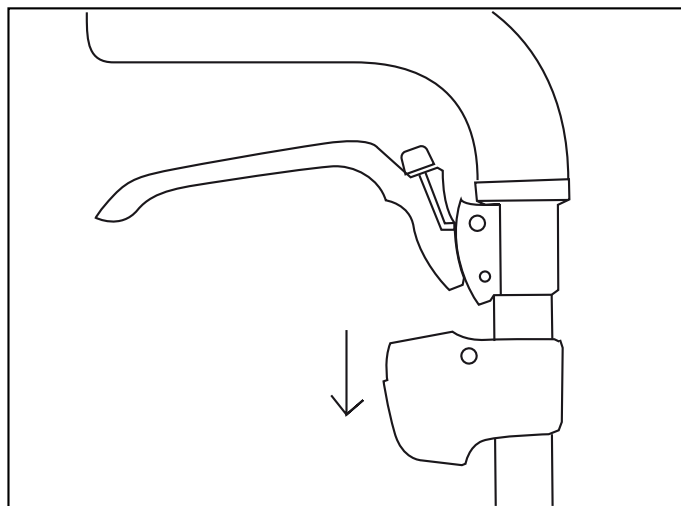

2. Push the brake housing down.

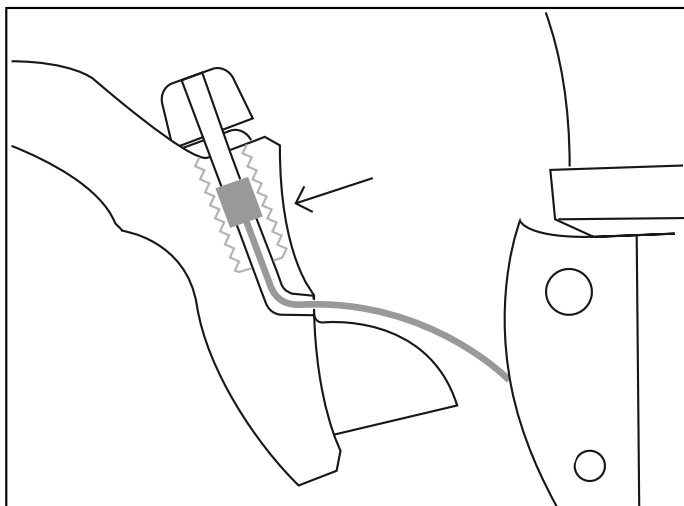

3. To take out the wire, make sure that the slits in the screw and the brake lever correspond. If the screw is broken, use a small screwdriver to turn it to the correct position.

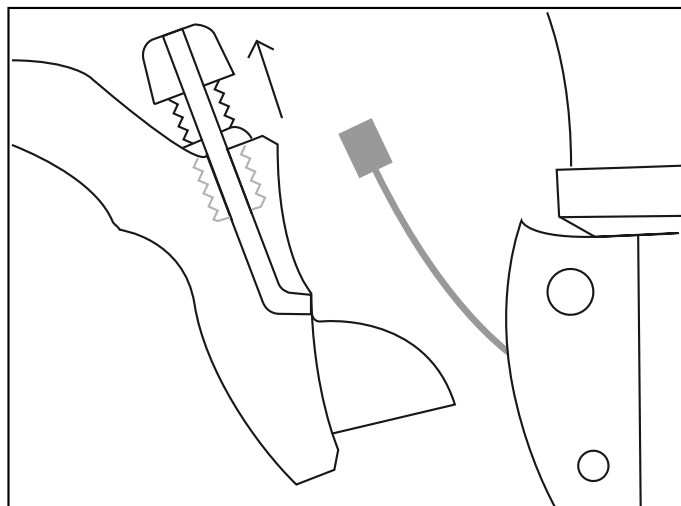

4. The wire can now be taken out and the screw removed. Use the screwdriver if the screw is broken.

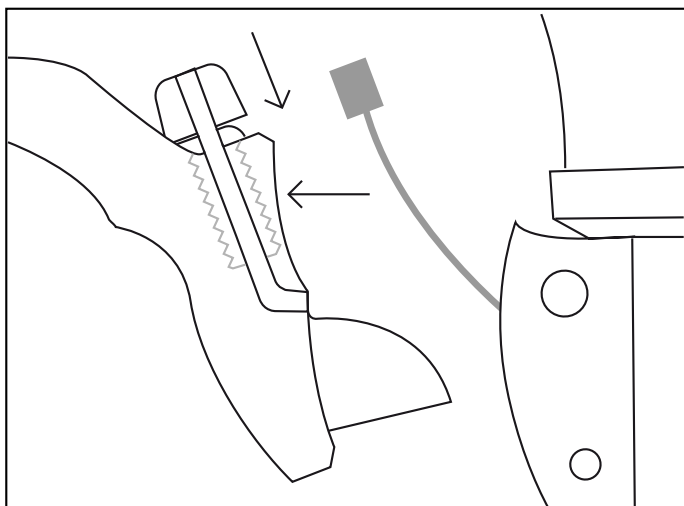

5. Screw the new screw down to the bottom. Make sure the slits correspond and put back the wire.

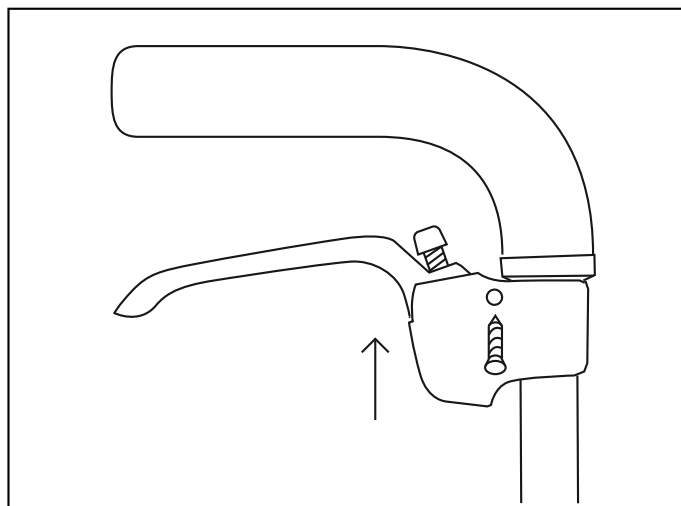

6. Push back the brake housing and screw it in place. Adjust the wire tension with the new screw.

Exchange of front wheel swivel with screw fixture.

Year of manufacturing 2012.

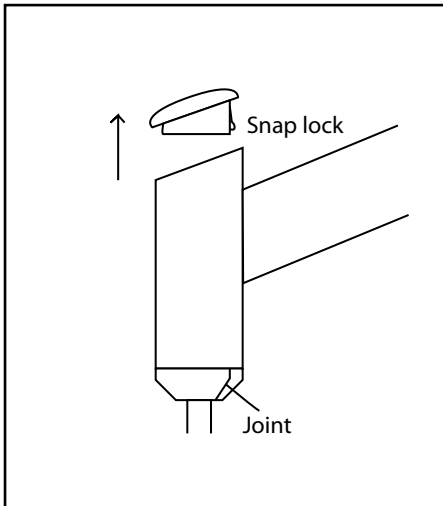

1. Remove the black plastic cap over the front swivel bearing

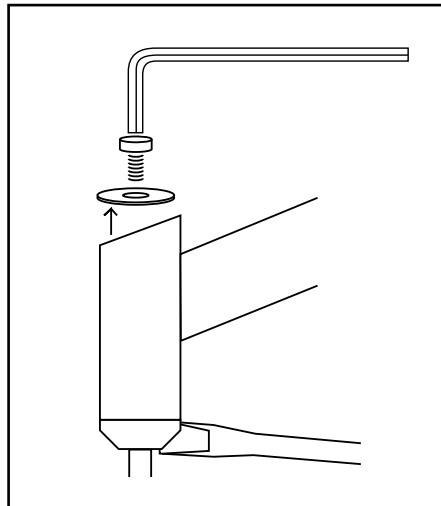

2. Unscrew the screw with an Allen key. Put a screwdriver into the joint in the plastic if the bearing rotates.

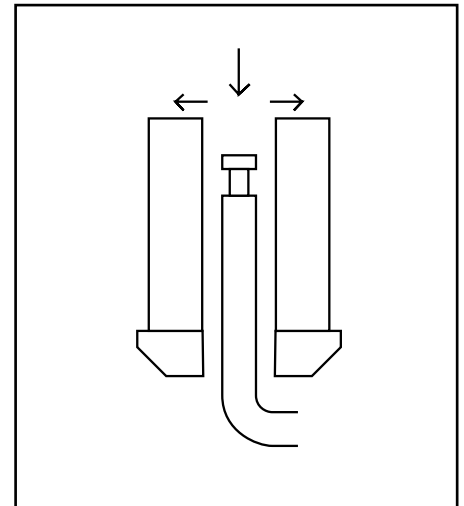

3. Pull out the front swivel and remove the existing bearing.

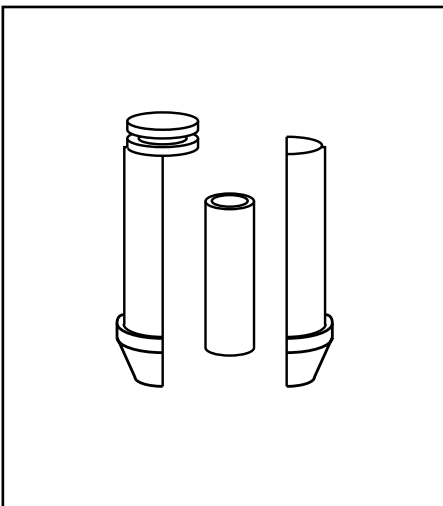

4. The new bearing is in three parts. One plastic part with screw fixture, one shorter plastic part, one brass sleeve.

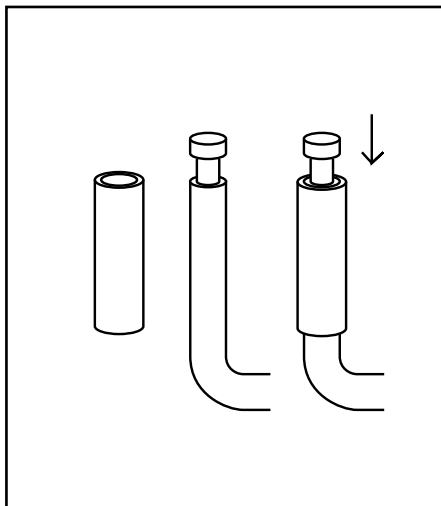

5. Put the sleeve in the top of the front swivel. Put some grease between the sleeve and the swivel.

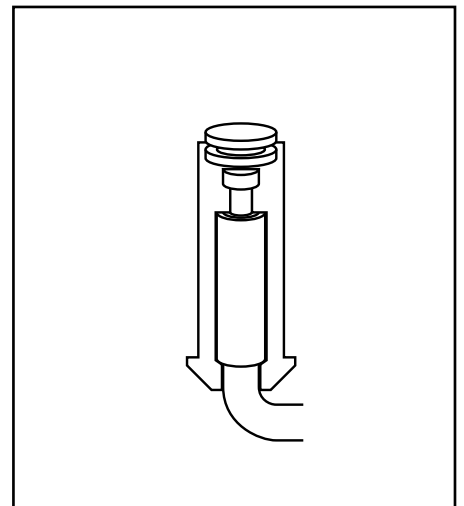

6. Put the two halves together. Make sure that the top of the swivel is locked inside the bearing and will not fall out.

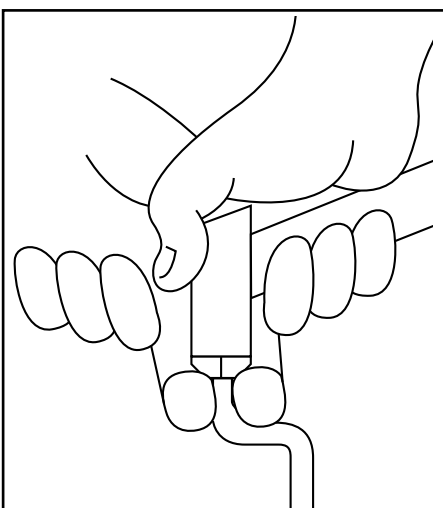

7. Press the new bearing into the tube. Bump against the floor if needed.

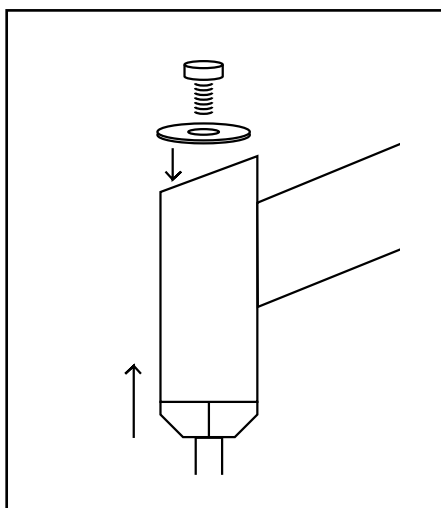

8. Mount the washer and the screw. Tighten the screw securely.

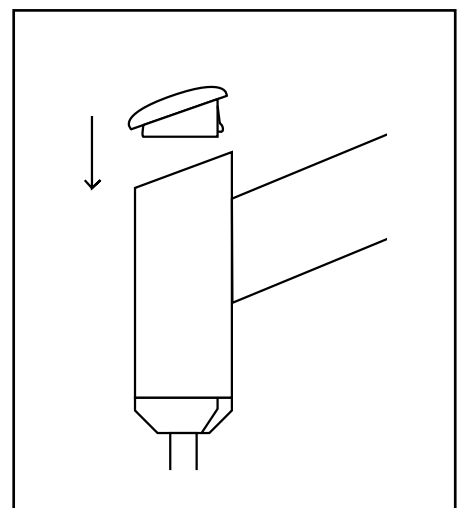

9. Put on the black plastic cap. If necessary fix it with some glue.

Exchange of front wheel swivel without screw fixture.

Year of manufacturing from 2013 onward.

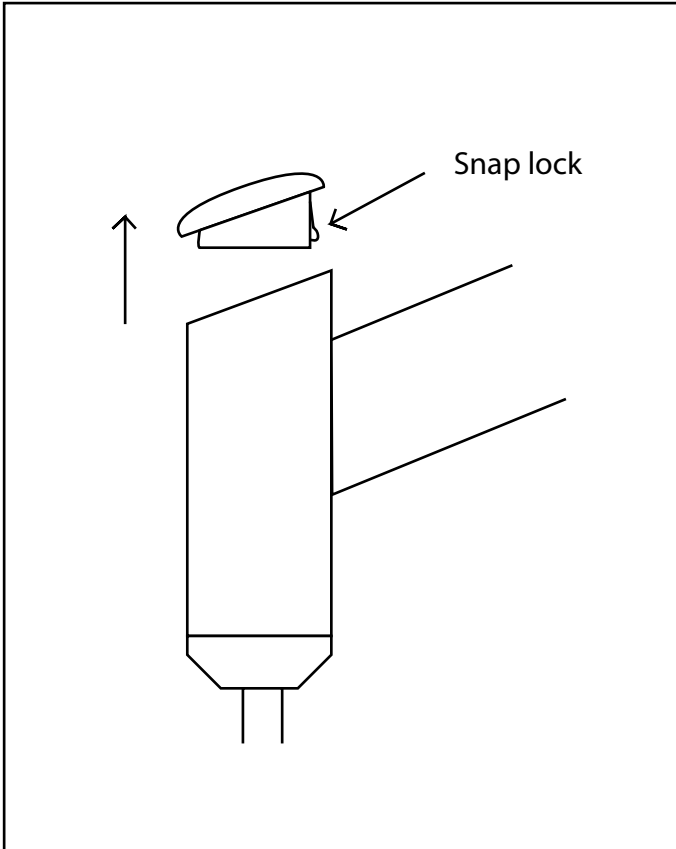

1. Remove the plastic cap above the front wheel bearing.

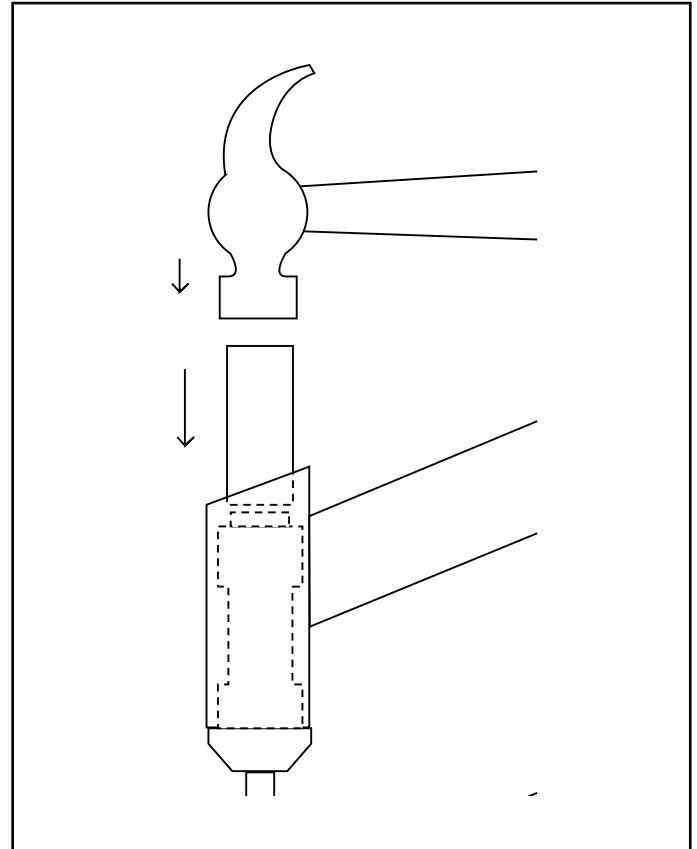

2. Knock the existing bearing out of the tube with a hammer. Use a piece of metal between the hammer and bearing.

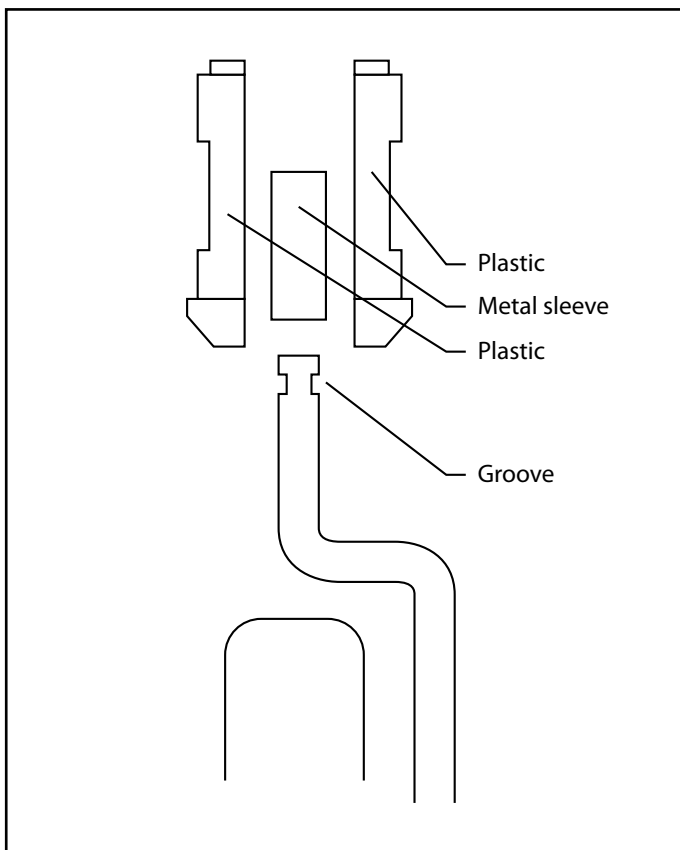

3. Mount the new bearing. Put the metal sleeve on the swivel and add some grease inbetween. Put the two plastic halves together. Make sure that the groove locks the swivel inside.

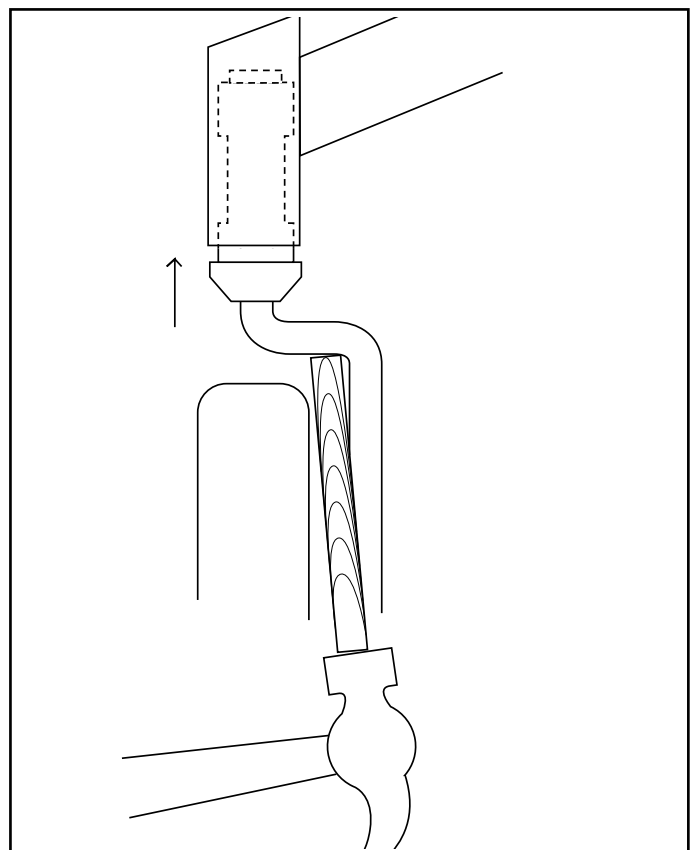

4. Press the new bearing into the tube. Use a piece of wood inbetween and knock it in with a hammer all the way up. Put back the plastic cap.

Unfold hook adjustments.

Year of manufacturing 2012.

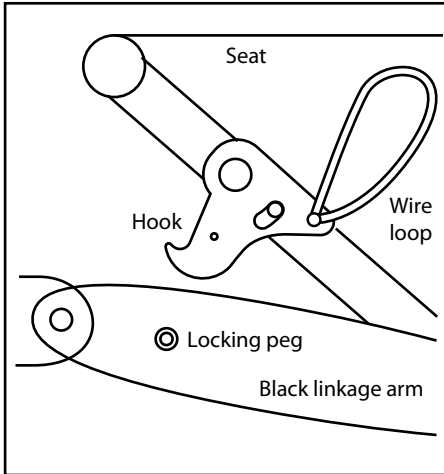

1. Below the seat of the rollator there is a metal hook and a locking peg inside the black linkage arm. The locking peg is a spring dowel pin with a brass sleeve.

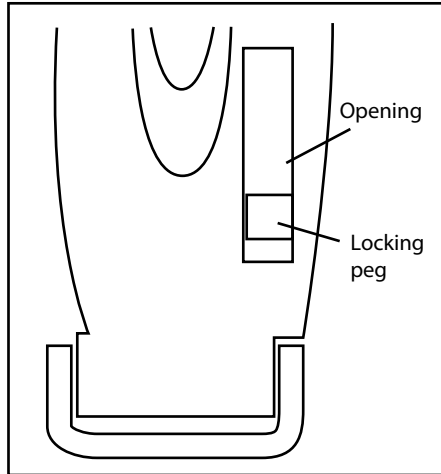

2. First make sure that the locking peg is not damaged or missing. If it is missing it must be replaced.

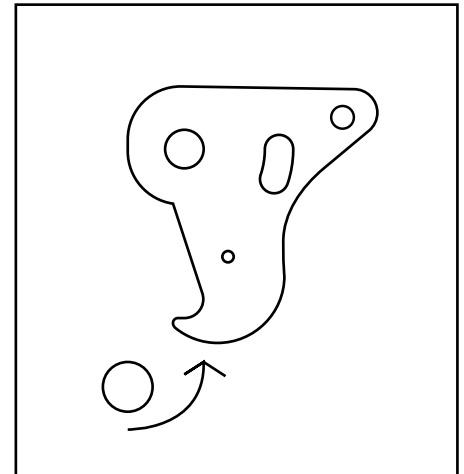

3. If the hook is not locking around the peg and releases involuntarily although the peg is intact it is because the hook is damaged and has an incorrect shape.

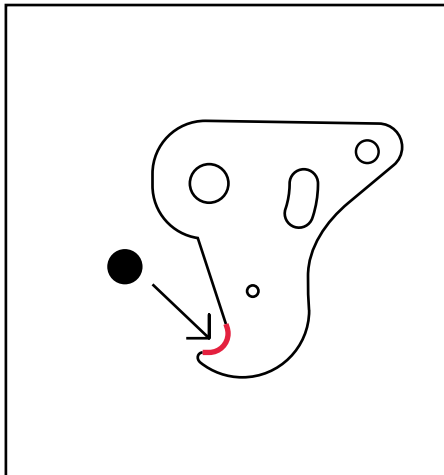

4. File carefully with a small round file to make the tip of the hook deeper. Take it little by little and test the function.

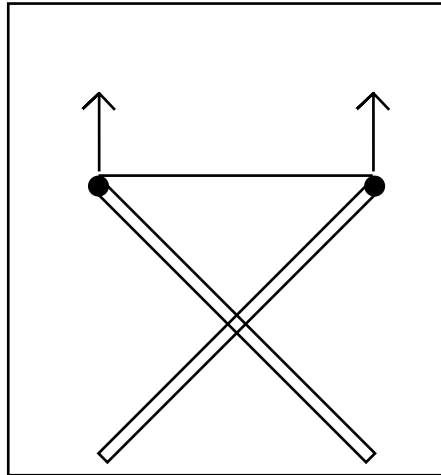

5. Test by lifting the rollator in the two metal tubes that holds the seat. The hook should not release. When the seat is lifted in the hole the hook should release.

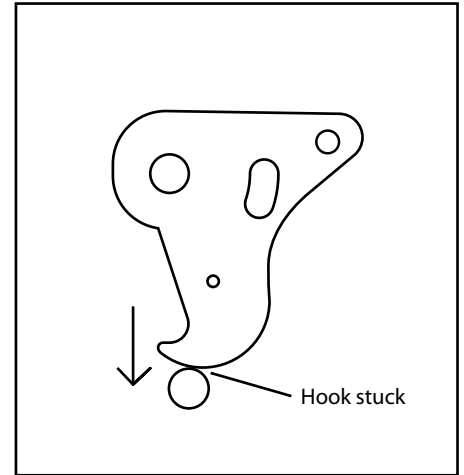

6. If the hook does not pass the peg when the ends of the seat are pressed down the hook will never lock around the peg. The rollator will not unfold correctly.

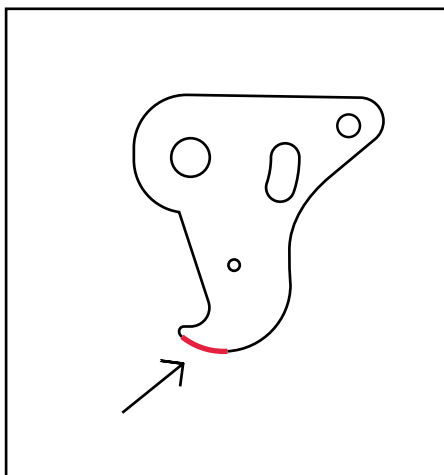

7. File carefully on the bottom side of the hook to give it a shape that allows it to pass the peg. Take it little by little and test the function.

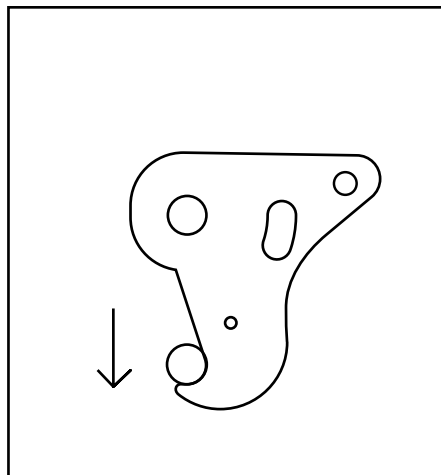

8. When the ends of the seat are pressed down the hook should pass the locking peg and lock safely.

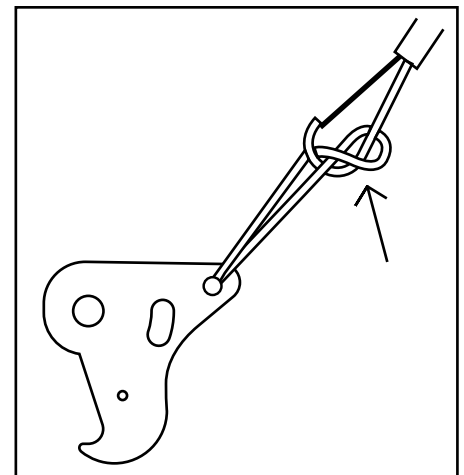

9. The wire that releases the hook when the seat is lifted in the middle hole must have a double loop to function correctly.

Exchange of the linkage arm for folding.

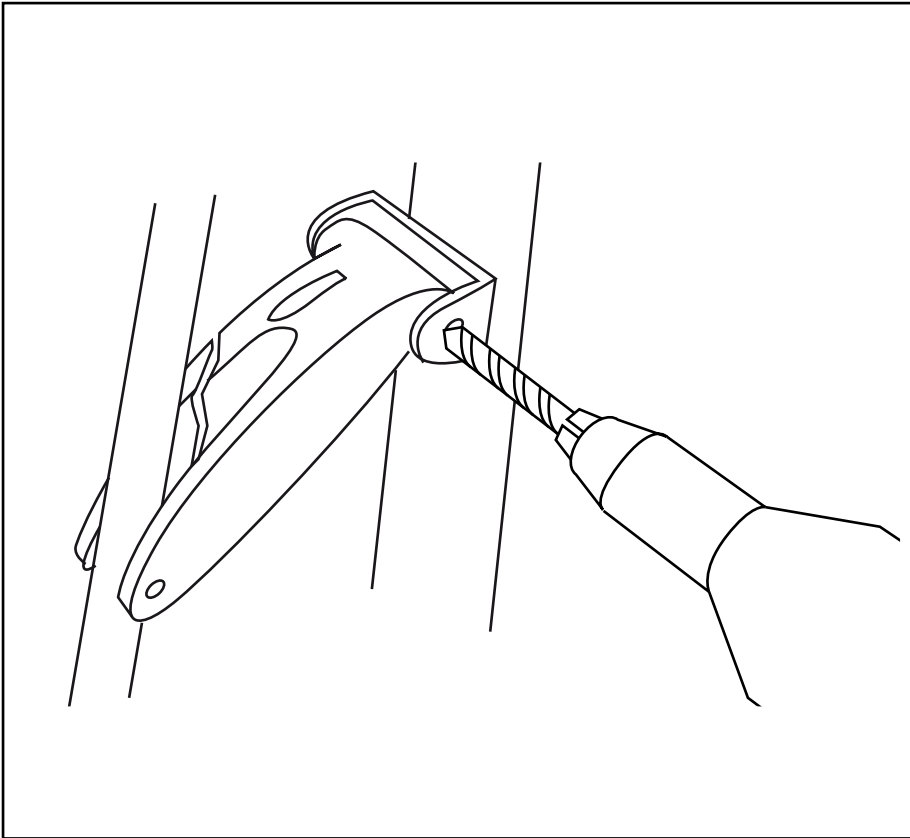

1. Drill out the rivets that hold the plastic linkage arm to the metal frame of the rollator.

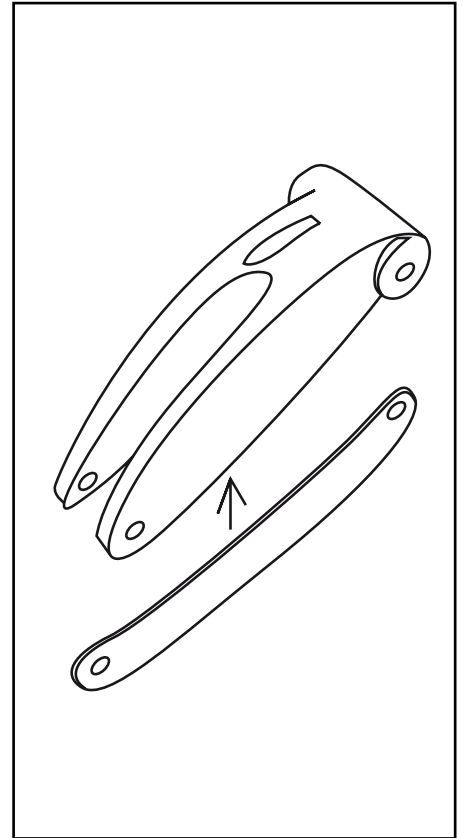

2. Remove the plastic part. Keep the metal reinforcement bar that is inside.

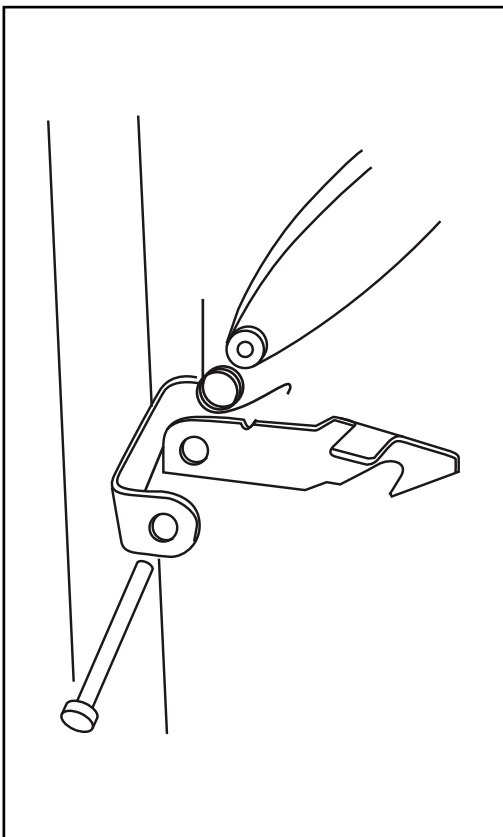

3. Mount the new plastic arm with the metal reinforcement bar. On the left side the hook for folding should also be mounted.

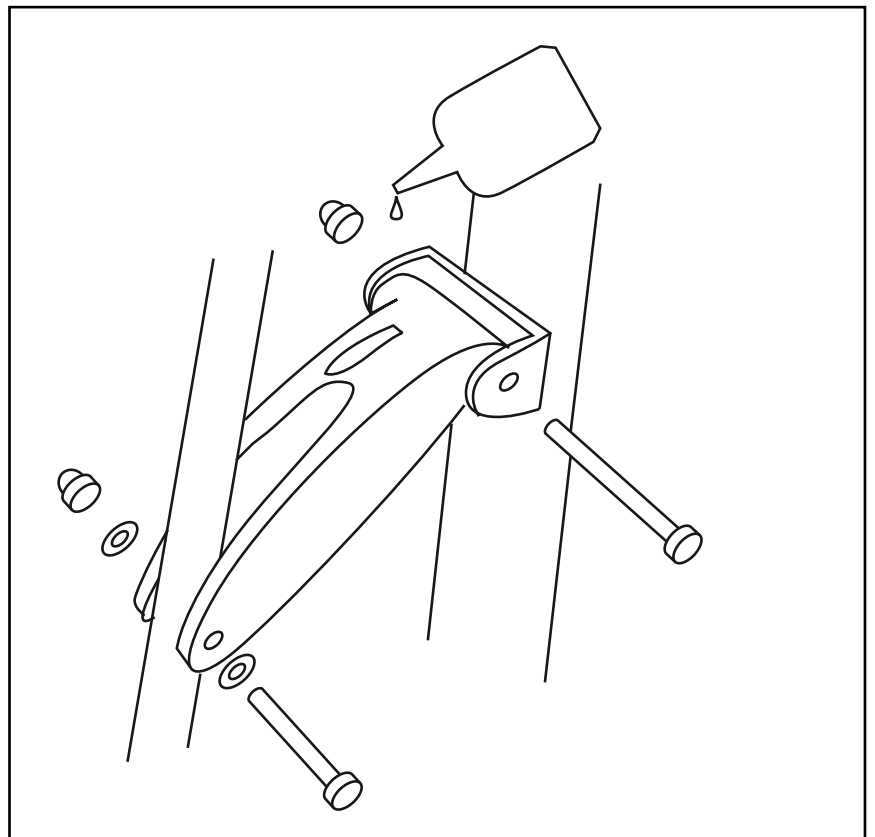

4. Mount the parts using screws, washers, and nuts. Add a drop of Loctite to fix the nuts.

Parking brake adjustments.

Year of manufacturing 2012.

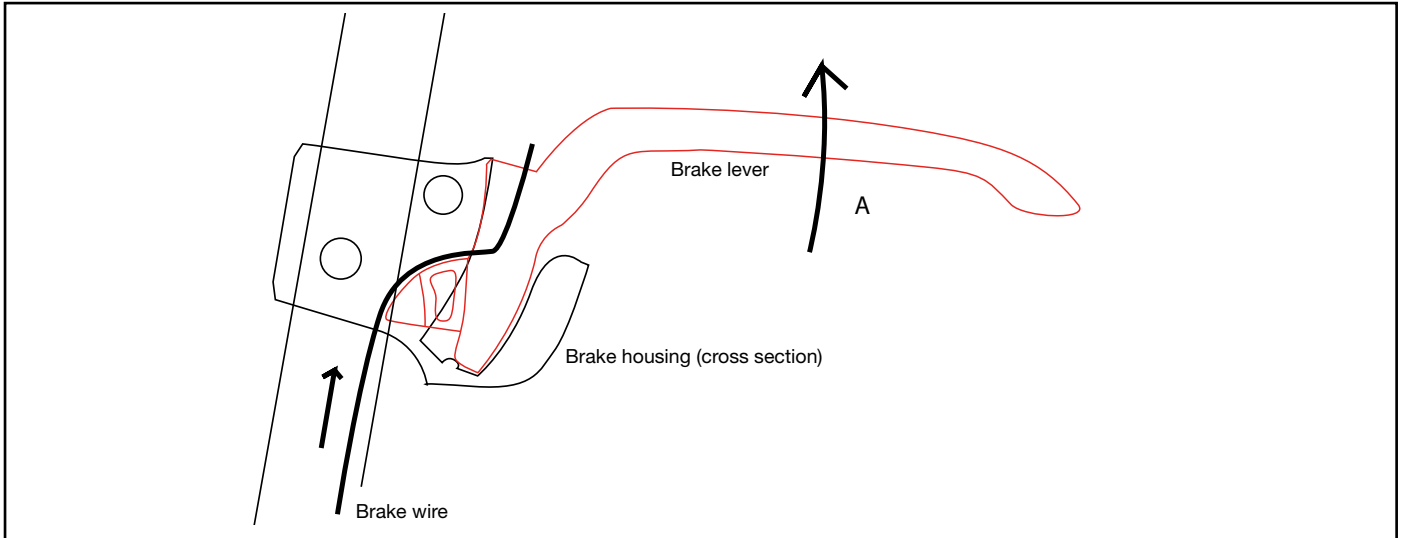

1. This is the function of the brake system on Let's Go Out. When the brake lever is pulled up (A) the wire is stretched and the rollator brakes. The parking brake is activated by pushing the lever down so it will lock in lowest position.

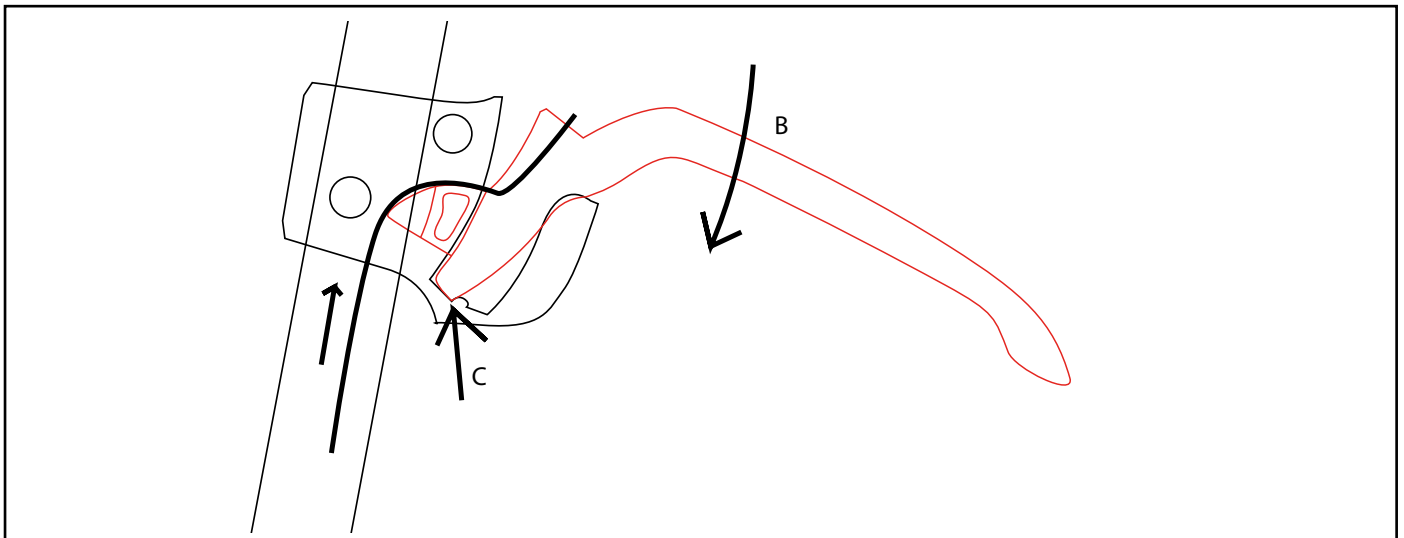

2. When the lever is pushed down the wire is stretched. The bottom end of the lever falls down into the cavity (C) and locks.

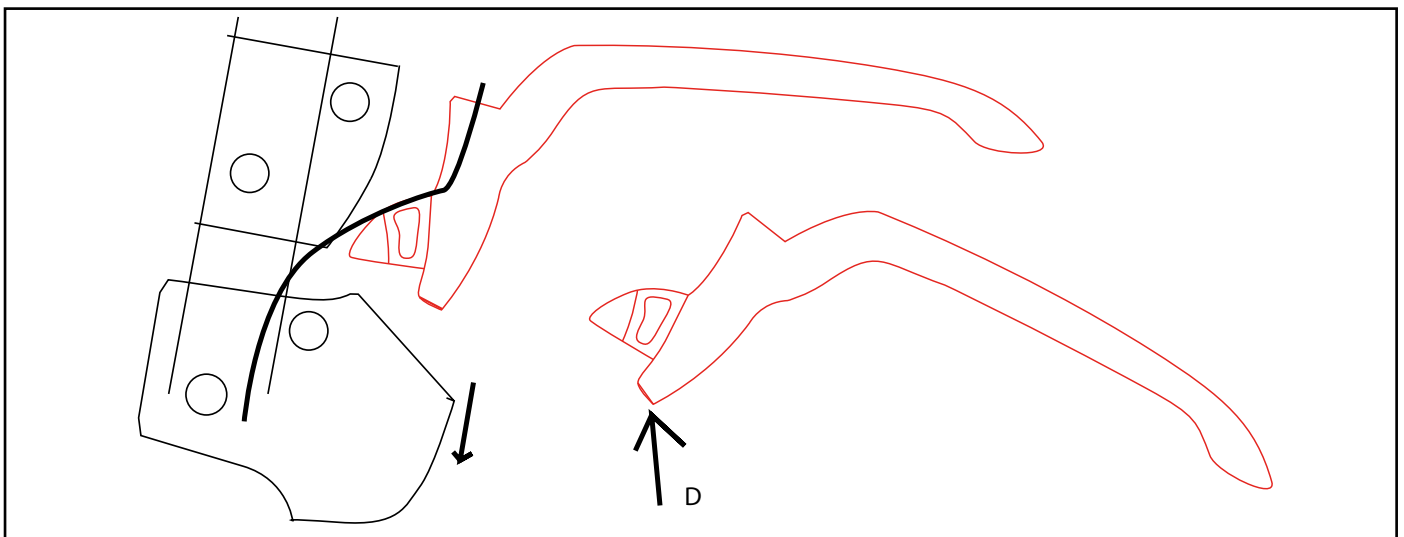

3. If the lever does not lock in the cavity, remove the two screws in the brake housing and push the housing down. Behind one of the screws there is a washer, don't lose it. File the corner at (D) to make it sharper so it will lock better in the cavity. If the brake lever still does not lock, there could be a damage inside the brake housing and it must be replaced.

Mounting the middle joint of the folding cross.

Year of manufacturing 2012.

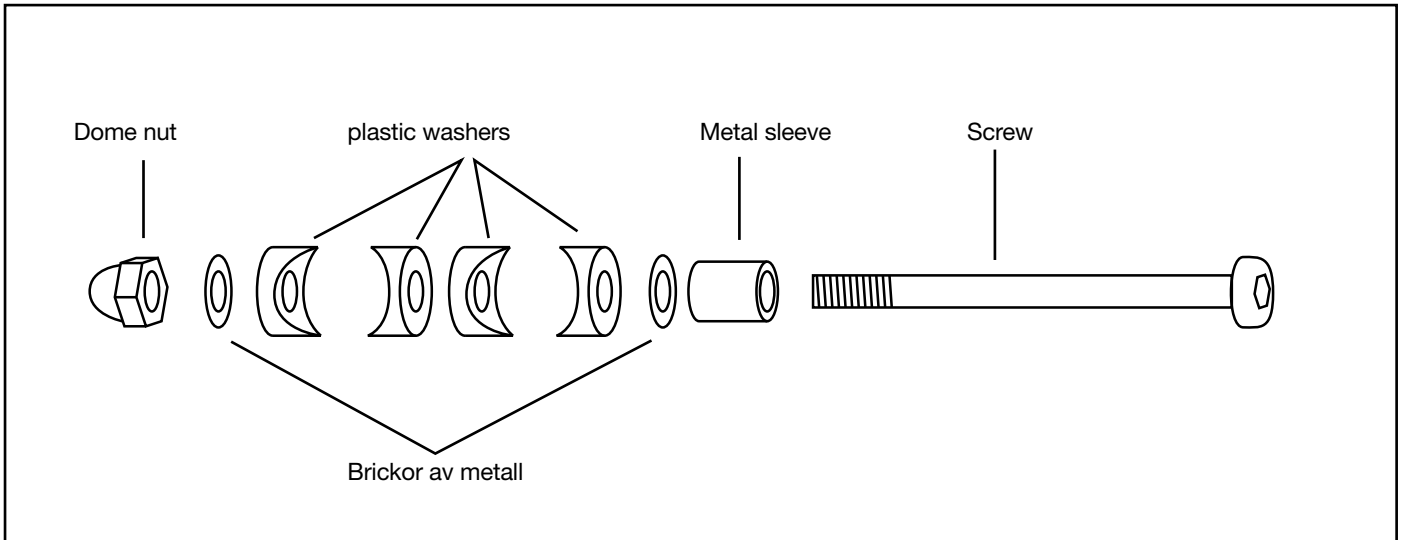

1. These are the parts of the joint and how they should be mounted together.

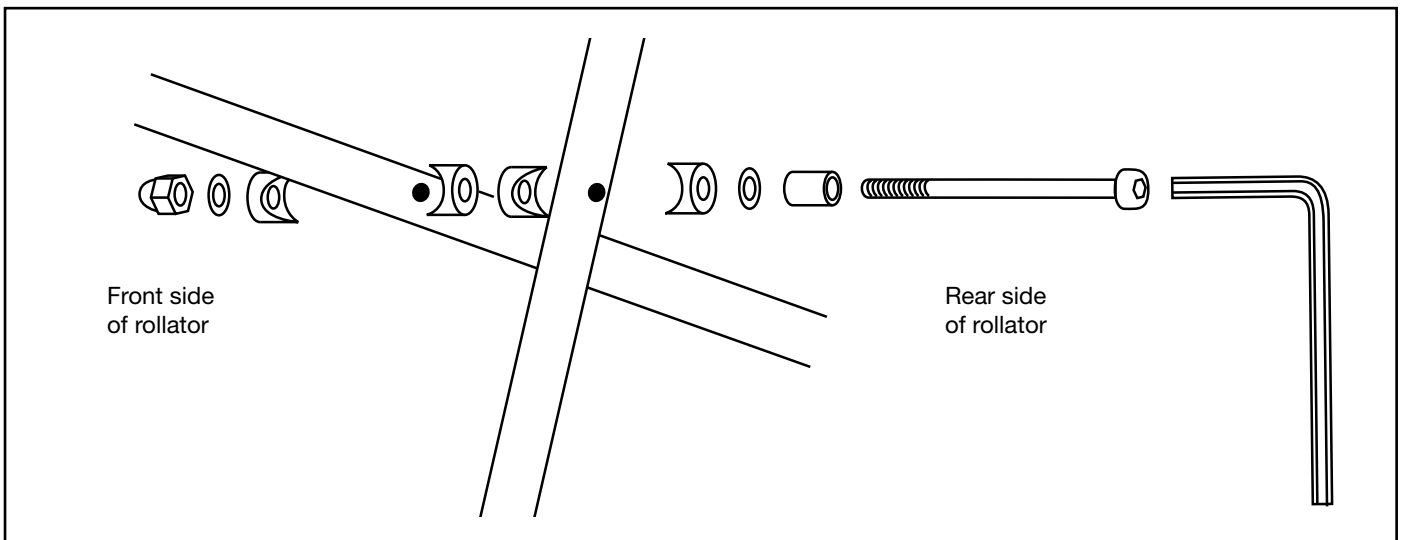

2. The tubes of the folding cross should be placed between the washers according to this sketch.

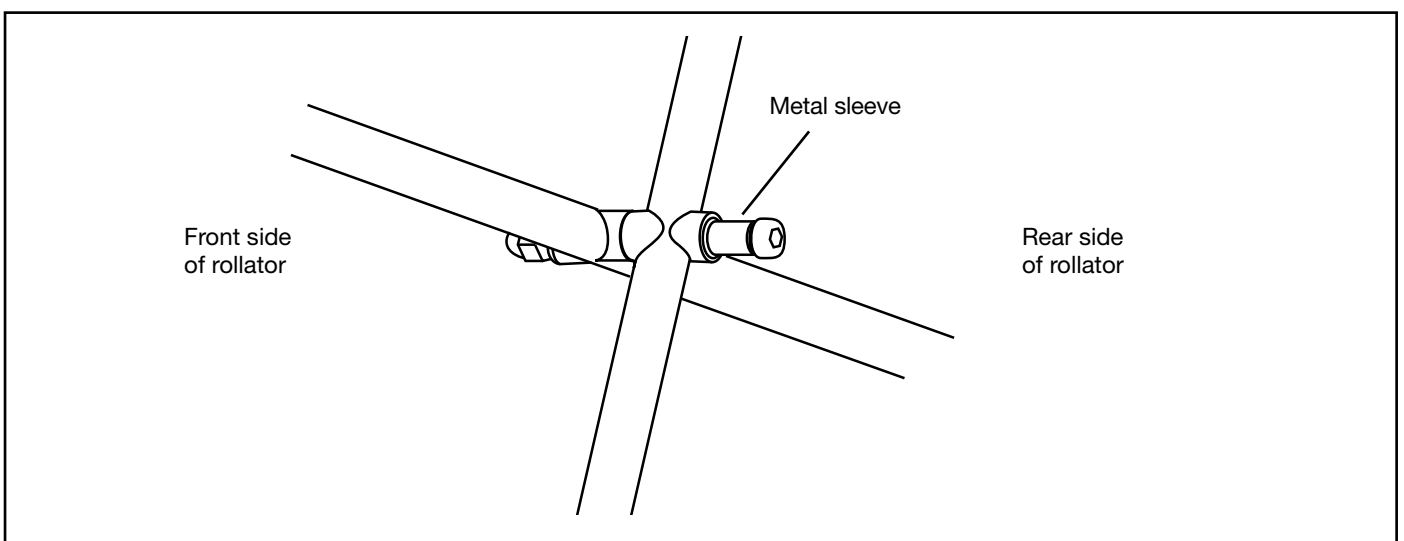

3. Tighten the dome nut securely. Fix the nut with a drop of Loctite so it will not fall off. The metal sleeve serves as a fixture peg for the hook when the rollator is folded.