

TECHNICAL DATA SHEET - **SmartMount**[®] Universal Flat Wall Mount for 32" to 50" Flat Panel Screens

MODELS: SF650, SF650-S, SF650P, SF650P-S



Boundless placement opportunities and speedy installations are delivered in one low-profile package. The ultra-slim SF650 adapts to any installation environment with its open wall plate architecture that delivers screen placement flexibility, simplified access to electrical access and cable management options. This ultra-slim mount is the supreme solution for low-profile applications.

Features:

- Universal mount fits screens with mounting patterns up to 29.23" W x 17.05" H
- Open wall plate architecture allows for total wall access, increasing electrical access and cable management options
- Ultra-slim design holds screen only 1.7" from the wall for a low-profile application
- Horizontal screen adjustment of up to 8" (depending on screen model) for perfect screen placement
- Universal brackets easily hook onto wall plate for fast installation
- Mounts to wood studs, concrete, cinder block or metal studs (metal stud accessory required)
- Comes with Peerless' Sorted-for-You™ fastener pack with all necessary screen attachment hardware
- Integrated security options available

Accessories:

- ACC415 - Metal Stud Fastener Kit (Metal Stud not evaluated by UL)
- SCS222 - SmartMount Component Shelf

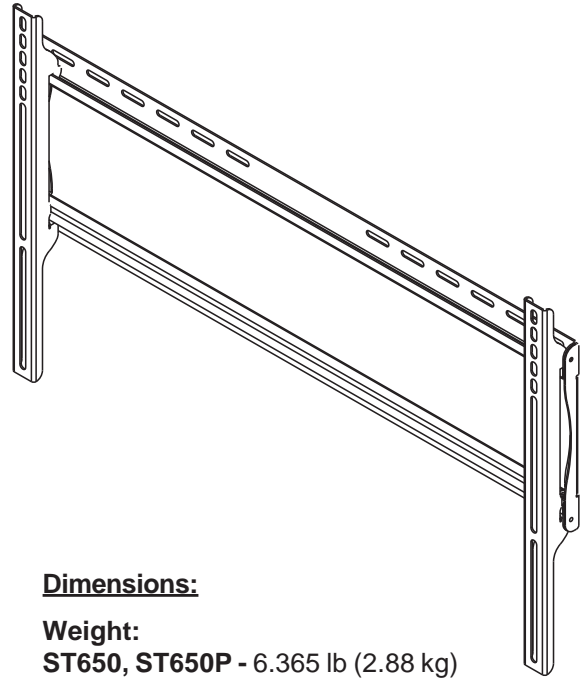

Dimensions:

Weight:

ST650, ST650P - 6.365 lb (2.88 kg)

ST650-S, ST650P-S - 6.375 lb (2.89 kg)

Shipping weight:

ST650, ST650P - 7.99 lb (3.62 kg)

ST650-S, ST650P-S - 8 lb (3.62 kg)

Maximum Load Capacity:

175 lb (79 kg)

Shipping Carton dimensions:

ST650, ST650P

L= 32.5 in (826 mm)

W= 10.125 in (258 mm)

H= 3.5 in (89 mm)

ST650-S, ST650P-S

L= 32 in (813 mm)

W= 10.063 in (256 mm)

H= 3.5 in (89 mm)

ARCHITECTS SPECIFICATIONS

The Universal Flat Wall Mount shall be a Peerless model _____ and shall be located where indicated on the plans. It shall be constructed of heavy gauge cold rolled steel and finished with scratch resistant Black or Silver Fused Epoxy. Assembly and installation shall be done according to instructions provided by the manufacturer.

TECHNICAL DATA SHEET

MODELS: SF650, SF650-S, SF650P, SF650P-S

ALL DIMENSION = INCH
(MM)



TOP VIEW

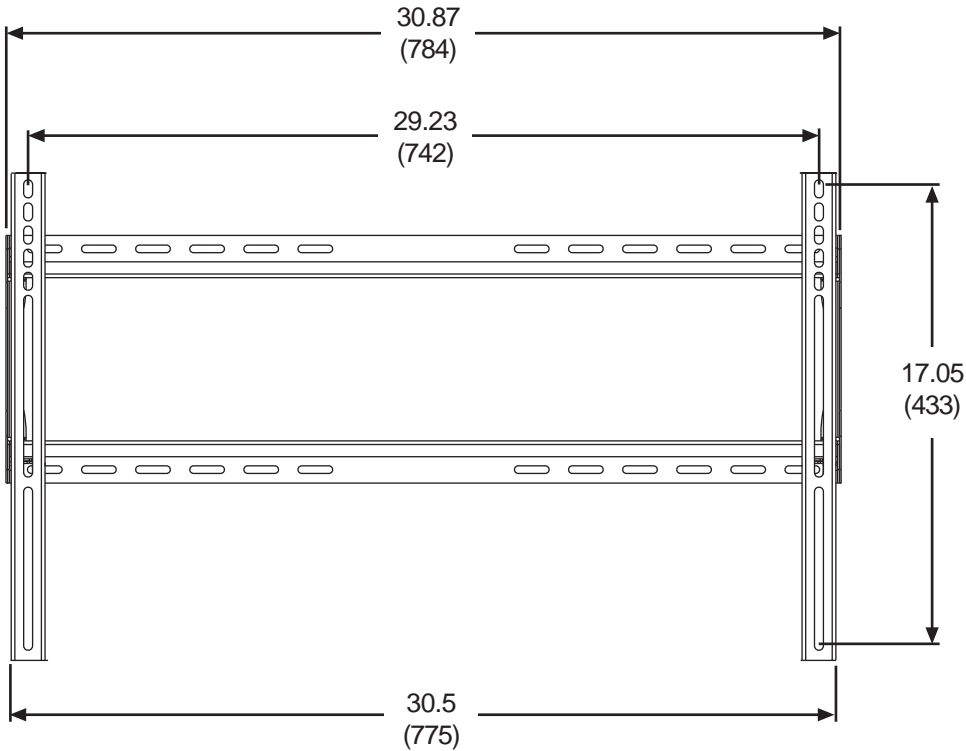

FRONT VIEW

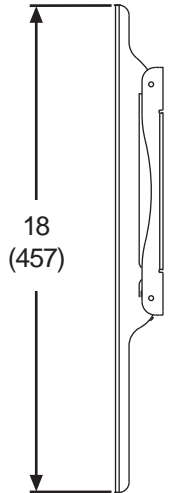

SIDE VIEW

TECHNICAL DATA SHEET

ALL DIMENSION = INCH
(MM)

MODELS: SF650, SF650-S, SF650P, SF650P-S

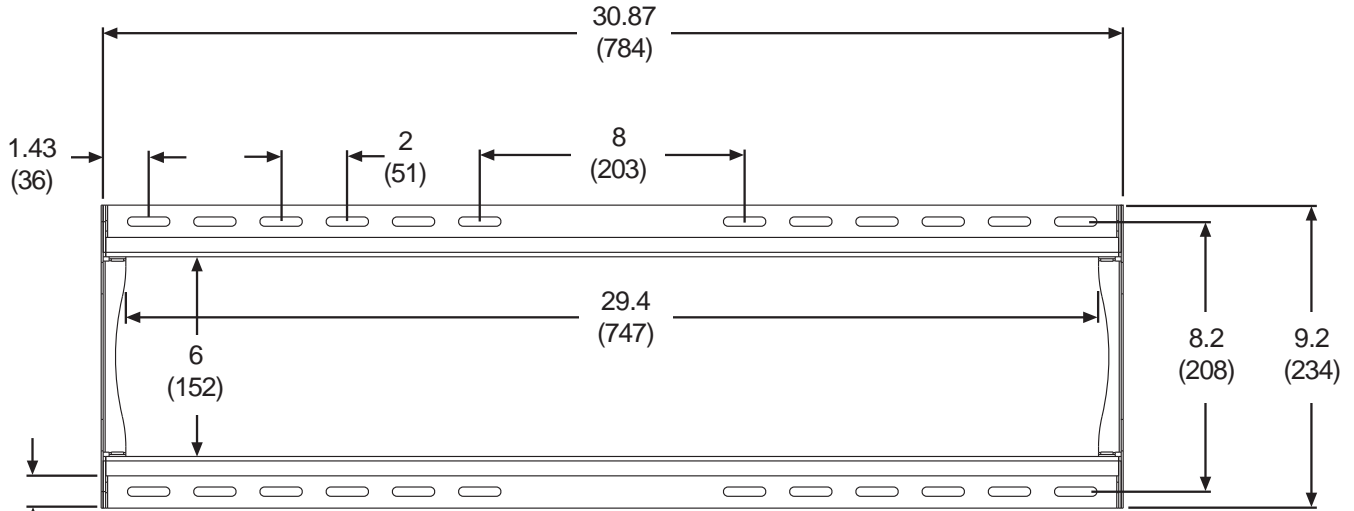

WALL PLATE DETAIL

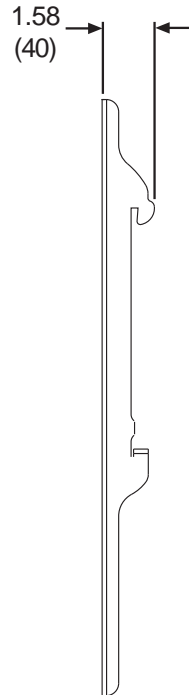

ADAPTER BRACKET DETAIL