

TECHNICAL DATA SHEET - Glass Shelf

MODELS: ACC317, ACC317-S, ACC318, ACC318-GB, ACC318-S

The ACC317, ACC317-S, ACC318, ACC318-GB, ACC318-S

Features:

- Colors: black with clear glass shelf, silver with clear glass shelf, black with tinted glass shelf, piano black with tinted glass shelf, or silver with tinted glass shelf
- same triangular shelf as FST550P
- 50 lb maximum weight capacity per shelf
- includes bracket and hardware

Dimensions:

Weight:

9.25 lbs (4.2 kg)

Shipping weight:

14.2 lb (6.44 kg)

Maximum Load Capacity:

50 lb (22.7 kg) per shelf

Shipping Carton dimensions:

L = 35.75 in (908 mm)

W = 22.5 in (572 mm)

H = 4.5 in (114 mm)

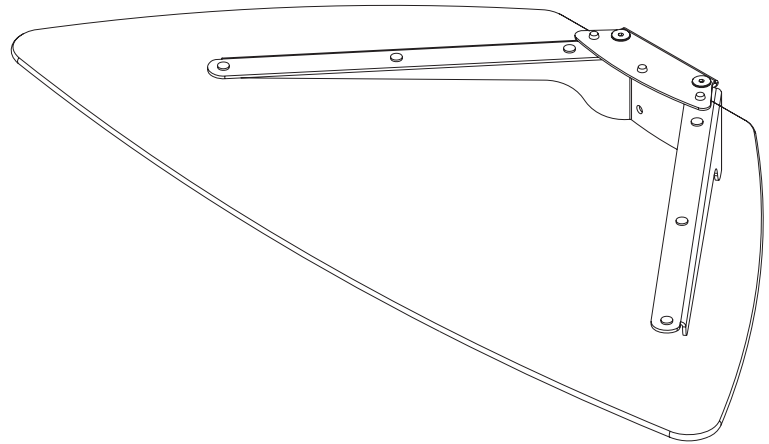

ARCHITECTS SPECIFICATIONS

The Shelf shall be a Peerless model **ACC317, ACC317-S, ACC318, ACC318-GB, ACC318-S** and shall be located where indicated on the plans. Assembly and installation shall be done according to instructions provided by the manufacturer.

TECHNICAL DATA SHEET

MODEL: ACC317, ACC317-S, ACC318, ACC318-GB, ACC318-S

All dimensions = inch (mm)

NOTE: For max. height of shelf refer to main instruction sheet.

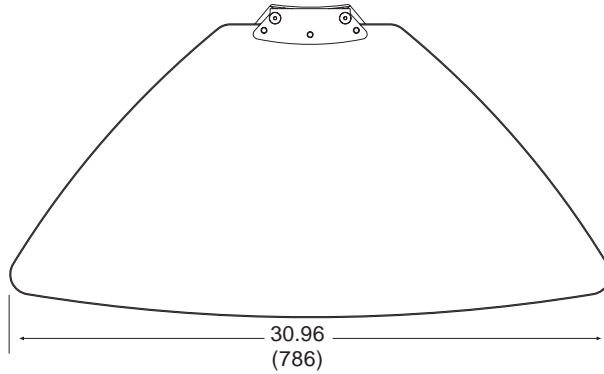

Top View

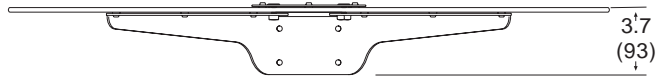

Front View

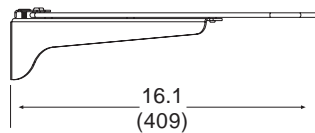

Side View