

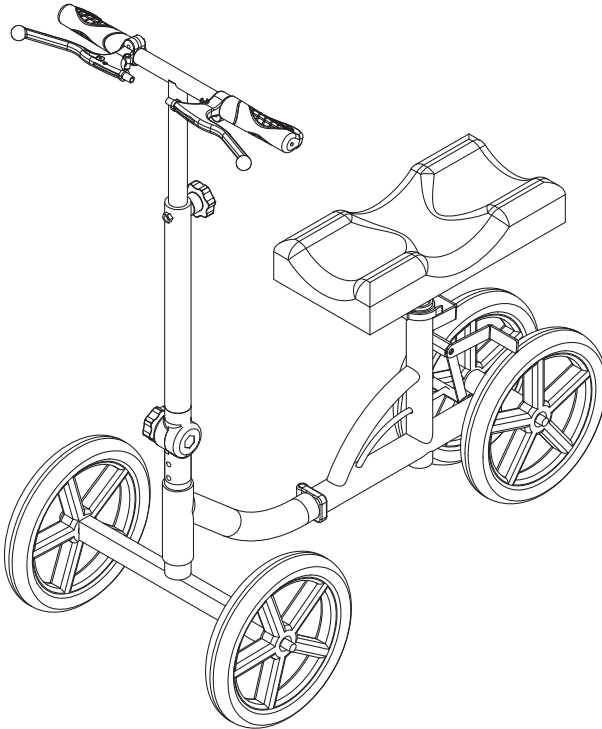

Knee Walker Operator's Manual



WARNING:

Carefully review and understand all INSTRUCTIONS prior to operating this device. Failure to follow the safety rules and other basic safety precautions may result in serious personal injury. Keep these instructions in a safe place and accessible so that they can be reviewed as required. Keep these instructions to assist in future servicing needs.

GENERAL SAFETY RULES

This Knee Walker is designed to maximize mobility during your recovery from foot injury or ankle injury including a surgery.

We recommend operating this Knee Walker at a safe walking speed (< 3 mph).

CAUTION: As with any new physical activity, instruction, practice, and common sense are necessary for successful use of the knee walker. Your health professional or knee walker distributor can provide instruction and a demonstration. Practice operating the knee walker to increase your skill and confidence.

⚠️ WARNING

Do not use this product without first reading and understanding this manual! If you are unable to understand the cautions, terms and conditions, and instructions, contact a healthcare professional, dealer, or qualified technician before using this product; otherwise, injury or damage may occur. Using this product acknowledges that you agree to these Terms and Conditions.

1. Because the knee walker is lightweight, use of the hand brake while in motion may cause an abrupt stop.
2. Do not use the knee walker on or near stairs or while using mind-altering drugs or alcohol or while suffering from dizziness.
3. Do not use the knee walker pull yourself up from a seated or other position. The knee walker is intended for use with a person in place on the scooter.
4. Use caution when moving from carpeted to hard surface floors and on any rough surfaces or when changing levels (for example, moving from a curb to the street and back onto the sidewalk).
5. Check the knee walker frequently for any loose cotter pins, clevis pin or loose nuts or bolts and the quick-release clamp on the T-tube. Do not use the knee walker if any pins are missing.

MAIN COMPONENTS

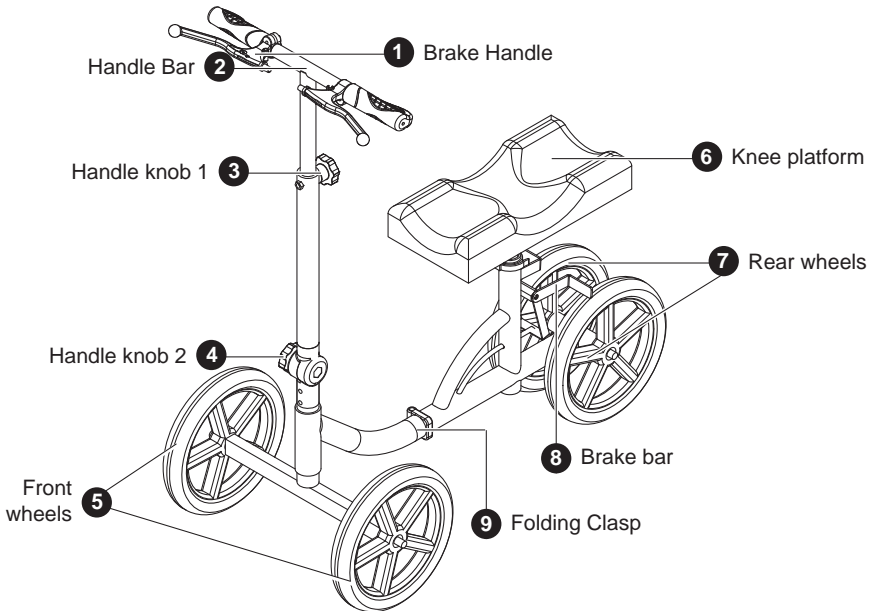

TECHNICAL DETAILS

SKU	GUT148
Rated Load	330lbs (150kg)
Wheel Size	12"
Handle bar height range	34.2"~39" (870~990mm)
Knee platform height range	20"~23.5" (510~600mm)
Net weight	16.5lbs (7.5kg)
Safety walking speed	< 3 MPH

ASSEMBLY

1. Folded Frame Setup

The knee walker will be in a folded position when unpacking it from the shipping carton. This feature also makes transporting the knee walker quick and convenient during everyday use.

Take scooter out of box. Slowly turn the folded frame to straight till the folding clasp closed.

Make sure the folding clasp lock before using.

If need to fold knee walker, push the button in folding clasp (1), and open the clasp (2), slowly turn back wheels sideward.

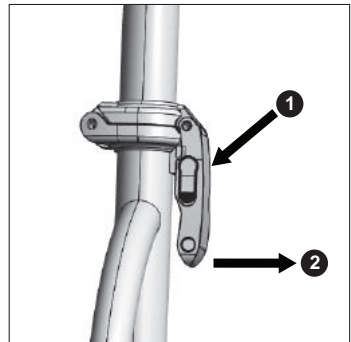

2. Handle Bar Setup

2.1. Insert handle bar to the frame. Use M6 bolts that go through the holes of handle bar and frame, and fix them with nuts.

2.2. Loosen the handle knob.

2.3. Lift the handle-bar up to a proper angle for yourself.

2.4. Tighten the handle knob to fix the handle bar.

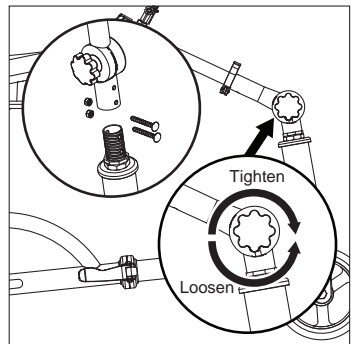

2.5. Handle bars are raised and lowered by adjusting the position of handle knob which is in middle of handle bar. Adjusting a proper height of handle bar by choosing a hole of bar. Handle bar should be set at waist level to keep you back straight.

WARNING

Be sure to check that the handle knob is secure and tight before each use, or injury may result.

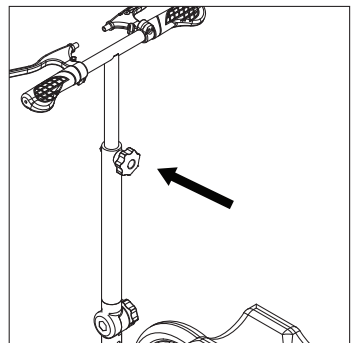

3. Knee Platform setup

The knee walker can be used for right or left leg injuries.

To adjust the platform, remove the D-sharp pin, lift the platform from its frame, choose a proper hole, insert the pin and lock the clamp on the opposite side. Reinsert the platform post and set it for the desired height.

The comfort knee platform height is that your injured leg is supported at a 90-degree angle when standing.

⚠️ WARNING

Injury may result if knee platform setup instructions are not followed

4. Brake Adjustment

For parking, the left brake handle is controlled mechanical brake which lock the rear wheels. When actuated brake handle, it will stop knee walker.

⚠️ WARNING

Because the knee walker is lightweight, use of the hand brake while in motion may cause an abrupt stop.

There is parking brake at front of handle. While actuated brake handle (1), press the parking brake (2), the rear wheels are locked, and knee walker is in parking situation.

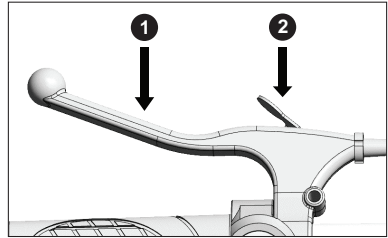

OPERATION

1. Place your hands on the handlebars.
2. Place the knee of your injured leg or foot on the front platform so that the top of your boot or cast is directly over the space between the platform. Your lower leg is then resting on the rear platform.
3. Release the parking brake and propel yourself forward or backward with your pushing foot, keeping the knee of your injured foot centered on the knee platform.
4. Move slowly so that you can stop safely using your pushing foot.
5. The hand brake may be used if needed but is primarily designed to maintain a stopped stance.

WARRANTY

Twelve (12) months for workmanship of the product, except for wearing parts. Warranty period starts from the product purchase date. Warranty covers material quality and workmanship only. Warranty does not cover product for issues caused by improper usage or any operation not in accordance with the specifications of this manual. Any modification or tampering with the product in any way voids the warranty.

