

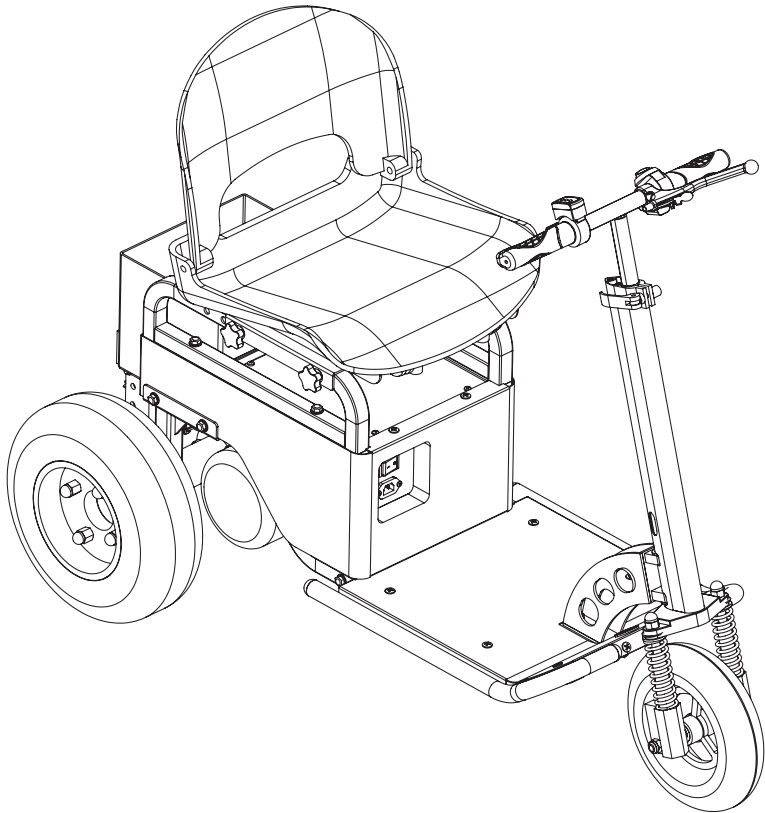

# Tugger Operator's Manual

---



**WARNING:**

Carefully review and understand all **INSTRUCTIONS** prior to operating this device. Failure to follow the safety rules and other basic safety precautions may result in serious personal injury. Keep these instructions in a safe place and accessible so that they can be reviewed as required. Keep these instructions to assist in future servicing needs.

---

## 1. WARNING

### **▲WARNING**

A tugger is not a toy. It is an electrically powered tugger and failure to follow safe operating procedures and safety warnings at all times could result in serious personal injury or death in addition to the injury or death of others.

- DO NOT Place your feet or hands under the tugger.
- Do NOT allow anyone other than the operator to stand in front of or behind the towing machine while it is in motion.
- DO NOT Overload the tugger.
- DO NOT Lift people. People could fall down and suffer severe injury.
- DO NOT Drive laterally or diagonally on ramps.
- DO NOT Refit the tugger without manufacturer's written consent.
- DO NOT Leave the tugger for a long time without turning off the power.
- Do NOT operate or service this machine while under the influence of any drugs or alcohol.
- NEVER make any alterations or modifications to this equipment including disabling safety devices or interlocks.
- Driving a tugger requires a combination of healthy traits and abilities, including but not limited to: good vision; strength; coordination; balance and concentration. If you have these traits and abilities, you are on the right track.
- Limit travel speed. Ground conditions, congestion, slope, location of personnel and other factors increase risk of collision or injury to personnel.

## 2. TECHNICAL SPECIFICATIONS

SKU#	GUO098	
<b>Performance</b>	Towing capacity	2600lbs (1200kgs)
	Load capacity	350lbs (160kgs)
	Max. forward speed*	4.3mph (7km/h)
	Max. backward speed*	1.9mph (3km/h)
	Max. slope*	15% (8.5°)
<b>Dimensions &amp; Weight</b>	Total dimension	51.2x25.2x37.4 in (1300x640x950mm)
	Handle height range	32.3~36.2 in (820~920mm)
	Seat size	16.9x 14.9 in (430x380mm)
	Seat adjustment	3 positions
	Tow bar adjustment	4 positions
<b>Tires &amp; Brakes</b>	Front tire size	10X2.5in (254x63mm)
	Front tire pressure	45±2psi
	Rear tire size	13X5in (330x127mm)
	Rear tire pressure	28±2 psi
	Brake Type	Manual hydraulic disc brake
<b>Motor</b>	Power	500W
	Rotate speed	3000RPM
	Input voltage	DC,48V
	Type	Brushless motor
<b>Battery system</b>	Output voltage	48V (12Vx4Cells)
	Capacity	9Ah
	Type	Lead-acid cell
	Operating temperature	+41~+104°F (+5~+40°C)
<b>Charger</b>	Input voltage	100-240V

Note: \*The maximum forward/backward speed and maximum slope range depend on the towed object, temperature , ground conditions, battery conditions and other factors. Actual maximum speed and range charges may vary.

### 3. CONTROLS AND FEATURES

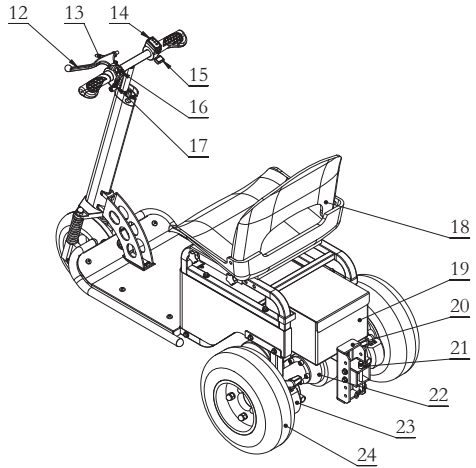
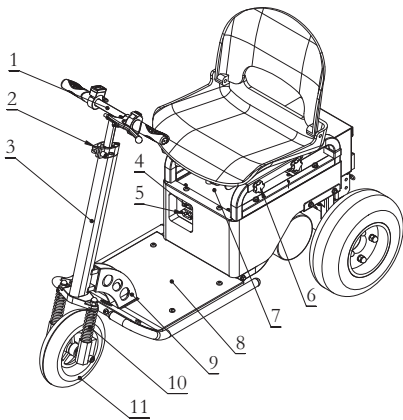

Part No.	Description	Part No.	Description
1	Handlebar	13	Parking brake
2	Handlebar adjustment clamp	14	Battery LED
3	Middle bar	15	Accelerator knob
4	Power Switch	16	Forward/Reverse switch
5	Charge port	17	Console switch
6	Star handle bolt	18	Seat
7	Battery box cover	19	Tool box
8	Foot plate	20	Towbar Mounting Base
9	Handlebar connector	21	coupling pin
10	Shock absorber	22	rear axle
11	Front wheel	23	Disc brake
12	Brake lever	24	Rear wheel

## 4. ASSEMBLY

### 4.1 Assemble Handlebar (See Fig. 1)

Place the fixing base (B) on the frame (A) and connect them first with 2 M8x20 bolts (C) and 2 M8 nuts (D), then fix them together completely with 2 M6x20 hex bolts (E) and 2 M6 nuts (F).

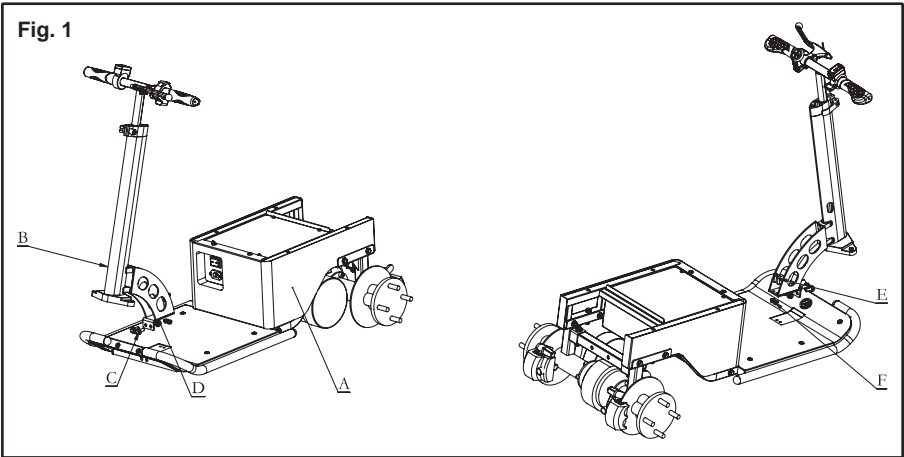

### 4.2 Assemble Rear Wheels (See Fig. 2)

Assemble the rear wheel to both ends of the axle (A) using 1 rear wheel (B), 4 elastic washers (C), and 4 M14x1.5 cap nuts (D).

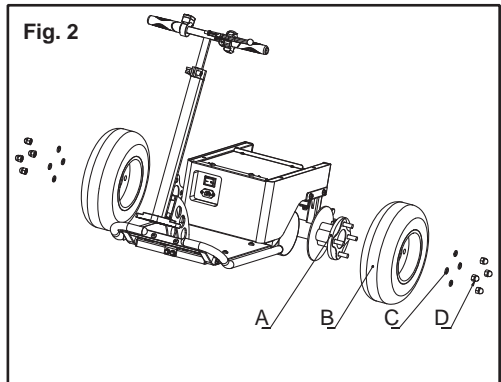

### 4.3 Assemble shock absorbers (See Fig. 3)

Assemble the 2 shock absorbers (B) to the middle bar (A) first, and then install them with 2 M12 cap nuts (C).

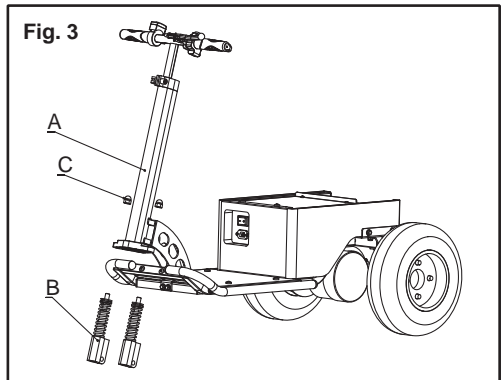

#### 4.4 Assemble Front Wheel (See Fig. 4)

Assemble the front wheel (D) to the shock absorber hits (A) with 2 spacers (C & D), 1 M12x160 hexagonal bolt (B) and 1 M12 nut (F).

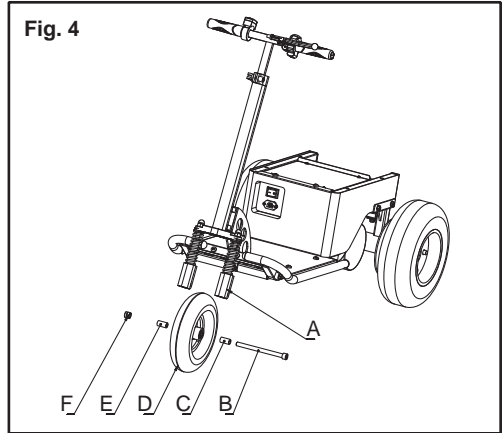

#### 4.5 Assemble Tow bar connector (See Fig. 5)

Assemble the towbar (B) to the axle (A) with 2 M8x55 bolts (C) and 2 M8 nuts (D).

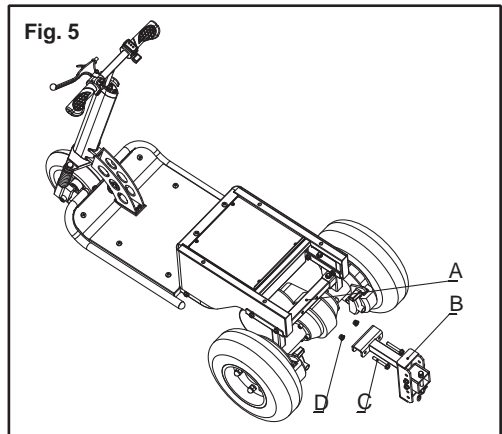

#### 4.6 Assemble Seat Frame (See Fig. 6)

Assemble the seat frame (B) to the mounting holes (A) on the tigger frame with 4 M8x40 bolts (C)

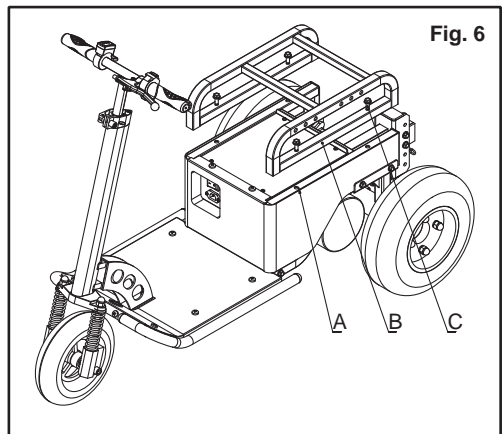

#### 4.7 Assemble Seat (See Fig. 7)

Secure the seat (B) to the seat frame (A) with 4 M8x15 star head bolts (C).

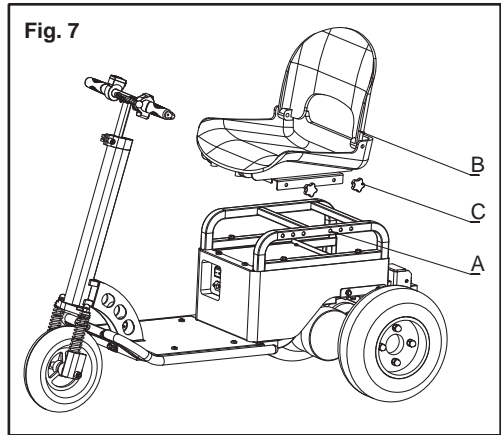

#### 4.8 Assemble Tool Box (See Fig. 8)

Assemble the Tool Bag (B) to the rear of the Frame (A).

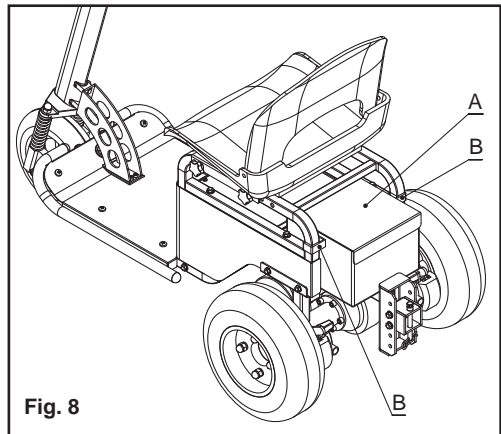

#### 4.9 Handlebar Height Adjustment (See Fig. 9)

Loosen the clamp (A) of the handle lock, adjust the handle to a proper position, and then tighten the lock of the handle lock.

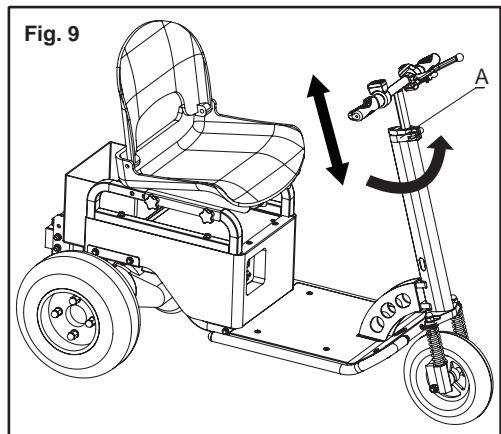

#### 4.10 Seat Position Adjustment (See Fig. 10)

Disassemble the 4 star-head bolts (A), adjust to the proper position, and then fix the four star-head bolts (A).

Loosen the four star head bolts (A), adjust them to the proper position, and then fix the four star head bolts (A)

**Note:** This tugger can be driven alone as a scooter to alleviate your traffic problems, and can also be used as a towing device to tow the trailer.

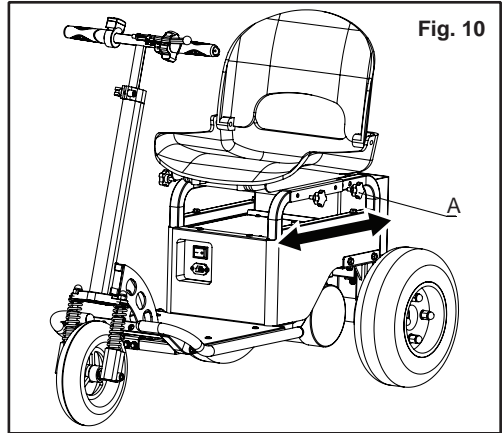

#### \* Tow bar connector height adjustment (See Fig. 11)

Disassemble the tow-bar connect kit(C) from the towbar mounting base(A), adjust it to the suitable position, then reinstall it with the bolts(B) and nuts(D)

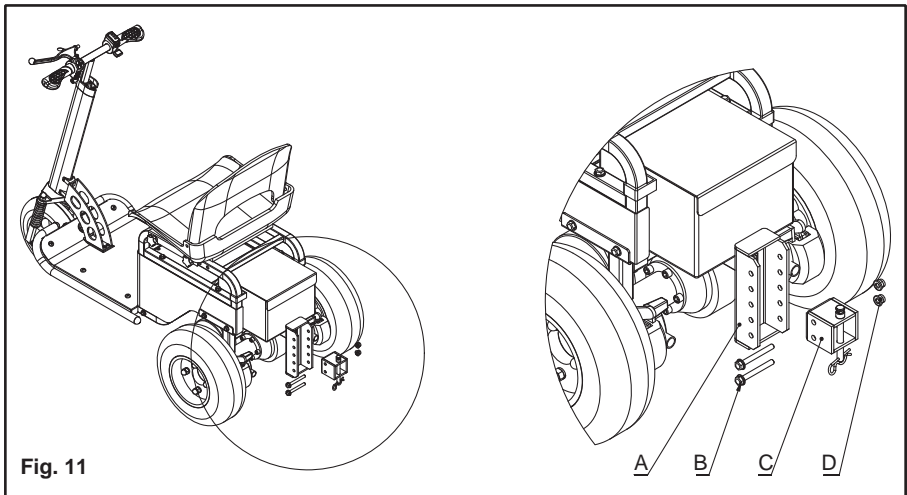

**\* Tow Bar Connection (See Fig. 12)**

Fix the towbar (C) on the connect kit (A) with the coupling pin (B), and insert the R pin (D) to secure the coupling pin(B).

**⚠ WARNING**

Do not tow objects from any point on the tugger other than the hitch provided. Towing from a point above the rear axle center line can cause the tugger to roll over backwards.

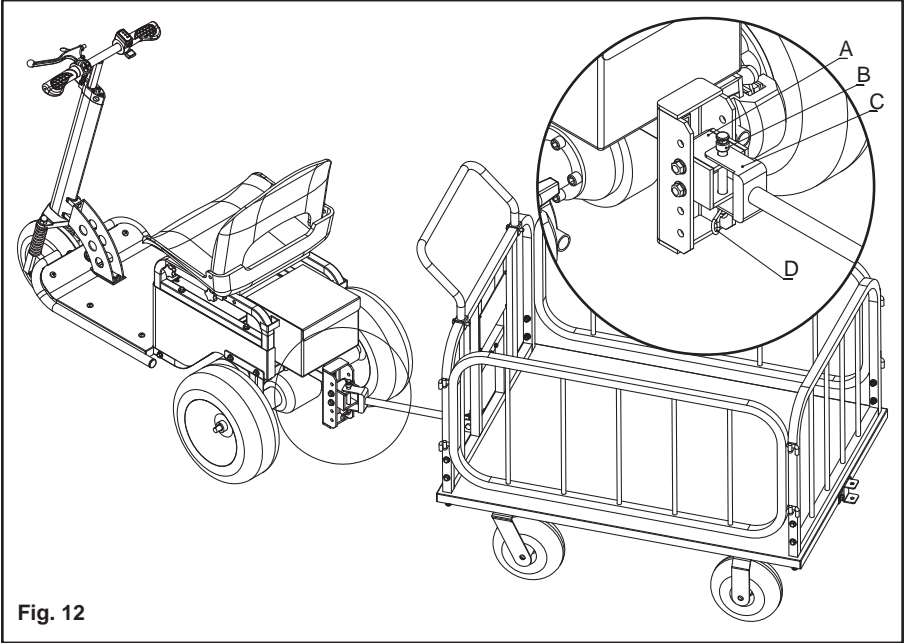

Fig. 12

**Note:** The tow bar and trailer mentioned here are not included in the product package, they need to be purchased separately.

**⚠ WARNING**

**Risk of being trapped and crushed!**

- Do not reach into the open coupling.
- Check the coupling pin (A) of the tow coupling for damage.
- Ensure that the R pin (C) engages in the locating hole .

**⚠ WARNING**

**After assembly, you have to do followings before firstly operating the tugger:**

- Check if all parts are not damaged.
- Check if all functions of the tiller work normally.
- Check if proper batteries and chargers are used.
- Do the work according to the daily inspections as well as functional checks.



## 5. OPERATION

### 5.1 General inspection before operation

General inspection is effective to find the malfunctions or faults on this tugger. Check the following items before operation.

DO NOT USE THE TUGGER IF ANY MALFUNCTION IS FOUND.

- Check for scratches, deformation or cracks.
- Check the vertical creep of the tugger.
- Check the smooth movement of the wheels.
- Check the function of the emergency brake.
- Check if all bolts and nuts are tightened firmly
- Visual check if there are any broken electric wires.
- Check that the load is safe and not overloaded
- Check if there is safety hazard around the tugger before starting

### **▲WARNING**

General rules cannot be written to cover every possible situation that may arise with each job function, task, or procedure. Therefore, certain definite responsibilities rest with you. These responsibilities include, protection of yourself, your fellow employees, along with proper care of tools and equipment. You are also responsible for reporting unsafe conditions, equipment, or operation to the proper authorities.

### 5.2 Indoor and outdoor use

Similar to an electric wheelchair, you are generally permitted to use the tugger inside of buildings, airports, shopping malls, stores, theaters, etc. Doors can be a challenge when using the tugger. Approach each door slowly making sure that the rear wheels will make it through the door opening. The tugger cannot go into door narrower than 24 inches (62cm).

The tugger should only be ridden on Paved pavement. It is not designed for off -road conditions. Do not use the tugger in rain or snow nor drive it through puddles of water. Slightly uneven surfaces should be approached at a reduced speed and in a direct frontal position and may require lifting or walking the tugger around the surface. Please keep in mind that the small wheels cannot roll over objects higher than 2 inches (5cm) and you may fall if you attempt to do so.

### **▲WARNING**

Always be alert to the area around your driving path to avoid hurting people or hitting objects!

### 5.3 Power On/Off (See Fig. 13)

For the power supply of the tugger, turn the power switch to the "I" position(A) for the power-on state, and hit the "O" position(B) for the power-off state.

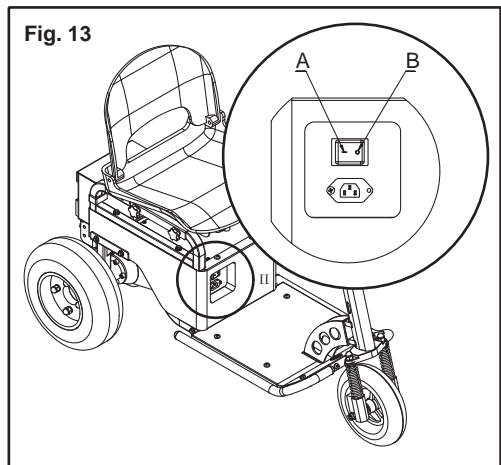

For the power supply of the console, the red knob in left hand side is the power switch. Push on it, power is On. Push on again, power is off. (See Fig. 14)

#### 5.4 BATTERY LEVEL INDICATOR (See Fig. 15)

LED on battery also shows battery capacity:

1. One LED: 0~40% battery capacity.
2. Two LED: 40%~70% battery capacity.
3. Three LED: 70%~100% battery capacity.

### **⚠WARNING**

Soft Riding Condition. When the battery is nearly depleted, a “soft” riding condition can occur. A “soft” riding condition means the tugger can move forward at lower speed compared with fully charged battery. When this happens, turn the tugger back on and drive the tugger under low speed until you can recharge the battery.

#### 5.5 Forward/Reverse Switch (See Fig. 16)

Control knob in left hand side. Push upward, tugger driving direction is forward. Push downward, driving direction is reverse. It is normal that you engage the tugger after one second when switch between forward/reverse. This one second is the protection of electrical system.

### **⚠WARNING**

Always be alert to the area around your driving path to avoid hurting people or hitting objects!  
Reversing the tugger is allowed only when nothing is being towed. Do not reverse backwards when towing multiple trailers, turn forward and make a U-turn!  
Always bring the unit to a complete stop before shifting from forward to reverse or from reverse to forward.

#### 5.6 Accelerator (See Fig. 17)

Use the right thumb to control the accelerator, Slowly push the accelerator knob to control the driving speed until reach the desired speed. If the accelerator knob is back to the neutral position, the controller slows the tugger until it stops.

**【WRANING】** Never operate at speeds that are not consistent with operating conditions. Always limit speed to ensure adequate time for braking in an emergency.

#### 5.7 Turn

It is essential to slow down to a reasonably slow speed before initiating a turn. Use extreme caution when turning on slanted or uneven surfaces. Occasionally you may find yourself negotiating a curve or corner too fast and the inner rear wheel starts to lift off the ground. If this happens, immediately reduce your speed, lessen the steering angle and shift your upper body toward the wheel that is lifting off the ground.

### **⚠WARNING**

Always be alert to the area around your driving path to avoid hurting people or hitting objects!

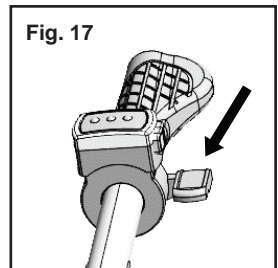
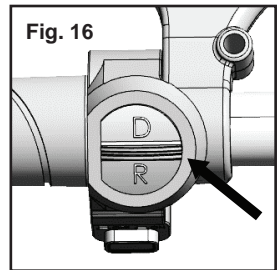
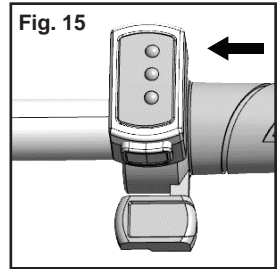
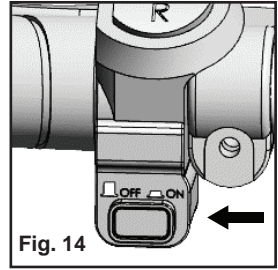

## 5.8 Brake & Parking (See Fig. 18)

The left brake handle is controlled mechanical brake which lock the brake in the right rear wheel. When actuated brake handle, It will slow the tigger down until it comes to a complete stop. Braking performance depends on road conditions and the load conditions and speed of the tigger. Release the brake and the tigger will be free again. Also, there is parking brake at front of handle. While actuated brake handle, press the parking brake, the right rear wheel is locked, and tigger is in parking situation. In a safe, controlled environment, please familiarize yourself with the braking distance of the tigger at different speeds before operating near intersections, pedestrians and other obstacles.

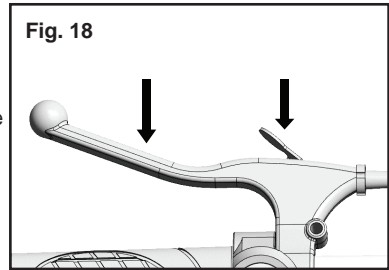

### **⚠ WARNING**

Do not drive or park the tigger laden for a long time on ramps. Park the tigger on firm and level ground.

Operators are not allowed to leave the tigger for a long time without power supply.

## 6. MAINTENANCE AND STORAGE

### 6.1 CHARGING

1. Turn the tigger power off.
2. Securely plug the charger into the charge port, and plug to power supply.
3. Connect battery to charger.
4. A solid red light on the charger indicates the battery is charging. A solid green light indicates the battery is fully charged.
5. Remove the plug from the power supply.
6. You will not damage the battery by riding the tigger until the battery is fully discharged and the tigger motor shuts down.

### **⚠ WARNING**

Use approved and from your dealer released original spare parts.

Charging place must be ventilated and equips with fire extinguishers.

### 6.2 Brakes Maintenance

1. Check the oil level in the oil cup from time to time. If it is too low or the brake does not brake, you need to open the oil cup cover and add brake oil.
2. If there is a brake that does not brake, replace the brake pads.
3. If there is a brake that does not brake, check whether the oil circuit is damaged, and if it is damaged, it needs to be replaced.
4. If the brake does not brake, check whether the oil pipe joint is leaking or loose, and if so, replace the gasket or fasten the bolt.

### **⚠ WARNING**

- Hydraulic fluid escaping under pressure can have sufficient force to enter eyes and penetrate skin. If fluid gets in eyes or skin, flush with large quantities of water and seek medical attention.
- Wear eye protection when servicing hydraulic components or systems.
- Keep all hoses and connections in good serviceable condition. Check before start-up and periodically during operation.
- Do not investigate for leaks with hands. Use a large piece of cardboard.

### 6.3 Battery Replacement



Only trained technicians are allowed to maintain, charge or replace the battery.

Use approved and from your dealer released original spare parts.

Only trained technicians are allowed to do maintenance on this tugger.

Before maintaining, turn off the power and remove the trailer from the tugger.

Recycling of batteries undergoes national regulations. Please follow these regulations.

Before starting repairs which do not require battery power, always turn off the key switch, then disconnect the battery connector from the battery to prevent accidental short circuit.

### 6.4 Transportation

Use proper crane equipment or forklift to place the tugger on the vehicle or other equipment for transportation, and fix the tugger as required.

During transportation on a lorry or truck always fasten the tugger securely.

Fix the tugger with a wedge in case of accidental movement.

The lashing band used should be strong enough.

Fix the loading and unloading AIDS (pallets, wedges) with anti-slide materials.

Or fasten the tugger via the man-up platform with lashing band.



Prior to hoisting equipment, ensure that no loose bars, tools, parts, and the like are lying in or on part of the unit, As they can cause serious injury to personnel and/or damage the unit.

### 6.5 Storage

Park the tugger safely and turn off the power to the tugger.

Keep machine clear of foreign objects and clean of grease/oil and other lubricants.

protect the tugger against corrosion and dust.

If you need to lift the tugger, before lifting the tugger, make sure the tugger cannot accidentally fall, move or slide to avoid injury or damage to the machine.



Check your tugger when you use it again, including the electronic control system, battery power, brakes, tire pressure, whether the installation is stable, etc.

## 7. WARRANTY

Twelve (12) months for workmanship of the product, except for wearing parts. Warranty period starts from the product purchase date. Warranty covers material quality and workmanship only. Warranty does not cover product for issues caused by improper usage or any operation not in accordance with the specifications of this manual. Any modification or tampering with the product in any way voids the warranty.

## 8. TROUBLE SHOOTING

Problem	Possible cause	Solution
<b>The scooter does not operate.</b>	The scooter is not turned on.	Turn on scooter by pressing power button.
	The battery is not charged.	Charge Battery.
	The hand brake and parking brake are inadvertently engaged.	Make sure hand brake and parking brake are not engaged.
	The battery is not locked and secured.	Secure battery by locking it in the housing.
	Main circuit was broken.	Contact customer service at our website ( <a href="http://www.greatcircleus.com">www.greatcircleus.com</a> ) or support line: 1-866-493-0524
<b>The Scooter Operates Intermittently.</b>	The battery capacity is low and cause soft riding condition.	Recharge Battery.
	The battery is not locked and secured into its base.	Secure battery by locking it in the housing.
<b>Short ride time or runs slow.</b>	Rider weight.	Do not exceed 275 lbs. (125 kg) maximum weight limit.
	Carry dolly or heavy luggage.	Do not carry any dolly and luggage.
	Riding conditions.	Use only on flat, dry surfaces. Avoid inclines and areas with debris on surface.
	Battery not fully charged.	Charge battery until full.
	Old/Damaged Battery.	Replace Battery.
<b>Scooter is not stopped after actuate brake handle, or, it is hard to actuate brake handle.</b>	Main circuit was not connecting securely.	Contact customer service at our website ( <a href="http://www.greatcircleus.com">www.greatcircleus.com</a> ) or support line: 1-866-493-0524
	Drum brake is too loosed, or too tighten	Adjust the screw at drum brake at both sides.

**Note:** If you are unable to troubleshoot the tugger after trying all the solutions listed above, contact your local dealer or our after sales department, who will be responsible for further troubleshooting.





