

ST800DR3 DUMBBELL RACK
OWNER'S MANUAL

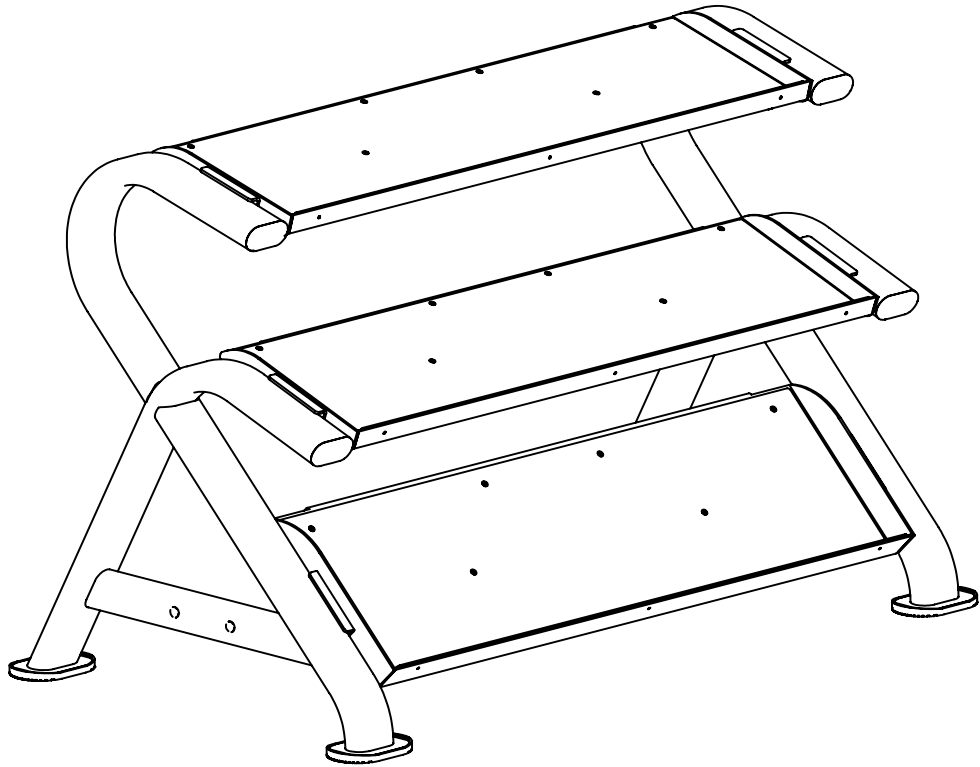

TABLE OF CONTENTS

3	PRODUCT REGISTRATION
4	IMPORTANT SAFETY INSTRUCTIONS
7	ASSEMBLY INSTRUCTIONS
15	RESISTANCE TRAINING BENEFITS AND TIPS
16	GENERAL MAINTENANCE
18	MANUFACTURER'S LIMITED WARRANTY

Thank you for purchasing our product, please save these instructions. Please do not perform or attempt any customizing, adjustments, repair or maintenance that is not described in this manual.



Congratulations on your new ST800DR3 Dumbbell Rack and welcome to the Spirit Fitness family!

Thank you for your purchase of this quality ST800DR3 Dumbbell Rack from Spirit Fitness. Your new ST800DR3 Dumbbell Rack was manufactured by one of the leading fitness manufacturers in the world and is backed by one of the most comprehensive warranties available. Through your dealer, Spirit Fitness will do all we can to make your ownership experience as pleasant as possible for many years to come. If not purchased direct from Spirit Fitness, the local dealership where you purchased this rack is your administrator for all Spirit Fitness warranty and service needs. Their responsibility is to provide you with the technical knowledge and service personnel to make your experience more informed and any difficulties easier to remedy.

Please take a moment at this time to record the name of the dealer, their telephone number, and the date of purchase below to make any future, needed contact easy. We appreciate your support and we will always remember that you are the reason that we are in business.

Yours in Health,
Spirit Fitness

NAME OF DEALER _____

DEALER PHONE # _____

PURCHASE DATE _____

RECORD YOUR SERIAL NUMBER

Please record the serial number of this fitness product in the space provided below. The serial number is located at the base of the rack.

SERIAL NUMBER: _____

REGISTER YOUR PURCHASE

The self-addressed product registration card must be completed in full and returned to Spirit Fitness.

WARNING

This product can expose you to chemicals including Toluene and Acrylamide which are known to the State of California to cause Cancer and birth defects or other reproductive harm.

IMPORTANT SAFETY INSTRUCTIONS

Read the owner's manual carefully before assembling, servicing or using the equipment. It is the responsibility of the facility owner and/or owner of the equipment to instruct users on proper operation of the equipment and review all labels.

WARNING: Serious injury could occur if these safety precautions are not observed:

USER SAFETY PRECAUTIONS

- Obtain a medical exam before beginning any exercise program.
- Stop exercising if feeling faint, dizzy or experiencing pain and consult your physician.
- Obtain instructions before using.
- Read and understand the owner's manual and all warnings posted on the rack before using.
- Keep all children (12 and under) away. Teenagers (13 and over) and disabled must be supervised.
- Keep body and clothing free from and clear of all moving parts.

- Use the rack only for the intended use. DO NOT modify the rack.
- Inspect rack prior to use. DO NOT use if it appears damaged or inoperable.
- DO NOT use if any components are worn, frayed or damaged.
- DO NOT attempt to fix a broken rack. Notify floor staff.
- Report any malfunctions, damage or repairs to the facility.
- Replace any warning labels if damaged, worn or illegible.
- TOTAL WEIGHT LIMIT: 1,000LBS

FACILITY SAFETY PRECAUTIONS

- Read the owner's manual carefully before assembling, servicing or using the equipment.
- Securely anchor each dumbbell rack to the floor using the anchor holes provided in each rack.
- Make sure that each rack is set up and operated on a solid level surface. Do not install equipment on an uneven surface.
- Make sure that all users are properly trained on how to use the equipment.
- Make sure there is enough room for safe access and operation.

- Perform regular maintenance checks on the equipment. Also pay close attention to all areas most susceptible to wear.
- Immediately replace worn or damaged components. If unable to immediately replace worn or damaged components then remove from service until the repair is made.
- Use only Spirit Fitness supplied components to maintain/repair the equipment.
- Keep a repair log of all maintenance activities.

NOTE: It is the sole responsibility of the user/owner or facility operator to ensure that regular maintenance is performed.

SAFETY GUIDELINES AND PRACTICES

Spirit Fitness recommends that all fitness equipment be used in a supervised area. It is recommended that the equipment be located in an access controlled area. Control is the responsibility of the owner. The extent of control is at the discretion of the owner.

It is the responsibility of the purchaser/user of Spirit Fitness products to read and understand the owner's manual, and warning labels; as well as instruct all individuals, whether end users or supervising personnel, on proper usage of the equipment.

PROPER USAGE

Use rack only as described in the manual. Failing to follow proper instructions may result in injury.

- Do not lean against or pull on the framework or any component, whether rack is at rest or in use. Inappropriate or improper use may result in injury to users or third parties (bystanders).
- Do not use rack if it is not located on a solid level surface or if it is not properly installed.
- Provide an adequate safety perimeter between the rack, walls and other equipment to ensure that the facility has the proper clearance for usage and training.

MAINTENANCE

Preventative maintenance allows proper equipment operation and reduces the risk of injury. Perform the maintenance requirements as specified in the manual (see table on page 16).

STANDARD COMPLIANCE

Spirit Fitness products meet or exceed applicable ASTM and EN Standards.

WARNING/CAUTION DECALS

- Warning decals indicate a potentially hazardous situation, which, if not avoided, could result in death or serious injury.
- Caution decals indicate a potentially hazardous situation, which, if not avoided, could result in minor or moderate injury.

SAVE THESE INSTRUCTIONS - THINK SAFETY!



ST800DR3 ASSEMBLY INSTRUCTIONS

ST800DR3 PRE-ASSEMBLY

To avoid possible damage to this ST800DR3 Dumbbell Rack, please follow these assembly steps in the correct order. Be sure to read your Assembly/Owner's Guide before using your new ST800DR3 Dumbbell Rack.

NOTE: During assembly, it is recommended to ensure that all bolts are in place and partially threaded before completely tightening any one bolt.

UNPACKING

1. Cut the straps, then pull the staples away from the bottom half and lift the top half of the carton off of the bottom
2. The hardware is located in the holes of the associated tubes/brackets

ST800DR3 TOOLS REQUIRED & PARTS LIST

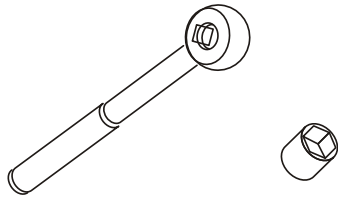

RATCHET WRENCH
AND SOCKET

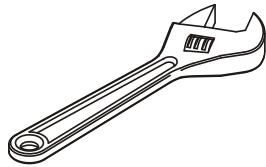

ADJUSTABLE WRENCH

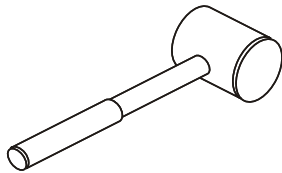

RUBBER Mallet

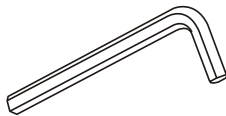

HEX KEY WRENCH SET

Item No.	Description	QTY
1	Left Frame	1
2	Right Frame	1
3	Dumbbell Tray	2
4	Big Dumbbell Tray	1
5	Tray Plate	2
6	Tray Side Plate	1
7	Plugs $\phi 11$	8
8	Tray Side Plate 1285 x 57 x 3	1
9	Tray Side Plate 1285 x 32 x 3	2
10	Plug RT50 x 100	4
11	Foot Cover	4
12	Flat Head Cap Screw M5 x 6	39
13	Flat Washer $\phi 13$ x $\phi 24$ x 1.5	24
14	Nylon Lock Nut M12	12
15	Hex Head Screw M12 25	12

ST800DR3 EXPLODED VIEW

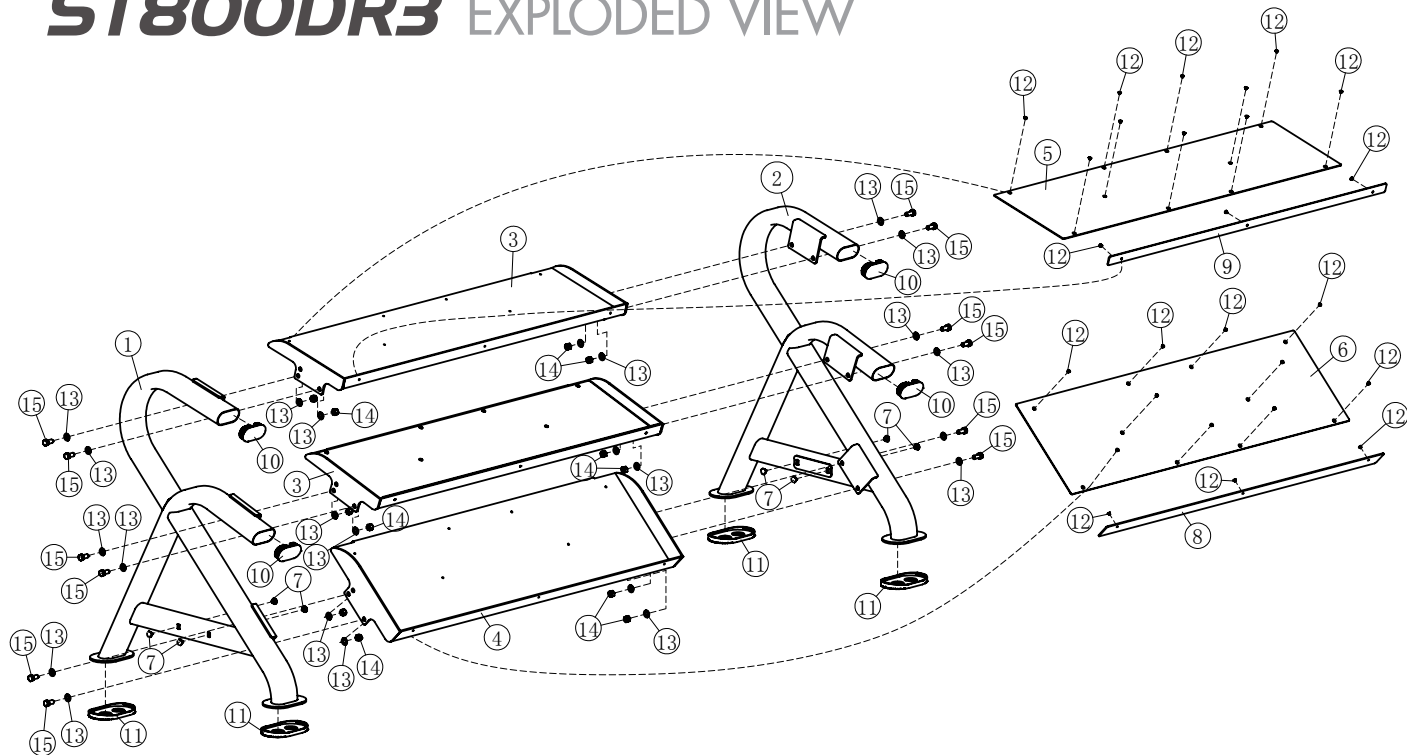

ST800DR3 ASSEMBLY INSTRUCTIONS

Assembly of the equipment takes professional installers approximately 1 hour. If this is the first time you have assembled this type of equipment, plan to spend more time. It is highly recommended to use professional installers to assemble the equipment. You may find it quicker, safer, easier to assemble with the assistance of another person as some components of the unit are large and heavy.

It is important that you assemble your product in a clean, clear, uncluttered area. This will enable you to move around the product whilst you are fitting components and reduce the possibility of injury during assembly.

Note:

As with any assembled part, proper alignment is critical. While tightening the fasteners, be sure to leave room for adjustments. Do not fully tighten the fasteners until instructed to do so. Be careful to assemble the components in the sequence presented in this manual.

ST800DR3 STEP ONE

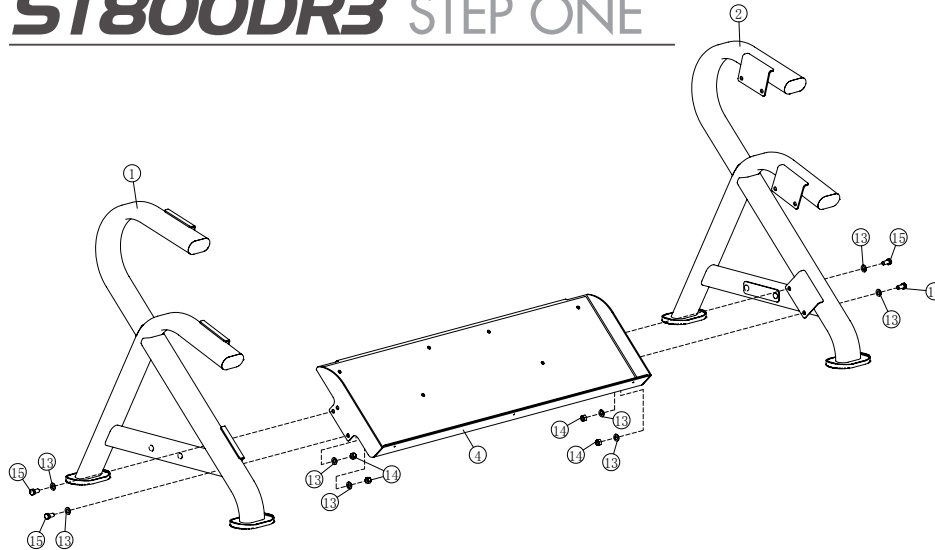

Connect the **Left Frame (No. 1)** the **Big Dumbbell Tray (No. 4)**.

Secure with:

- 2 **M12 x 25 Hex Head Bolts (No. 15)**
- 4 **Flat Washers $\phi 13 \times \phi 24 \times 1.5$ (No. 13)**
- 2 **Nylon Lock Nuts M12 (No. 14)**

Repeat with the **Right Frame (No. 2)**. Hand tighten bolts and nuts.

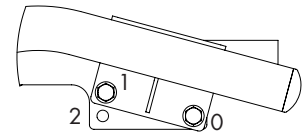

You can choose between two angles. Place bolts in holes 0 & 1 for a more tilted tray. 0 & 2 for a less tilted tray.

ST800DR3 STEP TWO

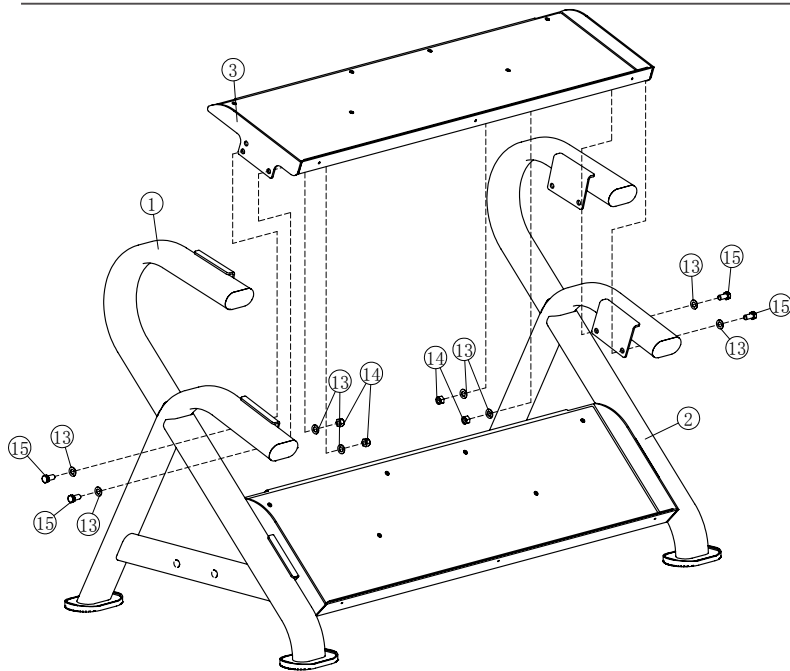

Attach Dumbbell Tray (No. 3) to the Left Frame (No. 1).

Secure with:

2 M12 x 25 Hex Head Bolts (No. 15)

4 Flat Washers $\phi 13 \times \phi 24 \times 1.5$ (No. 13)

2 Nylon Lock Nuts M12 (No. 14)

Repeat with the Right Frame (No. 2).

You can choose between two angles. Place bolts in holes 0 & 1 for a more tilted tray. 0 & 2 for a less tilted tray.

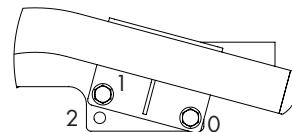

ST800DR3 STEP THREE

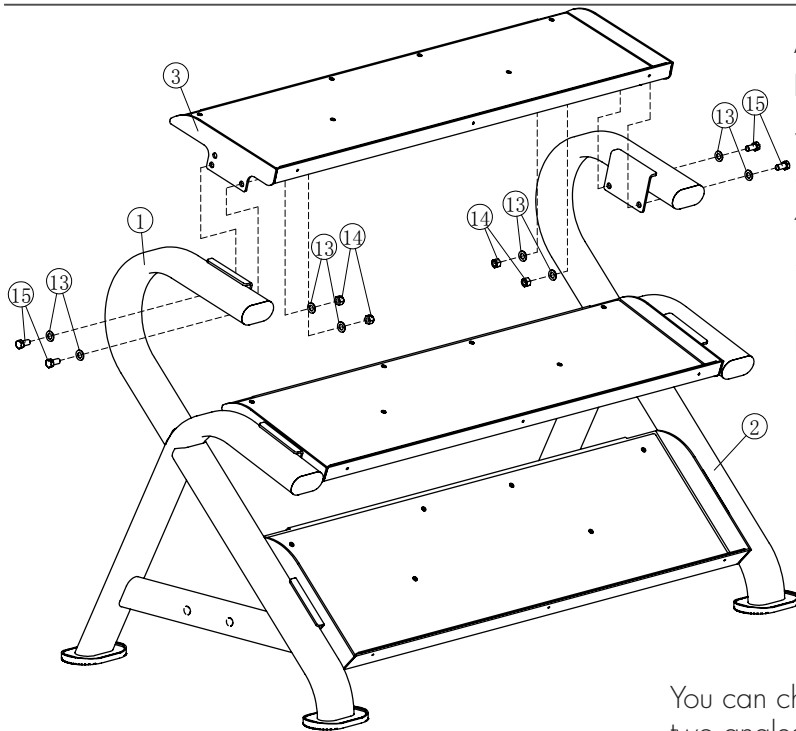

Attach **Dumbbell Tray (No. 3)** to the **Left Frame (No. 1)**.

Secure with:

- 2 **M12 x 25 Hex Head Bolts (No. 15)**
- 4 **Flat Washers $\phi 13 \times \phi 24 \times 1.5$ (No. 13)**
- 2 **Nylon Lock Nuts M12 (No. 14)**

Repeat with the **Right Frame (No. 2)**.

You can choose between two angles. Place bolts in holes 0 & 1 for a more tilted tray. 0 & 2 for a less tilted tray.

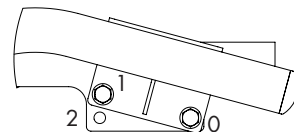

RESISTANCE TRAINING BENEFITS AND TIPS

Always consult a physician before starting an exercise program. To be successful in your exercise program, it is important to develop an understanding of the basic principles of resistance training. Now that you have assembled your Spirit Fitness rack, it is only natural that you want to get started immediately. First, determine a few realistic, short term goals and expectations for yourself. Choose an appropriate exercise routine that best suits your individual needs.

- Warm up properly before engaging in resistance training. Stretching, yoga, jogging, calisthenics, or other cardiovascular exercise can help prepare your body for the heavier workload of lifting weights.
- Learn how to perform the exercise correctly before using heavy weight. Correct form is important to avoid injury and ensure that you work the proper muscle groups.
- Know your limitations. If you are new to resistance training or are starting back, after an extended layoff, start slowly and build foundational strength over a longer period of time.
- Pay attention to your breathing. As a general rule of thumb: inhale on the non-exertion part of the movement and exhale during the exertion portion. Never hold your breath.
- Keep in mind how important the recovery phase is in achieving your goals. The general rule is to allow a minimum of 48-72 hours before training the same muscles. If you still experience soreness after this period of time has elapsed, take a few additional days until the soreness has subsided.
- To achieve maximum results and avoid possible injury, consult a fitness professional to formulate a complete exercise program.

GENERAL MAINTENANCE

For best performance, Spirit recommends the following maintenance schedule. Check the integrity and function of the following parts. Replace all worn components immediately.

ROUTINE	COMMERCIAL	HOME	LATEST DATE ENTRY
Clean: Upholstery	Daily	Weekly	
Inspect: All Decals	Weekly	3 Months	
Inspect: All Nuts and Bolts, Tighten if needed	Weekly	3 Months	
Inspect: Anti-Skid Surface	Weekly	3 Months	
Clean and Wax: All Glossy Finishes	6 Months	Yearly	

SANITIZING YOUR SPIRIT FITNESS EQUIPMENT

- Unupholstered high-contact surfaces (hard plastics) can be sanitized using a 75% isopropyl alcohol solution and a clean, dry cloth. Spray surfaces to be sanitized, and use the dry cloth to wipe clean. Allow surfaces to dry before using.
- For upholstered or soft-plastic surfaces, use a conditioner after sanitizing. Be sure to follow the instructions provided by the conditioner manufacturer to ensure proper use of the conditioner.
- Alternatively, you can make your own spray by mixing the proper ratio of isopropyl alcohol and distilled water to reach a 75% solution.

ST800DR3 DUMBBELL RACK WARRANTY

EFFECTIVE NOVEMBER 24, 2021

Spirit Fitness warrants the ST800DR3 Dumbbell Rack for a period of time listed below from the date of sale, as determined by sale receipt, or in the absence of a sales receipt eighteen (18) months from the original factory shipping date. Spirit Fitness' responsibilities include providing new or remanufactured parts, at Spirit Fitness' option, and technical support to our independent dealers and servicing organizations. In the absence of a dealer or service organization, these warranties will be administered by Spirit Fitness directly. The warranty period applies to the following components:

	Frame	ABS Protective Tray Sheets
Residential (vendor defects only)	Lifetime	Lifetime
Commercial (non-dues paying facilities)	10 Years	6 Months

*Prisons and correctional facilities are excluded from warranty coverage.

NORMAL RESPONSIBILITIES OF THE FACILITY

The facility is responsible for the items listed below:

1. The warranty registration card must be completed and returned to the address listed on the card within 10 days of the original purchase, or completed online to validate the manufacturer's limited warranty.
2. Proper use of the fitness equipment in accordance with the instructions provided in this manual.
3. Expenses for making the fitness equipment accessible for servicing, including any item that was not part of the fitness equipment at the time it was shipped from the factory.
4. Damages to the fitness equipment finish during shipping, installation or following installation.
5. Routine maintenance of this unit as specified in this manual.

EXCLUSIONS

This warranty does not cover the following:

1. CONSEQUENTIAL, COLLATERAL, OR INCIDENTAL DAMAGES SUCH AS PROPERTY DAMAGE AND INCIDENTAL EXPENSES RESULTING FROM ANY BREACH OF THIS WRITTEN OR ANY IMPLIED WARRANTY. *NOTE: Some states do not allow the exclusion or limitation of incidental or consequential damages, so this limitation or exclusion may not apply to you.*
2. Service call reimbursement to the facility. Service call reimbursement to the dealer that does not involve malfunction or defects in workmanship or material, for units that are beyond the warranty period, for units that are beyond the service call reimbursement period, for fitness equipment not requiring component replacement, or fitness equipment not in non-dues paying facility or household use.
3. Damages caused by services performed by persons other than authorized Spirit Fitness service companies; use of parts other than original Spirit Fitness parts; or external causes such as corrosion, discoloration of paint or plastic, alterations, modifications, abuse, misuse, accident, improper maintenance, inadequate power supply, or acts of God.
4. Products with original serial numbers that have been removed or altered.
5. Products that have been: sold, transferred, bartered, or given to a third party.
6. Products that do not have a warranty registration card on file at Spirit Fitness. Spirit Fitness reserves the right to request proof of purchase if no warranty record exists for the product.
7. THIS WARRANTY IS EXPRESSLY IN LIEU OF ALL OTHER WARRANTIES EXPRESSED OR IMPLIED, INCLUDING THE WARRANTIES OF MERCHANTABILITY AND/OR FITNESS FOR A PARTICULAR PURPOSE.
8. Product used in prisons and correctional facilities

Warranties outside of the United States may vary. Please contact your local dealer for details.

SERVICE

Keep your bill of sale. Twelve (12) months from the date on the bill of sale or eighteen (18) months from the date of factory shipping as determined by the serial number establishes the labor warranty period should service be required. If service is performed, it is in your best interest to obtain and keep all receipts. This written warranty gives you specific legal rights. You may also have other rights that vary from state to state. Service under this warranty must be obtained by following these steps, in order:

1. Contact your selling authorized Spirit Fitness dealer. OR
2. Contact your local authorized Spirit Fitness service organization.
4. Spirit Fitness' obligation under this warranty is limited to repairing or replacing, at Spirit Fitness' option, the product through one of our authorized service centers. All repairs must be preauthorized by Spirit Fitness.
5. The owner is responsible for adequate packaging upon return to Spirit Fitness. Spirit Fitness is not responsible for damages in shipping. Make all freight damage claims with the appropriate freight carrier. DO NOT SHIP ANY UNIT TO OUR FACTORY WITHOUT A RETURN AUTHORIZATION NUMBER. All units arriving without a return authorization number will be refused.

Product features or specifications as described or illustrated are subject to change without notice. All warranties are made by Spirit Manufacturing, Inc. This warranty applies only in the 48 contiguous United States. NOTE: This does not apply to Alaska or Hawaii.