

PROTONE SPEC SHEET

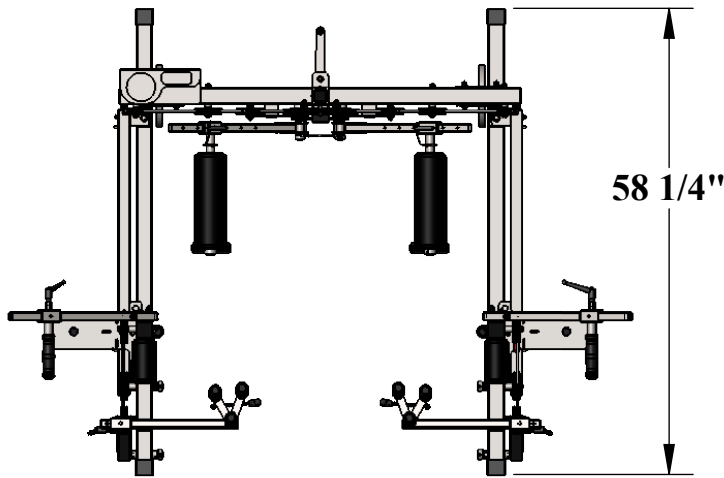

OVERHEAD VIEW

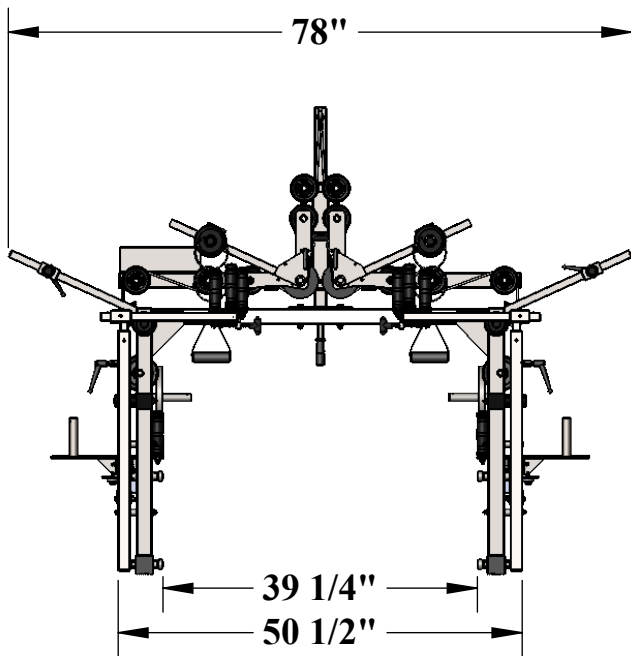
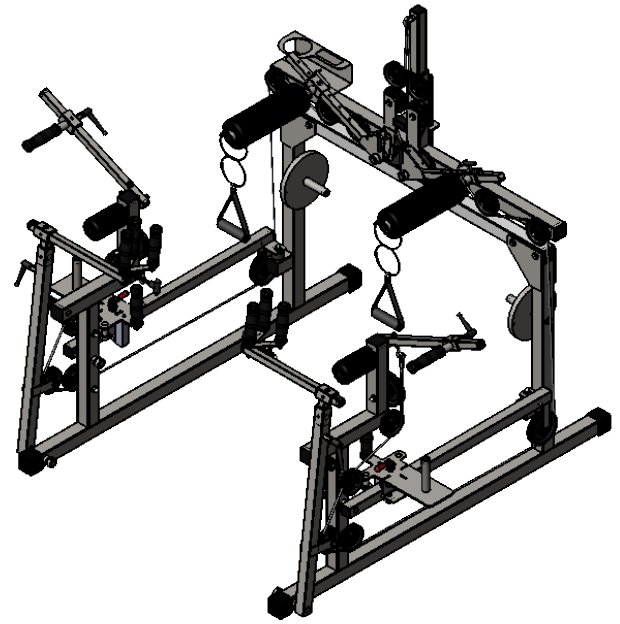

FRONT VIEW

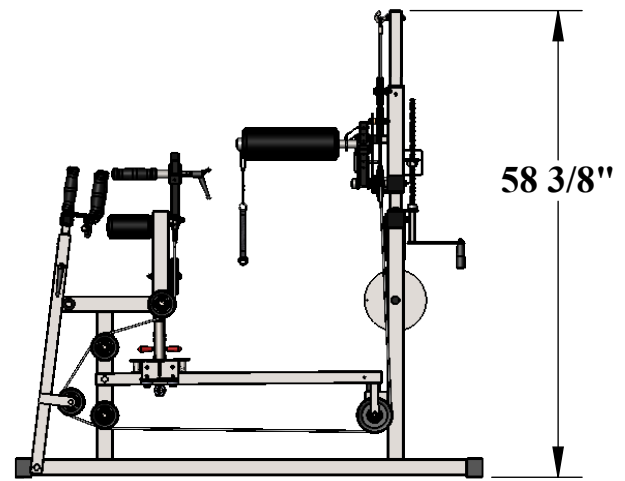

SIDE VIEW

SPECIFICATIONS:

MATERIAL: 304 STAINLESS STEEL

FINISH: WHITE POWDER COAT

PRODUCT WEIGHT: 202 LBS

WARRANTY: 3 YEAR STRUCTURE (NOT INCLUDING POWDER COAT FINISH)

1 YEAR ALL MOVING PARTS

SHIPS TRUCK FREIGHT IN THREE BOXES WITH SOME ASSEMBLY REQUIRED

NOTE:

*SPECIFICATIONS ARE SUBJECT TO CHANGE WITHOUT NOTICE

PRODUCT:		PROTONE	
PART #:		F-PTN	
SCALE:	1:24	DATE:	11/10/2020
DRAWN BY:	KR	REVISION:	00