

FLEXION FOOTBOX™ - SINGLE



FLEXION FOOTBOX™ - SINGLE

Parts Included:

Pre-Attached

- 1 - (A) Screw 1/4-20 x 1/2" Button Head
- 1 - (B) Washer 0.25" ID, 0.75" OD

From Kit Bag

- 1 - (C) Allen Wrench 5/32
- 2 - (D) Screw 1/4-20 x 1.25" Phillips Pan Head
- 2 - (E) Screw 1/4-20 x 1" Phillips Pan Head
- 2 - (F) Washer Internal Tooth, 5/16" ID
- 4 - (G) Washer 0.25" ID, 1.25" OD
- 2 - (H) Nut 1/4-20 Nylon Lock

- 1 Remove center foam/cover piece.
- 2 Place the Flexion Footbox on the wheelchair footplates in the required position.
- 3 Drill 2 mounting holes through the bottom of the wheelchair footplates and through the bottom of the Flexion Footbox plate as shown in Figure 1. Holes must be big enough for a 1/4"-20 screw.
- 4 Attach the Flexion Footbox to the foot plate with screw (D or E) depending on the thickness of the foot plate; along with the washer (F), washers (G), and nut (H) using Allen Wrench (C) as shown in Figure 2.
- 5 Reattach the center foam/cover piece.
- 6 Remove screw (A) and washer (B) on both sides using Allen Wrench (C) as shown in Figure 2.
- 7 Adjust the angle of the Flexion Footbox to the required position as shown in Figure 3 and then reattach screw (A) and washer (B) to lock the Flexion Footbox in place.

FIGURE 1: MOUNTING HOLES

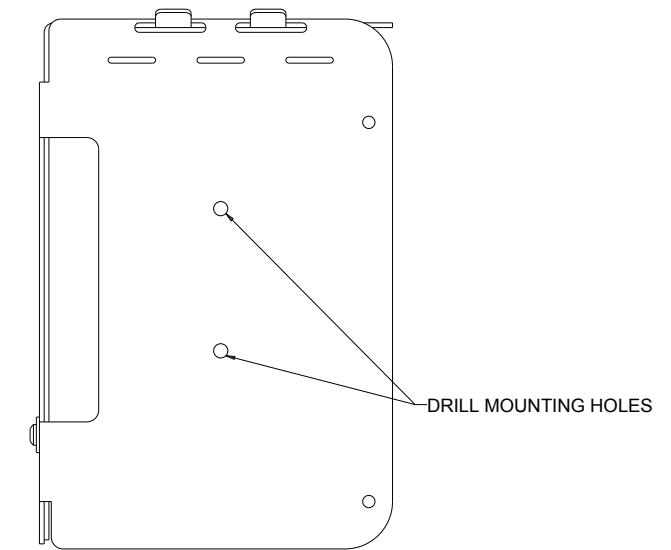

FIGURE 2: HARDWARE ATTACHMENT

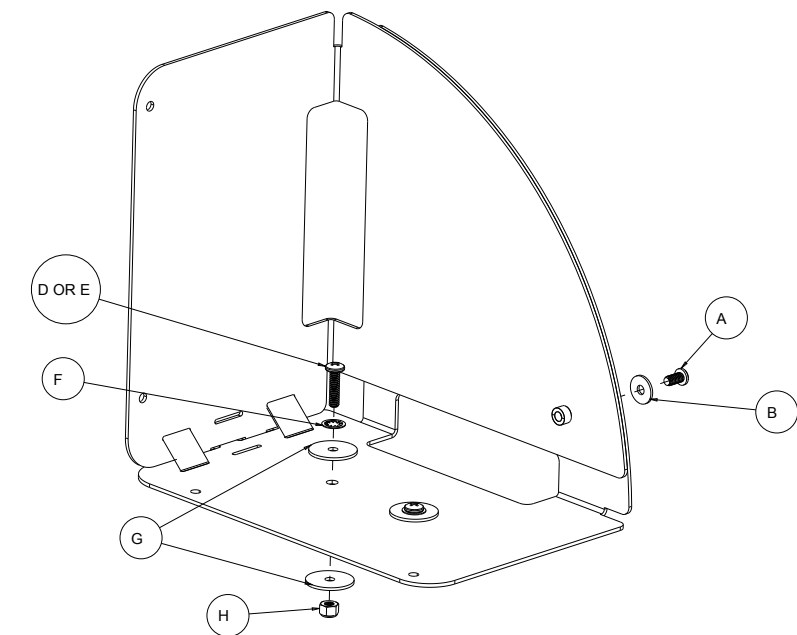

FIGURE 3: ANGLE ADJUSTMENT

