

The Endurance™ 'In Sync' Modular Series Sync Chair

Lounge & Group Seating Chair

Versatile, spacious chair intended for lounging. The Sync Chair can stand alone or be combined with any 'In Sync' Modular Series chair to create flexible arrangements that allow for change over time. The ergonomic design provides maximum comfort using rotational molding technology.



FEATURES:

- Rotationally molded design for increased strength. Constructed of high impact "no break" polyethylene. No steel or wood components
- Integral plinth base for increased stability and floor mounting integrity
- Can be bolted together in place, or to the floor via concealed pilot holes
- 1500 lb. Static Load, ANSI/BIFMA X5.1-2011
- Easy to clean, sanitize & maintain
- Can be easily filled with sandbags through optional ballast door on site to weigh down. Secures with tamper resistant screws
**Do not use loose sand*
- Passes Flammability UL 94 HB
- Tested to ISO 22196 showing a >99% reduction in bacteria
- Flame Retardant (passes Cal 133)
Test reports available upon request
- Manufactured to ISO Quality Standards in the USA 

**10 Year
Factory Warranty**

**33H x 29W x 32D
Seat Height 19**

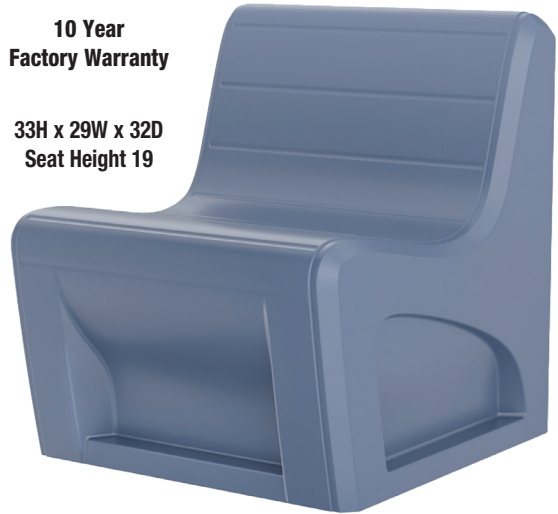

COLOR
Aqua
Black
Blue Gray
Brown
Burgundy
Gray
Green
Indigo
Midnight Blue
Sand
Slate Blue
Stone Gray

COLOR
Aqua with Access Door
Black with Access Door
Blue Gray with Access Door
Brown with Access Door
Burgundy with Access Door
Gray with Access Door
Green with Access Door
Indigo with Access Door
Midnight Blue with Access Door
Sand with Access Door
Slate Blue with Access Door
Stone Gray with Access Door

Available in



Aqua Black Blue Gray Brown Burgundy Gray Green Indigo Midnight Blue Sand Slate Blue Stone Gray

Custom colors available upon request. Call Cortech for details.

THE SYNC CHAIR

Endurance™ 'In Sync' Modular Series

OVERVIEW

The Sync Chair is a versatile, spacious chair intended for lounging, with the ability to stand alone or be bolted together with any Endurance™ 'In Sync' Modular Chair. The ergonomic design provides maximum comfort using rotational molding technology. **Manufactured to ISO Quality Standards in the USA.**

FABRICATION/MATERIAL

Durable, one piece, rotationally molded design for increased strength. Constructed with high impact "no break" polyethylene. Flame Retardant (as shown passes Cal 133). Test reports available upon request.

COLOR Aqua, Black, Blue Gray, Brown, Burgundy, Gray, Green, Indigo, Midnight Blue, Sand, Slate Blue, Stone Gray

WEIGHT 38 lbs.

OPTIONS Can be bolted to the floor via concealed pilot holes OR filled with sandbags through optional ballast door on site to weigh down. Hardware bit size: T27.

WARRANTY 10 Year Factory Warranty.

MAINTENANCE Easy to clean, sanitize & maintain.

STATIC LOAD +1000 lbs.

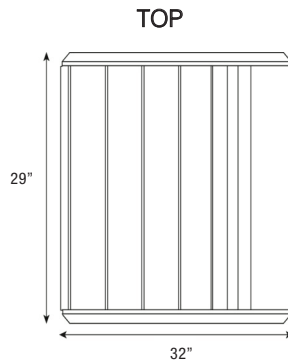
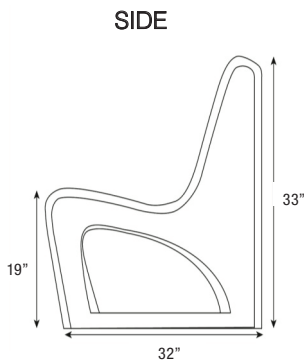
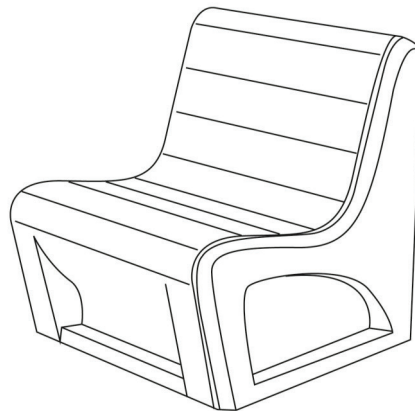

BACK w/ACCESS DOOR

