



Assembly Instructions

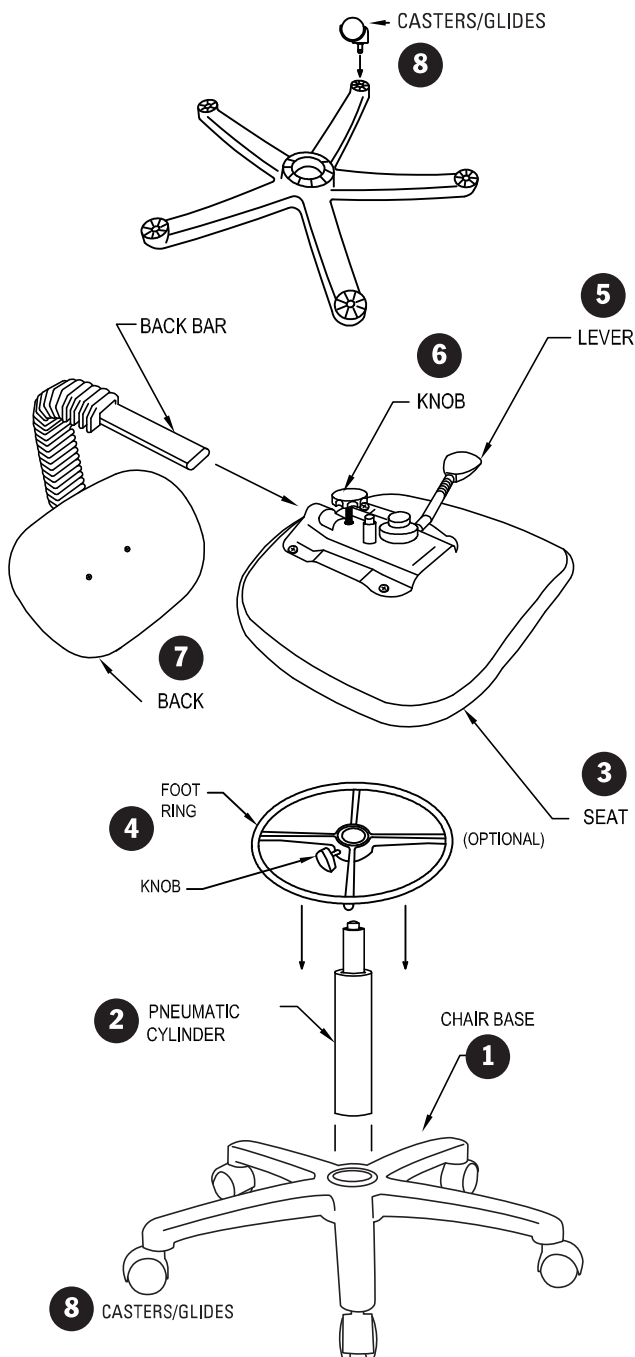

figure 1

- 1) Remove base, back/back bar, pneumatic cylinder, casters/glides, and seat from box.
- 2) Put casters or glides on base. Use pressure to push in (8).
- 3) Slide **optional** foot ring (4) over pneumatic cylinder from bottom (2) about halfway up the cylinder and tighten knob (7).
- 4) Place base with legs on hard level surface (1).
- 5) Insert pneumatic cylinder as shown in (2) into center hole of base and lightly push down. Adjust foot ring to desired height.
- 6) Turn seat upside down to assemble back. It may be helpful to lay the seat on the edge of a table to slide the back bar into position.
- 7) Loosen knob (6) counter clockwise slightly to allow the back bar to slide into the control mechanism on the seat. Push in until you hear it click. Then tighten by turning knob (6) clockwise, do not overtighten.
- 8) Turn seat and back over and align the center hole on the bottom of the seat with the top of the pneumatic cylinder and lightly push down. With the weight of your body, carefully sit on the seat. This will press the base, pneumatic cylinder, and seat together.
- 9) To raise the height of your chair simply pull up on lever (5) while not seated.
- 10) To lower the height of your chair, while seated on chair, pull up on lever (5).

In/Out and Up/Down back adjustments not available on all options.



Assembly Instructions

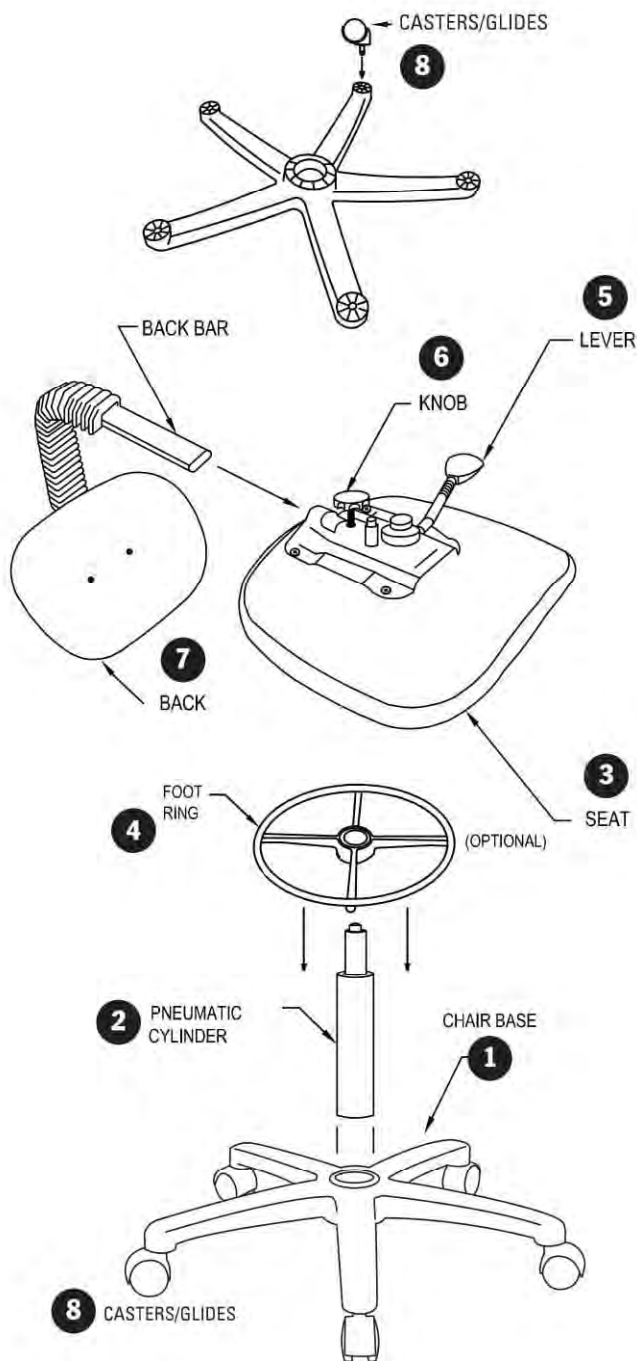

figure 1

- 1) Remove base, back/back bar, pneumatic cylinder, casters/glides, and seat from box.
- 2) Put casters or glides on base. Use pressure to push in (8).
- 3) Slide **optional** foot ring (4) over pneumatic cylinder from bottom (2) about halfway up the cylinder
- 4) Place base with legs on hard level surface (1).
- 5) Insert pneumatic cylinder as shown in (2) into center hole of base and lightly push down. Adjust foot ring to desired height.
- 6) Turn seat upside down to assemble back. It may be helpful to lay the seat on the edge of a table to slide the back bar into position.
- 7) Loosen knob (6) counter clockwise slightly to allow the back bar to slide into the control mechanism on the seat. Push in until you hear it click. Then tighten by turning knob (6) clockwise, do not overtighten.
- 8) Turn seat and back over and align the center hole on the bottom of the seat with the top of the pneumatic cylinder and lightly push down. With the weight of your body, carefully sit on the seat. This will press the base, pneumatic cylinder, and seat together.
- 9) To raise the height of your chair simply pull up on lever (5) while not seated.
- 10) To lower the height of your chair, while seated on chair, pull up on lever (5).

In/Out and Up/Down back adjustments not available on all options.



Assembly Instructions

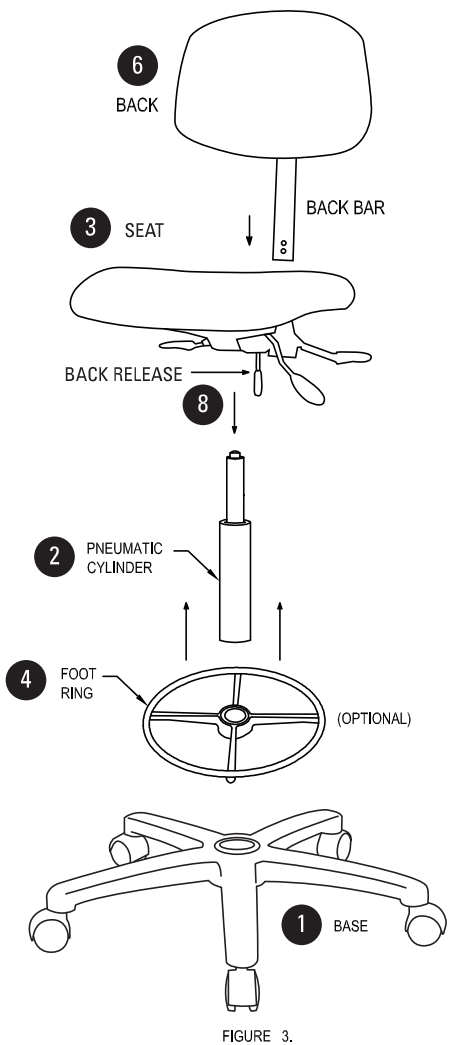
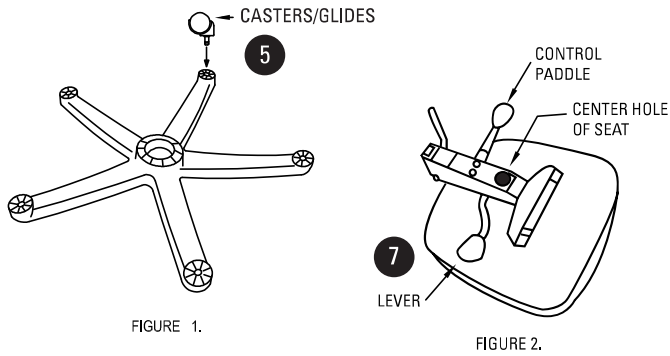

- 1) Remove base, back/back bar, pneumatic cylinder, seat, foot ring (if included) and casters/glides from box.
- 2) Place base (1) upside down and insert casters/glides (5) (see figure 1).
- 3) Slide **optional** foot ring (4) over bottom pneumatic cylinder (2). The foot ring rests atop spokes. Make sure spokes face the floor.
- 4) Flip the base so casters/glides are on the floor and insert pneumatic cylinder (2) as shown in (figure 3) into center hole of base with colored button up. Lightly push down. Adjust foot ring to desired height.
- 5) Align the center hole of the underside of the seat assembly (3) with the top of the pneumatic cylinder (2) and lightly push down. Kneel on the seat to hold it together. This will press the base, pneumatic cylinder and seat together. (Underside of the seat is shown in Figure 2)
- 6) Lift the back release. Insert back bar through the control channel slot. Adjust the height of the seat back for comfort and push the back release lever down to lock the bar in place. Once locked, push the enclosed safety button into the lower hole of back bar, flat side out.
- 8) Adjust the seat back to the desired angle using the control lever located on the side of the seat. You can adjust the height of the back by lifting the back release up. Push the back release(8) down to lock the bar in place.
- 9) To raise the height of your chair, take your weight off of the chair and pull up on the lever (7) on the underside of the seat and adjust.
- 10) To lower the height of your chair you must be seated with your weight on the seat, lift up on lever (7).



Assembly Instructions

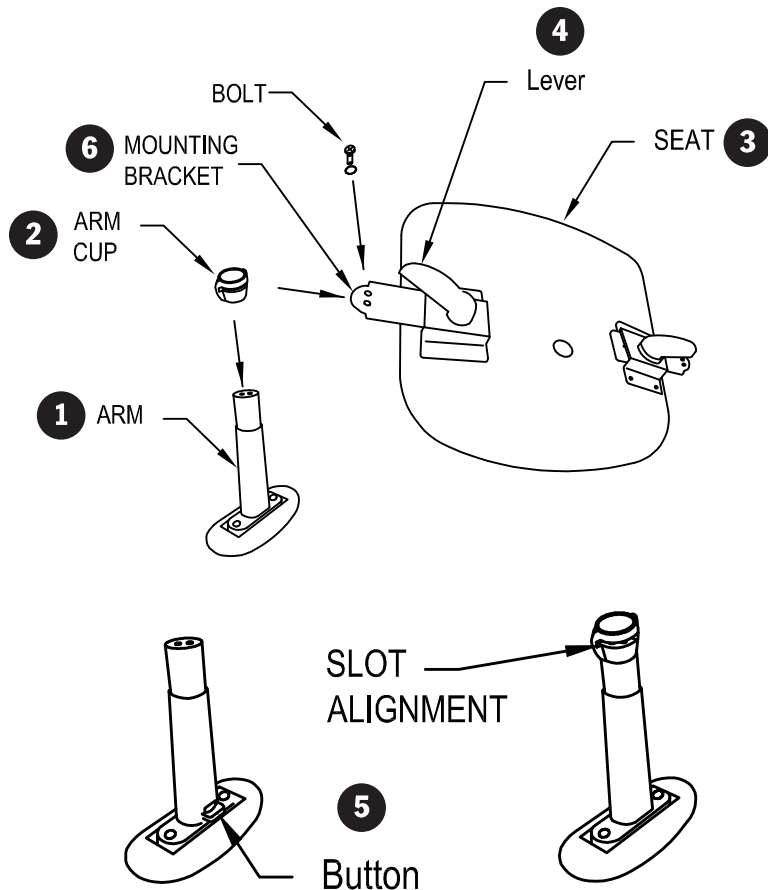

- 1) Remove the two bolts from the (1) arm.
- 2) Align the open slot of the (2) arm cup so that it is even with the bottom of the cylinder of (1) arm.
- 3) With the (3) seat upside down, align the slot of the (2) arm cup with the (6) mounting bracket. Attach with the two bolts. (Note: Make sure that the (5) button is facing away from the (3) seat.) Repeat steps for opposite side.
- 4) You can adjust the arms in and out by loosening (4) lever and sliding the arm in or out. When adjusted to desired location, tighten (4) lever.
- 5) You can adjust the arms up or down by pulling up on (5) button, adjust to desired height and then release (5) button.



Assembly Instructions

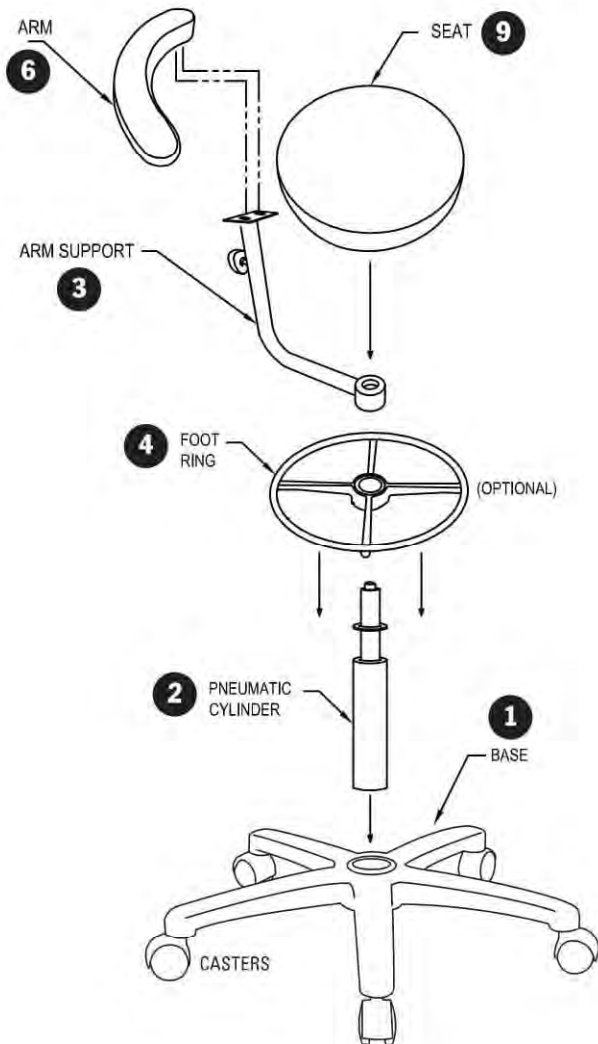
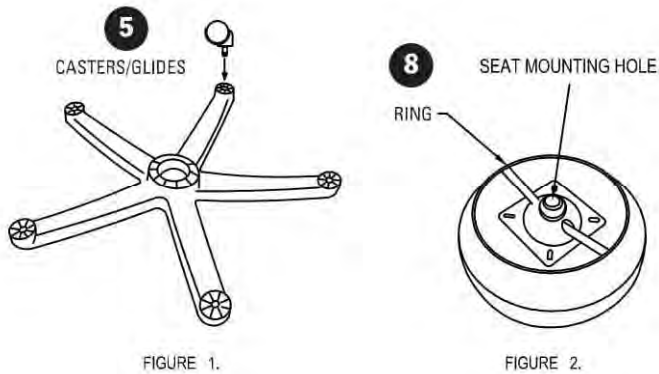

- 1) Remove arm, base, pneumatic cylinder, seat, foot ring (optional), and casters/glides from box.
- 2) Place base (1) upside down and insert casters/glides (5) (see figure 1). Flip base over once casters/glides have been inserted.
- 3) Slide **optional** foot ring (4) over pneumatic cylinder from bottom (2) about halfway up the cylinder
- 4) Insert pneumatic cylinder (2) as shown in (figure 3) into center hole of base with colored button up and lightly push down. Adjust foot ring to desired height
- 5) Align the two holes on the bottom of (6) arm with the two holes on the bracket on (3) arm support and secure with the two shoulder bolts and washers supplied. (Note: There are two holes on both ends of (3) arm for the option of either being on the right side or left side)
- 6) Align center hole of (3) arm support with (2) pneumatic cylinder and slide down.
- 7) Align the center hole of seat (3) on the bottom of the seat (see figure 2) with the top of the pneumatic cylinder (2) and lightly push down. With the weight of your body, carefully sit on the seat. This will press the base, pneumatic cylinder, and seat together.
- 8) To raise the height of your chair simply pull up on ring (8) while not seated.
- 9) To lower the height of your chair, while seated on chair, pull up on ring (8).

Note: 2mm allen wrench to adjust pneumatic cylinder ring.



Assembly Instructions

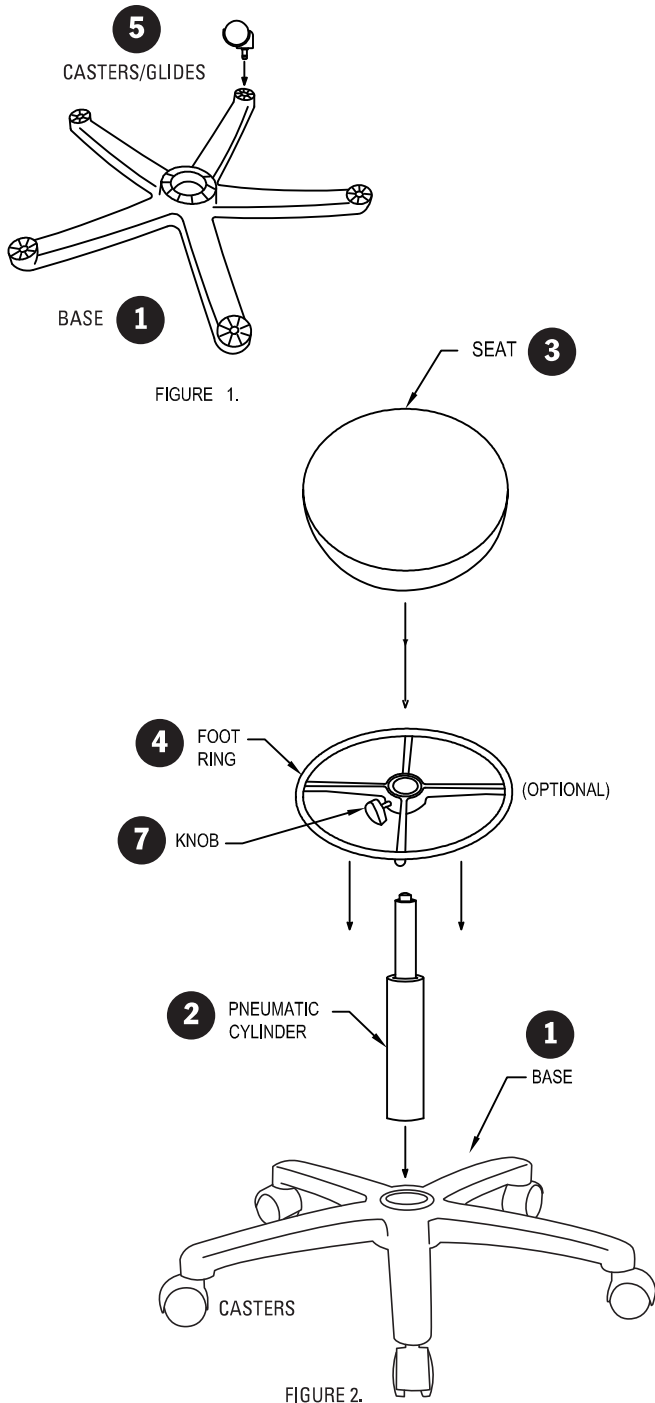

- 1) Remove base, pneumatic cylinder, seat, foot ring (if included) and caster/glides from box.
- 2) Place base (1) upside down and insert casters/glides (5) (see figure 1).
- 3) Slide **optional** foot ring (4) over pneumatic cylinder from bottom (2) about halfway up the cylinder and tighten knob (7).
- 4) Flip the base so casters/glides are on the floor and insert pneumatic cylinder (2) as shown in (figure 2) into center hole of base with colored button up. Lightly push down. Adjust foot ring to desired height
- 5) Align the center hole of the underside of the seat assembly (3) with the top of the pneumatic cylinder (2) and lightly push down. With the weight of your body carefully sit on the seat. This will press the base, pneumatic cylinder, and seat together.
- 6) To raise the height of your stool, take your weight off of the stool and pull on the ring on the underside of the seat and adjust.
- 7) To lower the height of your stool you must be seated with your weight on the seat - lift up on the ring.



Assembly Instructions

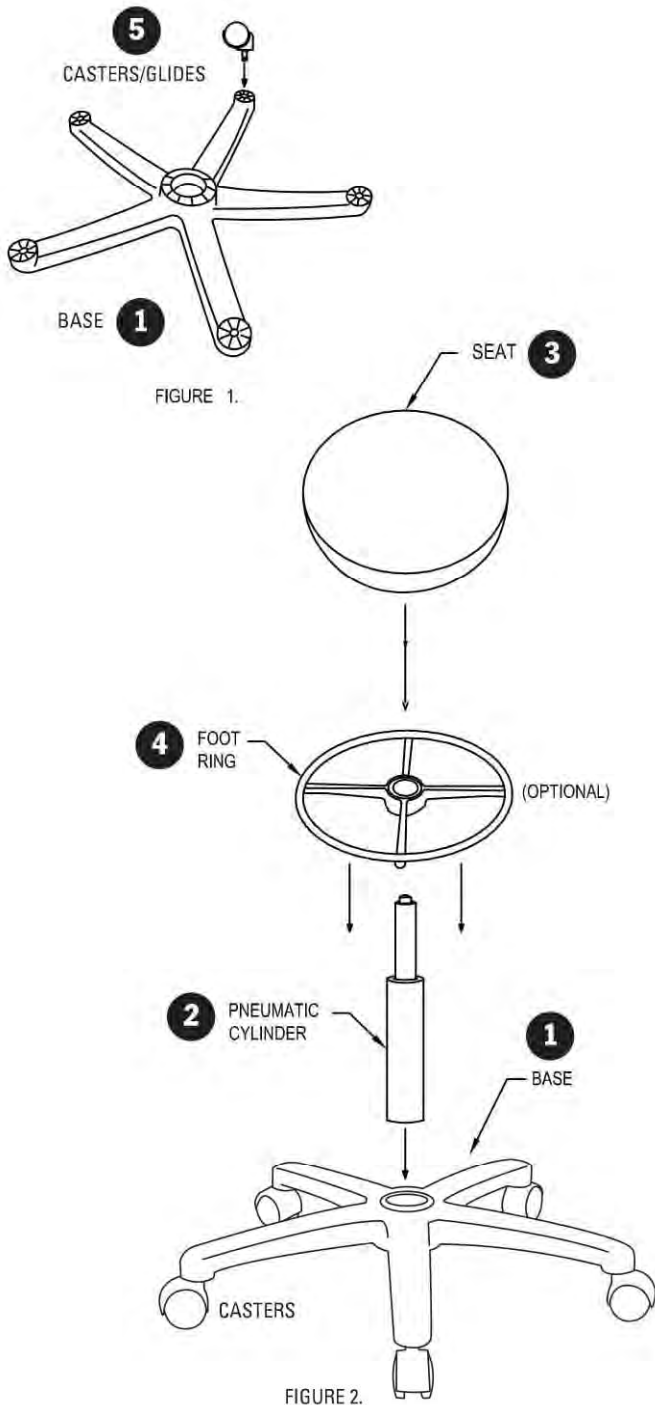

- 1) Remove base, pneumatic cylinder, seat, foot ring (if included) and caster/glides from box.
- 2) Place base (1) upside down and insert casters/glides (5) (see figure 1).
- 3) Slide **optional** foot ring (4) over pneumatic cylinder from bottom (2) about halfway up the cylinder
- 4) Flip the base so casters/glides are on the floor and insert pneumatic cylinder (2) as shown in (figure 2) into center hole of base with colored button up. Lightly push down. Adjust foot ring to desired height
- 5) Align the center hole of the underside of the seat assembly (3) with the top of the pneumatic cylinder (2) and lightly push down. With the weight of your body carefully sit on the seat. This will press the base, pneumatic cylinder, and seat together.
- 6) To raise the height of your stool, take your weight off of the stool and pull on the ring on the underside of the seat and adjust.
- 7) To lower the height of your stool you must be seated with your weight on the seat - lift up on the ring.



Assembly Instructions

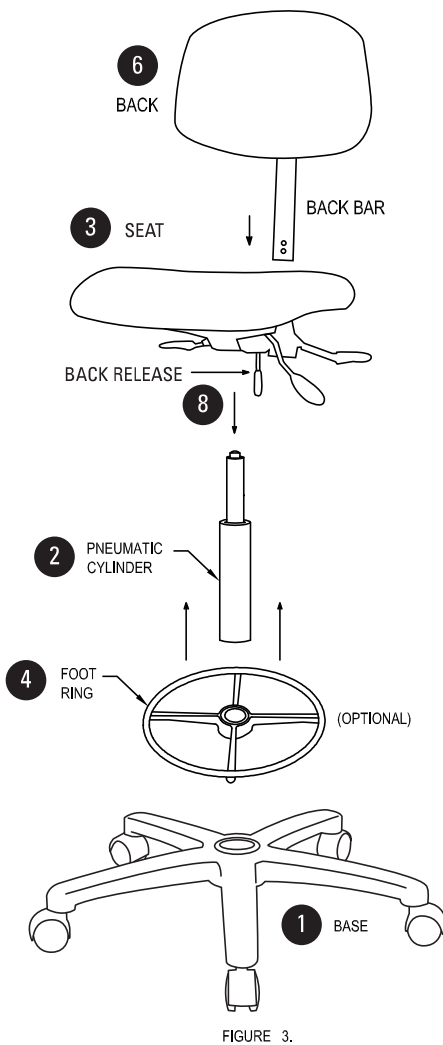
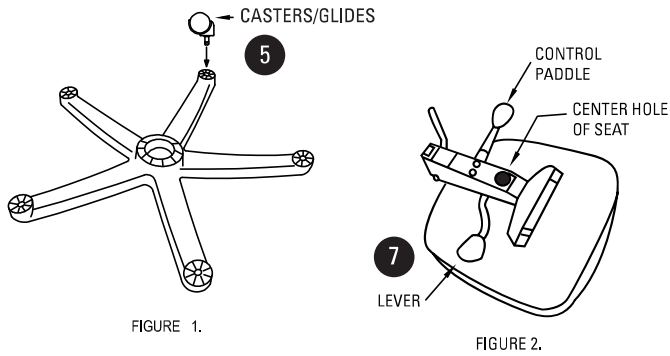

- 1) Remove base, back/back bar, pneumatic cylinder, seat, foot ring (if included) and casters/glides from box.
- 2) Place base (1) upside down and insert casters/glides (5) (see figure 1).
- 3) Slide optional foot ring (4) over bottom pneumatic cylinder (2). The foot ring rests atop spokes. Make sure spokes face the floor.
- 4) Flip the base so casters/glides are on the floor and insert pneumatic cylinder (2) as shown in (figure 3) into center hole of base with colored button up. Lightly push down. Adjust foot ring to desired height.
- 5) Align the center hole of the underside of the seat assembly (3) with the top of the pneumatic cylinder (2) and lightly push down. Kneel on the seat to hold it together. This will press the base, pneumatic cylinder and seat together. (Underside of the seat is shown in Figure 2)
- 6) Remove the bolt from the bottom hole of the back bar. Lift the back release. Insert back bar through the control channel slot. Adjust the height of the seat back for comfort and push the back release lever down to lock the bar in place. Once locked, push the enclosed safety button into the upper hold of the back bar, flat side out.
- 7) Slide the grounding wire eyelet around the removed screw and reattach the screw to the lower hole of the back bar with the head of the screw on the underside of the back bar.
- 8) Adjust the seat back to the desired angle using the control lever located on the side of the seat. You can adjust the height of the back by lifting the back release up. Push the back release(8) down to lock the bar in place.
- 9) To raise the height of your chair, take your weight off of the chair and pull up on the lever (7) on the underside of the seat and adjust.
- 10) To lower the height of your chair you must be seated with



Oxford Series Assembly Instructions

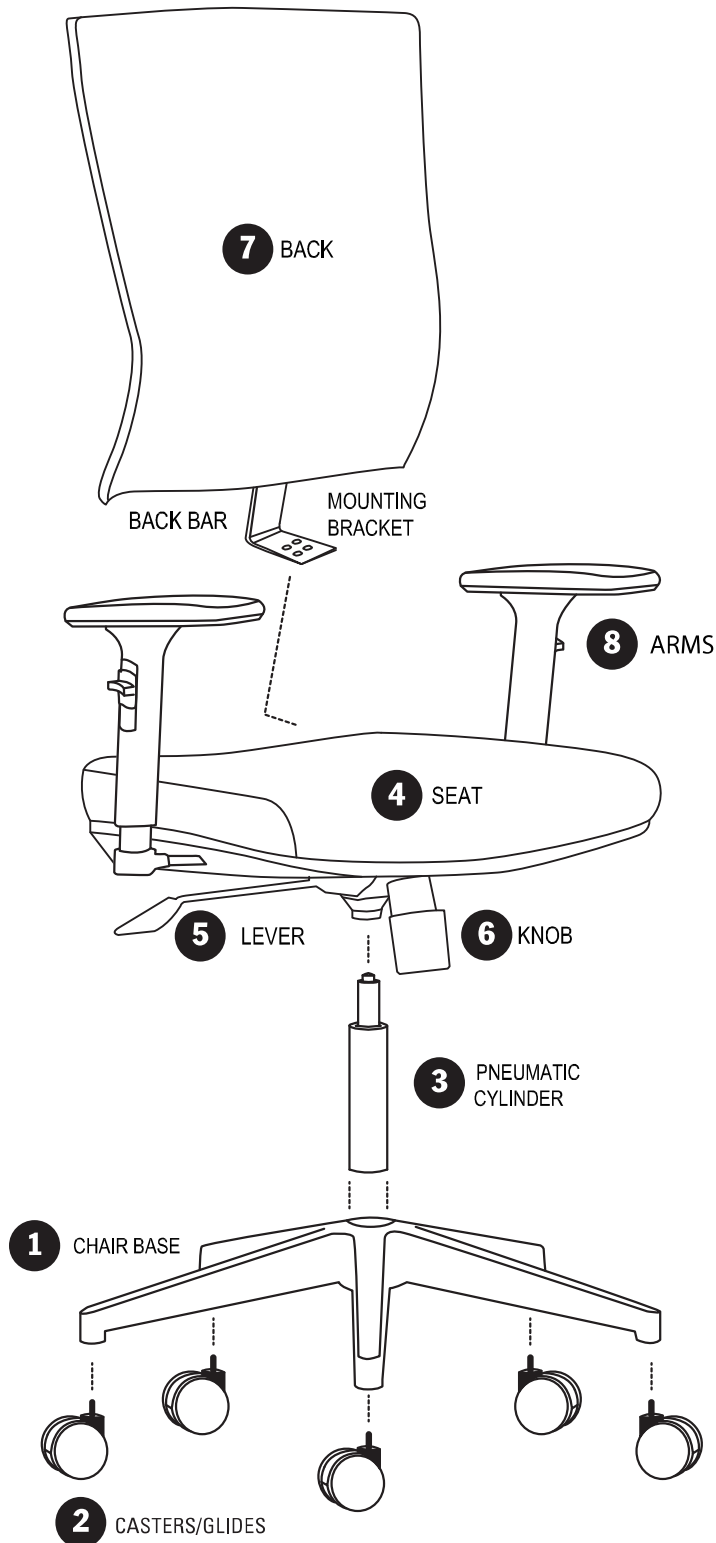

- 1) Remove base, back, pneumatic cylinder, casters/glides, and seat from box.
- 2) Insert casters/glides **2** on base **1**. Using pressure, push the casters/glides into the base making sure they are all the way in.
- 3) Place base **1** with legs on hard level surface.
- 4) Insert cylinder **3** into center hole of base and lightly push down.
- 5) (Optional) Arm rests **8** are factory installed for shipping. Use enclosed allen wrench to adjust width of arms: loosen screw, adjust arms, tighten screw.
- 6) Turn seat upside down and place on the edge of a table to slide the back bar into position.
- 7) Attach back bar to seat **4** using 4 bolts and 4 washers. Firmly tighten with enclosed allen wrench.
- 8) Turn assembled seat over and align the center hole on the bottom of the seat with the top of the pneumatic cylinder and lightly push down. With the weight of your body, carefully sit on the seat. This will press the base, pneumatic cylinder, and seat together.



Windrowe Series Assembly Instructions

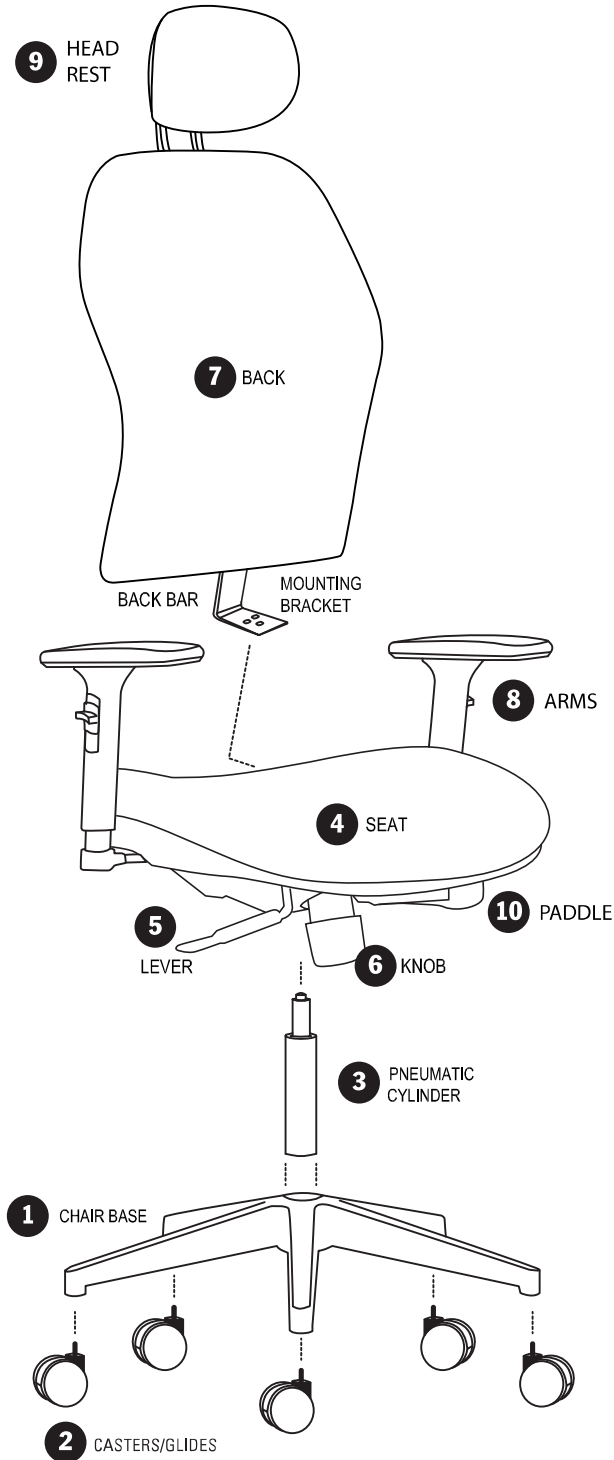

- 1) Remove base, back, pneumatic cylinder, casters/glides, and seat from box.
- 2) Insert casters/glides **2** on base **1**. Using pressure, push the casters/glides into the base making sure they are all the way in.
- 3) Place base **1** with legs on hard level surface.
- 4) Insert cylinder **3** into center hole of base and lightly push down.
- 5) (Optional) Arm rests **8** are factory installed for shipping. Use enclosed allen wrench to adjust width of arms: loosen screw, adjust arms, tighten screw.
- 6) Turn seat upside down and place on the edge of a table to slide the back bar into position.
- 7) Attach back bar to seat **4** using 3 bolts and 3 washers. Firmly tighten with enclosed allen wrench.
- 8) (Optional) Attach headrest **9** to top of seat back **7** and using enclosed allen wrench, insert and tighten 2 screws to back.
- 9) Turn assembled seat over and align the center hole on the bottom of the seat with the top of the pneumatic cylinder and lightly push down. With the weight of your body, carefully sit on the seat. This will press the base, pneumatic cylinder, and seat together.

To Adjust The Foot Ring Height

***** Initial Installation must be completed from the bottom of the cylinder *****

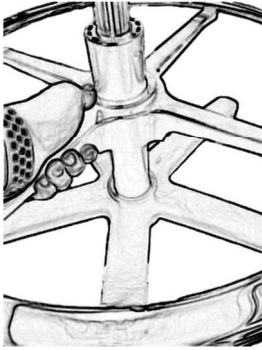

Unlock the foot ring by pushing the top of the inner center hub down.

Adjust the height to the appropriate height.

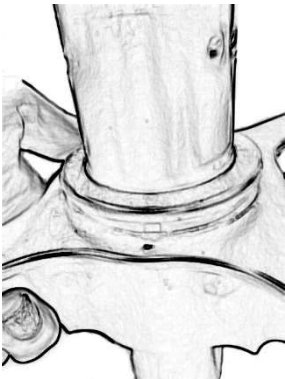

Lock the foot ring in place by pushing on the spokes until the inner center hub extends approximately ½" from the outer center hub.

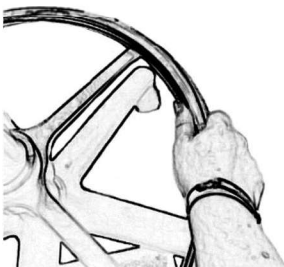

To fully lock, put pressure alternatively on the outer ring sides.