



**S961 Total Hip
Owner's Manual**



SportsArt

S961 OWNER'S MANUAL CONTENTS

1. INTRODUCTION	2
2. SAFETY PRECAUTIONS	3
3. LIST OF PARTS	4
4. ASSEMBLE THE PRODUCT	6
STEP 1 Install the Rear Covers.....	6
STEP 2 Install the Main Frame	7
STEP 3 Install the Handles	8
STEP 4 Install the Leg Cushion	9
STEP 5 Install the Foot Covers	10
STEP 6 Install the Storage Tray Holder	11
STEP 7 Minor Weight Stack Instructions	12
STEP 8 Belt Tension Adjustment Instructions	13
5. OPERATE THE PRODUCT	14
OPERATION Operate the Product	14
6. MAINTENANCE	15
MAINTENANCE Machine Maintenance	15
MAINTENANCE Schedule	17
MAINTENANCE Task List	18
MAINTENANCE One-Year Maintenance Log	19
7. CONSIGNES DE SÉCURITÉ IMPORTANTES	20

1. INTRODUCTION

Congratulations on the purchase of a high quality SportsArt product, the S961 Total Hip machine. Constructed of high quality materials and designed for years of reliable performance, this product was made for full commercial use.

Before this product is assembled or operated, we recommend that you familiarize yourself with this manual. Understanding the correct assembly and operation of this product will help ensure that exercisers obtain their fitness goals safely and successfully.

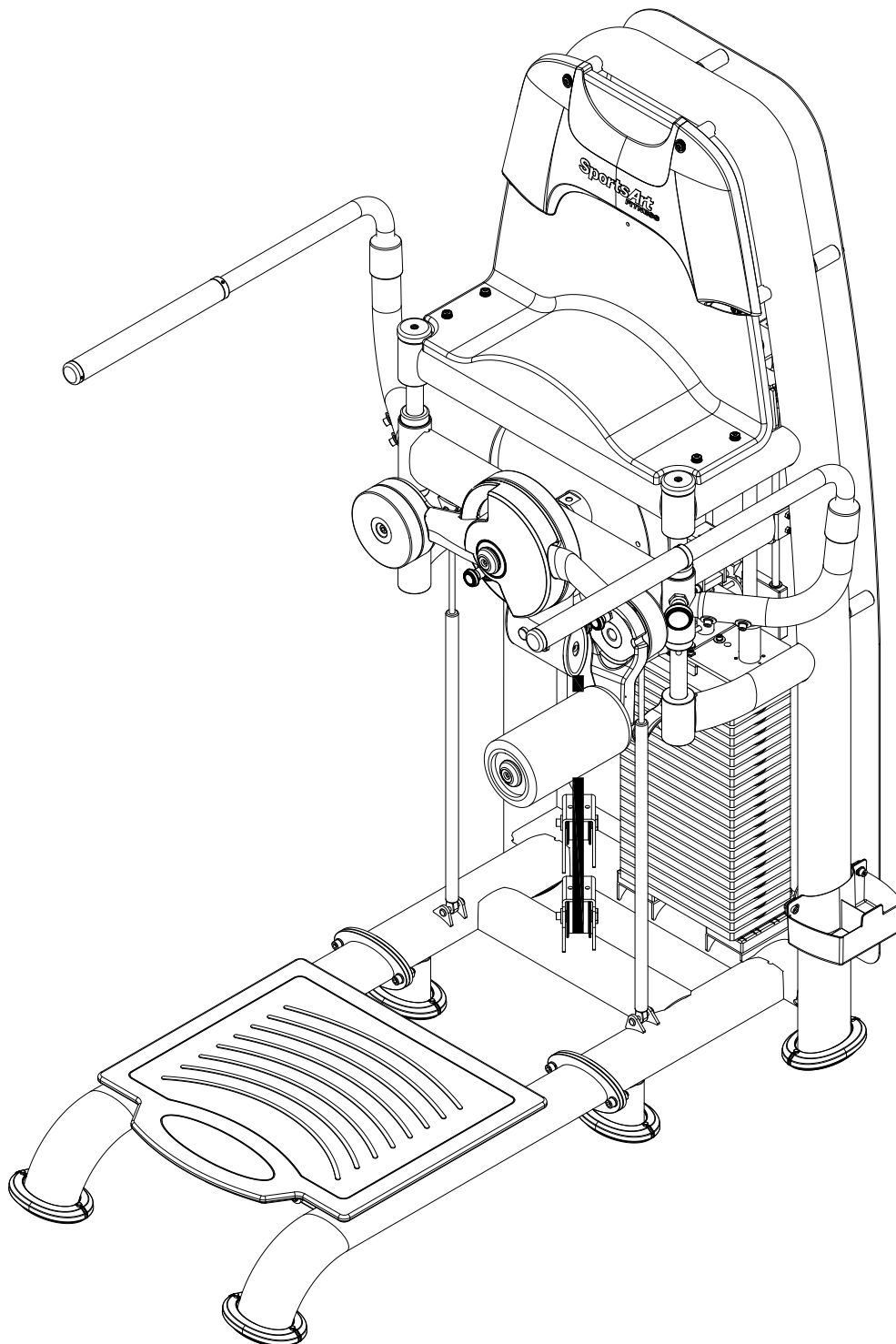

2. SAFETY PRECAUTIONS

This product was designed and built for optimum safety. However certain precautions apply during the use of this product. Please note the following safety precautions:

- Please read the entire manual before assembly and operation. Make sure the product is installed and operated as instructed in this manual.
- Assemble and operate the product on a solid, level surface. Do not use outdoors or near water, including pools and saunas.
- Check the product before every use. Make sure all parts are assembled, and all fasteners are tightened. Do not use the product if it is disassembled in any way.
- Wear proper workout clothing. Do not wear loose clothing. Do not wear shoes with leather soles or high heels. Tie all long hair back. Do not go barefoot on this product.
- Keep away from moving parts. Moving parts may or may not stop immediately if an object becomes caught or impedes normal motion.
- Use this product only for its intended purpose as described in this manual.
- Be careful when mounting and dismounting the unit.
- Never operate this product if it has been damaged in any way. If it is not working properly, or has been dropped or damaged, contact a service technician for repairs.
- Do not use accessories that are not specifically recommended by the manufacturer. Such parts might cause injuries or cause the unit to fail.
- This product is not intended for use by persons (including children) with reduced physical, sensory, or mental capabilities, or by people who are otherwise deficient in product knowledge or experience. If such people use this product, they should be given training and be supervised at all times by someone responsible for their safety.
- Children should be supervised to ensure that they do not play on or near the product.
- The user weight limit for this product is 227 kg, 500 lb.

CAUTION: If you feel any pain or any abnormal sensations, STOP YOUR WORKOUT and consult your physician immediately. Work within your recommended exercise level. DO NOT work to exhaustion. Before beginning any exercise program, you should consult with your doctor. It is recommended that you undergo a complete physical examination.

*NOTE: Regarding the decaled resistance on the unit weight stack, the actual weight being lifted is configured at a ratio of 5:1. Example: If the stack fork is engaged at 60KG (132LB) at the weight stack, the actual pulling weight is 12KG (26LB).

3. LIST OF PARTS

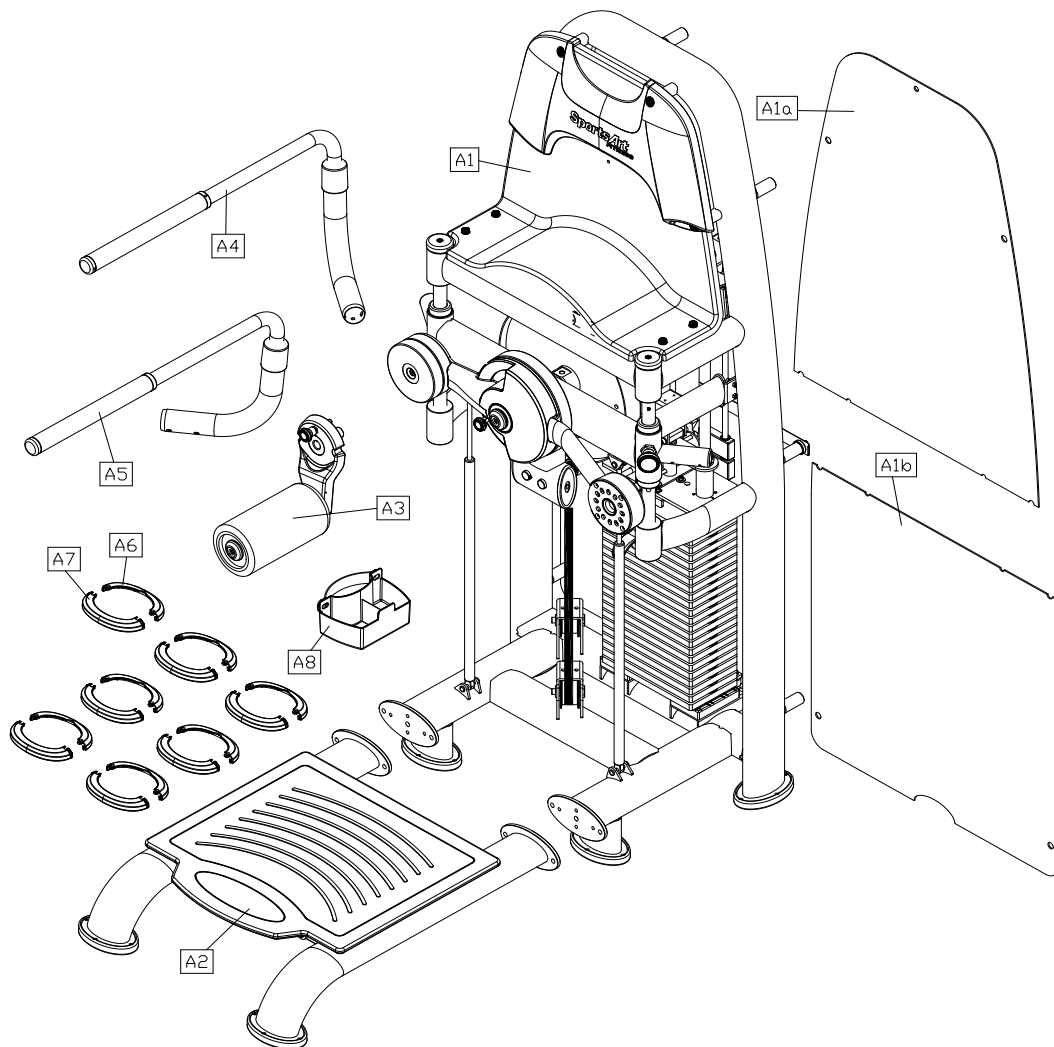

Assembly Parts					
No.	Name	Qty.	No.	Name	Qty.
A1	Weight Stack Frame	1	A4	Left Handle	1
A1a	Rear Cover, Top	1	A5	Right Handle	1
A1b	Rear Cover, Bottom	1	A6	118 Oval Foot Cover A	7
A2	Support Frame	1	A7	118 Oval Foot Cover B	7
A3	Leg Cushion	1	A8	Storage Tray	1

Components in the Hardware Kit				
No.	Name	Qty.	Specification	Notes
10	Cover cap	1	D23*t8.8	
11	Push revits	14		
	L-shaped Allen wrench	1	M5	
	L-shaped Allen wrench	1	M6	
	Double open-end wrench	1	8*17	
	Double open-end wrench	1	8*10	
	Double open-end wrench	1	13.2*15.2	
	Double open-end wrench	1	17*23	

Components on the Product				
No.	Name	Specification	Notes	
20	Hex screws	M10*P1.5*L35		
	Spring washer	M10		
	Washer	D16*d10.2*t1.0		
	Nylon hex nut	M10		
21	Round head hex screws	M8*P1.25*L15		
	Spring washer	M8		
	Handrail washer	D24*d8.3*t2.0		
22	Round head hex screws	M8*P1.25*L20		
	Flat washer	D40*d8.5*t3.0		
23	Cage fix plate	(With Foam)		
	Round head hex screws	M8*P1.25*L15		
	Flat washer	D17*d8.3*t2		
	Nylon hex nut	M8		
24	Plastic round head hex screws	M6*P1.0*35		
	Bushings	D21.5*10.5		

4. ASSEMBLE THE PRODUCT

Follow instructions below to assemble this product. Note that in this manual the words “left” and “right” are used to refer to the product and its parts. As such, these designations correspond to the “left” and “right” sides of a person in position to exercise on this product. Also, for brevity, the word “screws” or “nuts” is used where washers and other hardware may be involved.

STEP 1 Install the Rear Covers

- Please remove screws (24) from the area A.
- First align the Top Rear Cover (A1a) cut out with the B & C area screws. Afterwards align the screw holes on top, then tighten it with screws (24). (Note: the cover needs to be in between B area mounting columns; C area washers and the mounting plate.)
- Repeat the process for Bottom Rear Cover (A1b) with aligning the cut out to the B & C area screws. Afterwards, align the screw holes on the bottom, then tighten them with screws (24). Finally tighten the screws in the area B and nuts in the area C.

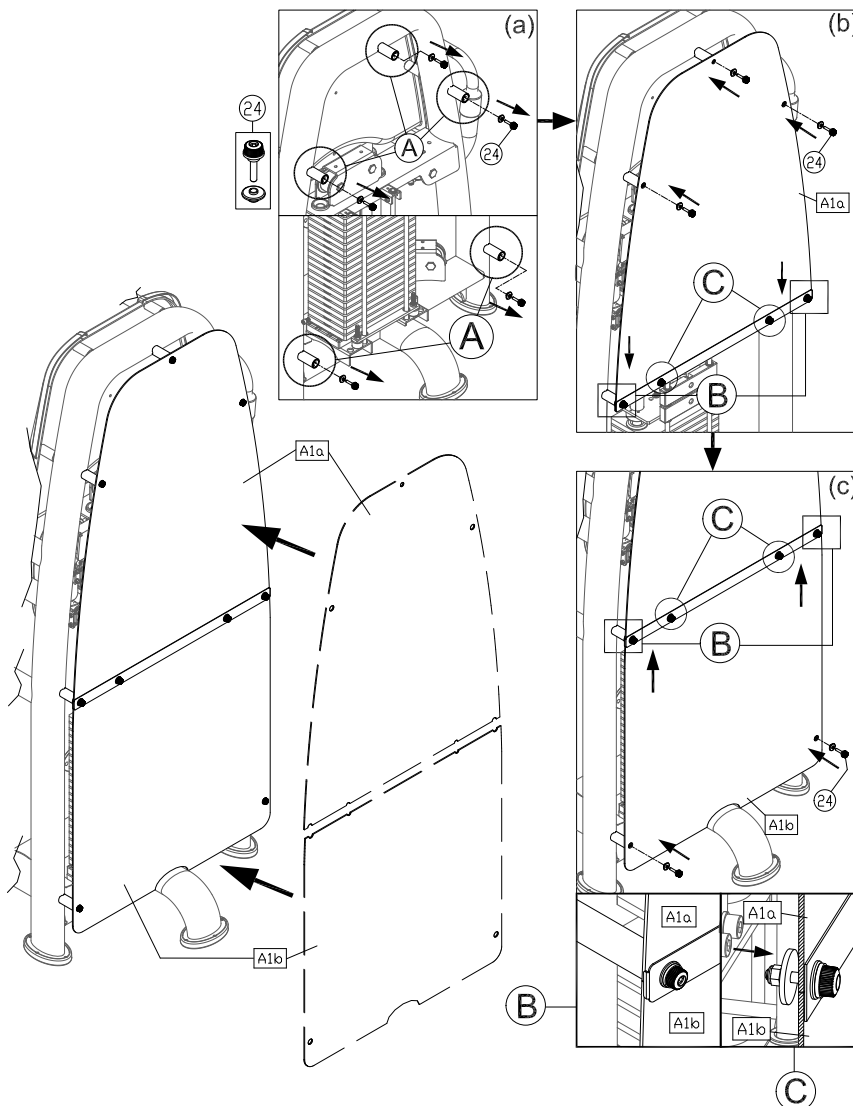

STEP 2 Install the Main Frame

When assembling the main frames, please have at least three people to assemble due to safety reasons.

(a). Please remove screws (20) from the weight stack frame (A1) and the support frame (A2).

(b). With one person holding the weight stack frame up, connect the support frame (A2) to the weight stack frame (A1), and use screws (20) to secure the assembly.

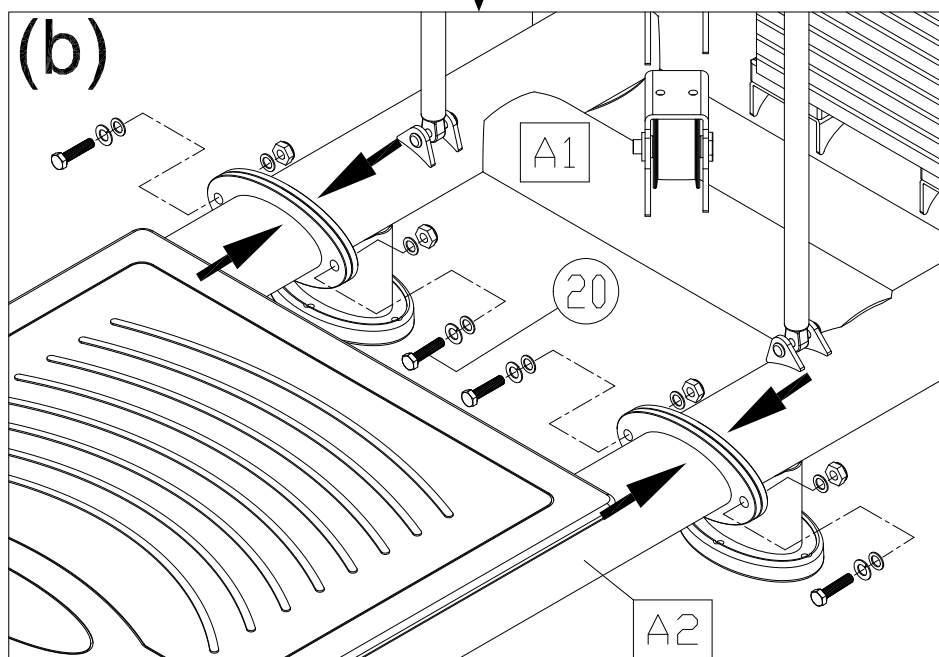
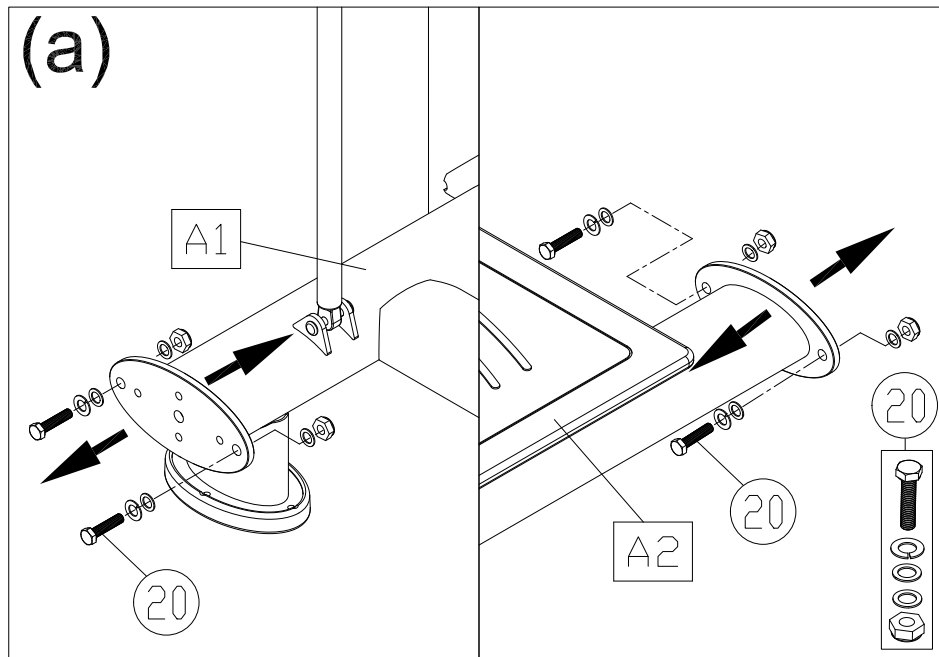

STEP 3 Install the Handles

- (a). Remove screws (21) from the weight stack frame (A1).
- (b). Attach the both left and right handles (A4)(A5) onto the weight stack frame (A1), then use screws (21) to secure the assembly.

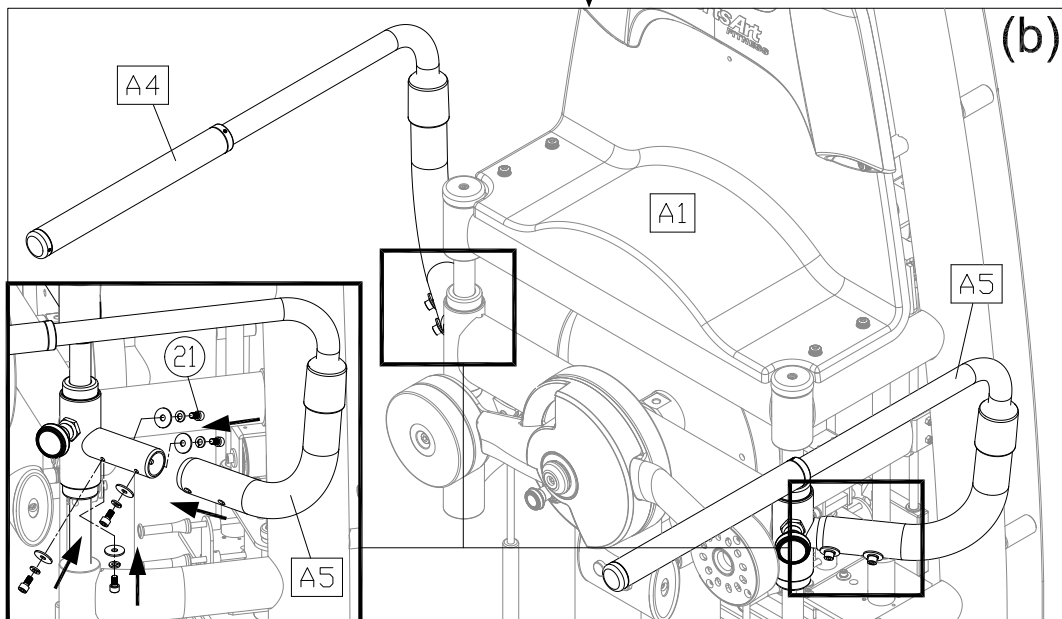
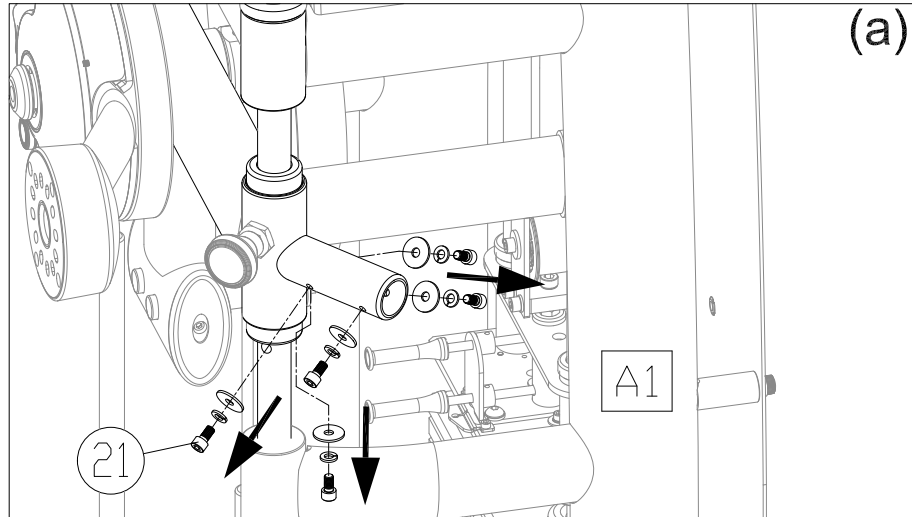

STEP 4 Install the Leg Cushion

(a). Remove the screws (22) from the leg cushion (A3).

(b). Shown below, connect the rotational connector of the leg cushion (A3) to the weight stack frame (A1). Use screws (22) to secure the assembly and then cover it with cork cover (10).

Note: When installing the back cushion, make sure the rotational connector is align with 4th hole before securing the assembly.

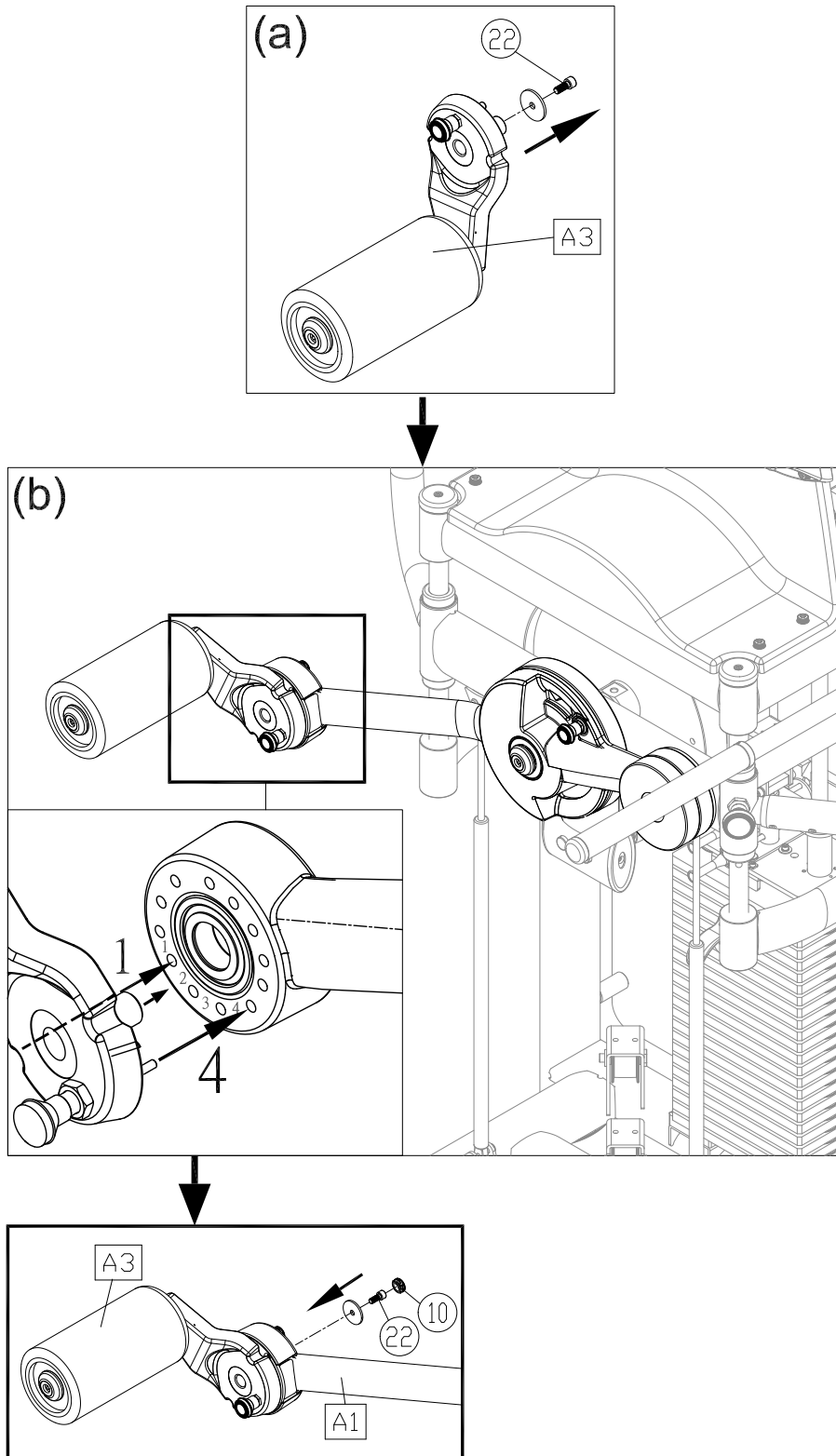

STEP 5 Install the Foot Covers

(a). Attach the oval foot covers (A6)(A7) onto the weight stack frame (A1) and the support frame (A2). Align the ends before using the push rivets (10) to secure the foot covers together.

Note: While installing the weight stack covers, if it can not be put together due to the Interference of the machine, please swap the direction of the covers.

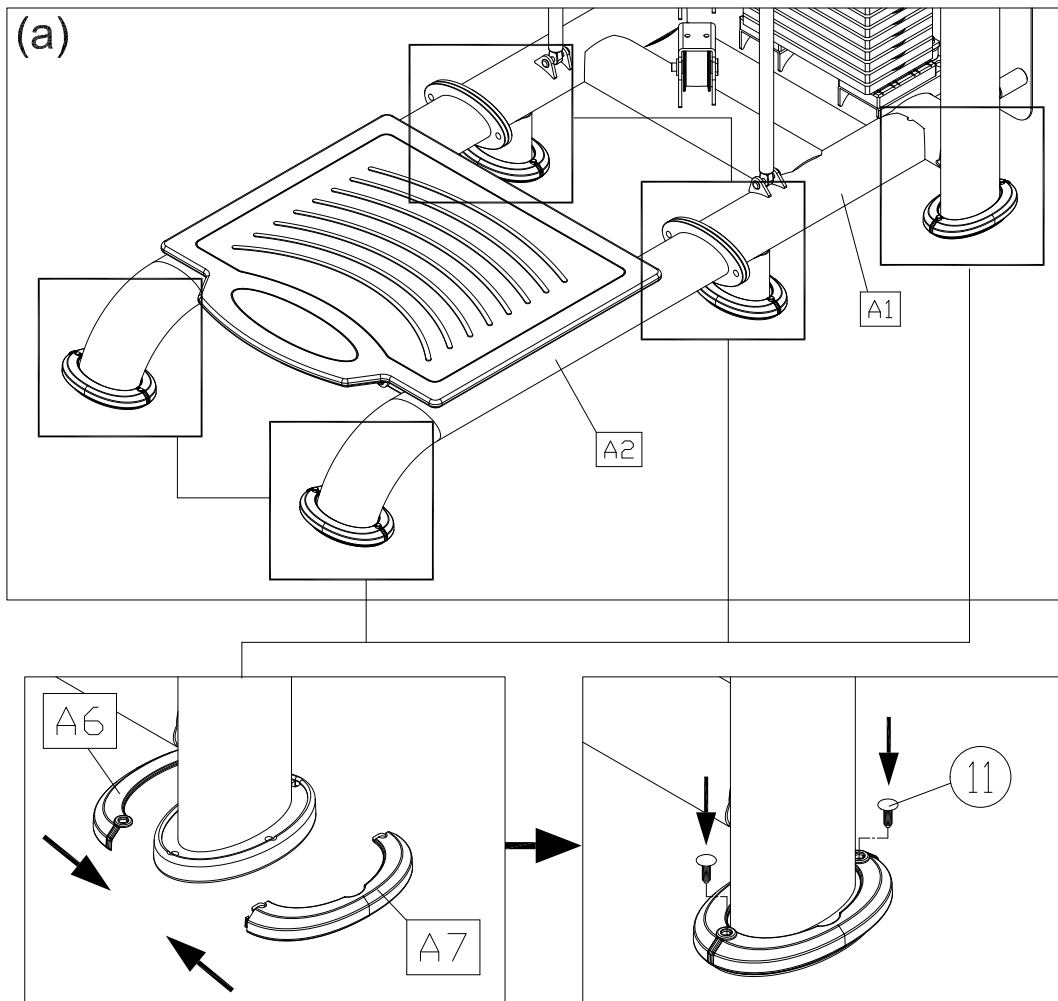

STEP 6 Install the Storage Tray Holder

Please follow the instructions (a) through (b) to install the storage tray

(a). Locate the position where the storage tray (A8) attaches to the weight stack frame (A1), then remove the screws (23) from the weight stack frame.

(b). Attach the storage tray (A8) to the weight stack frame (A1) and use screws (23) to secure the assembly.

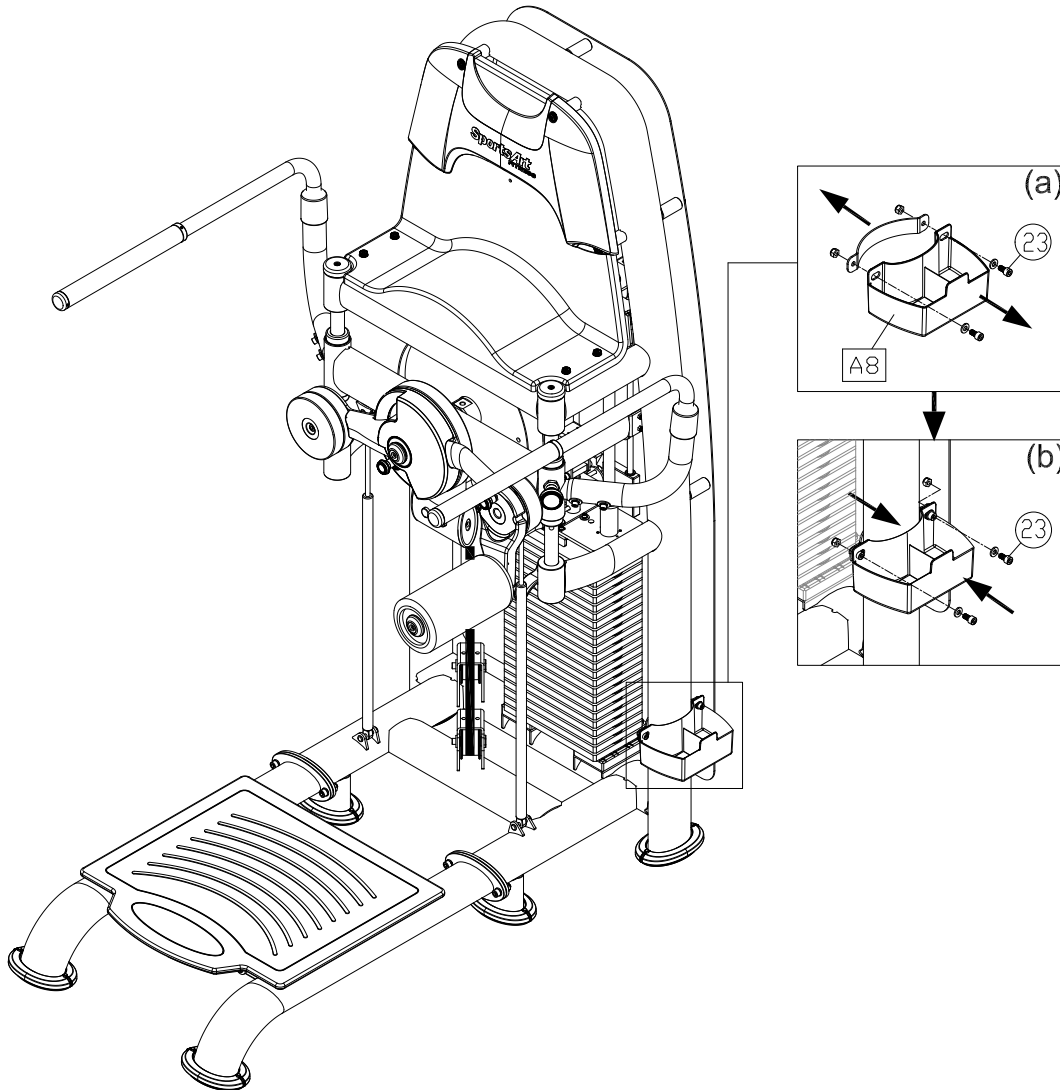

STEP 7 Minor Weight Stack Instructions

To adjust the minor weight stack, insert the upper pin to add 3.5Lbs/1.5kgs or the lower pin to add 6.5Lbs/3kgs. When the minor weights are not in use, pull the pin to release the weight.

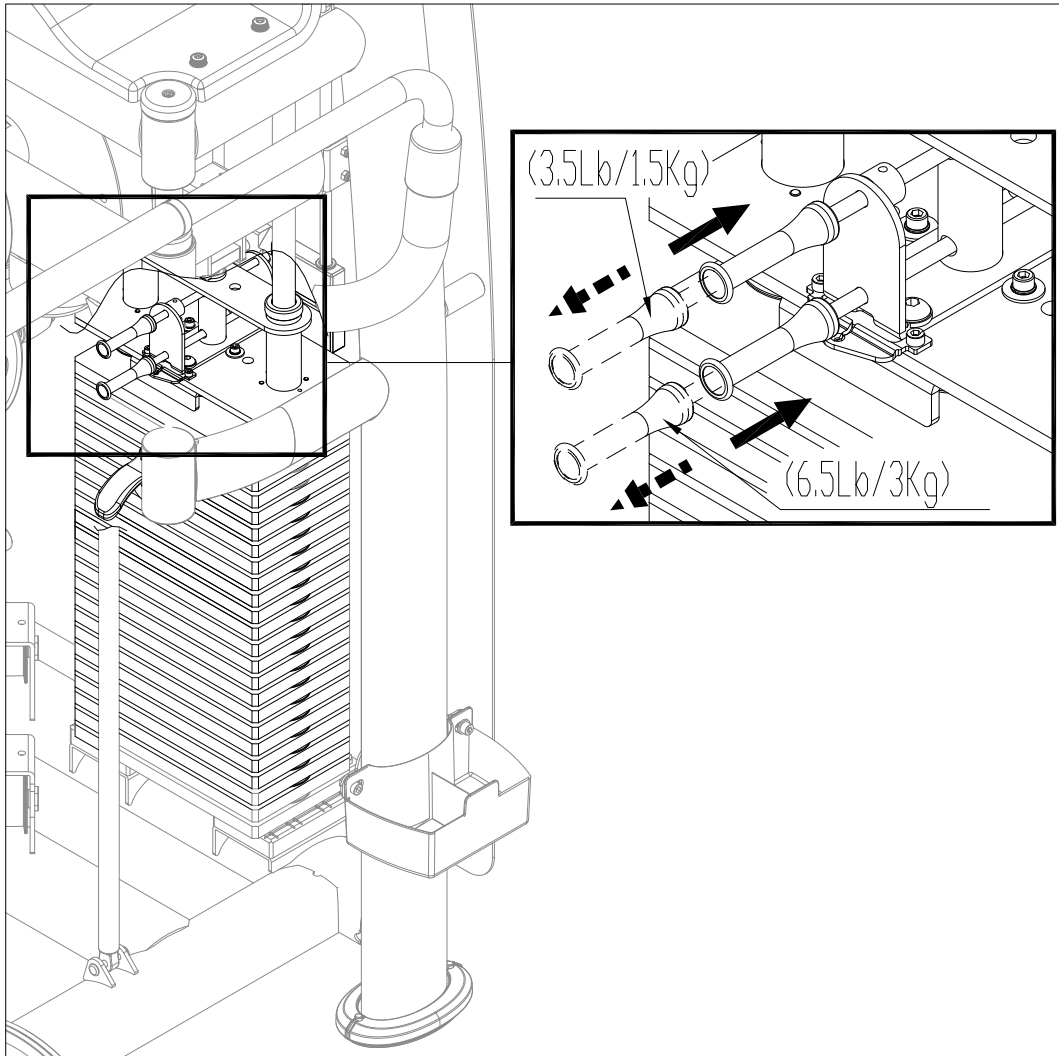

STEP 8 Belt Tension Adjustment Instructions

1. After the installation and the final positioning of the machine, make the appropriate adjustments to ensure that the machine is working.
2. If the belt is too tight or too loose, first loosen nut A as shown then adjust nut B. If the belt length is too long, adjust downward; if the belt length is too short, adjust upward. Adjust the belt to the proper position, then tighten nut A to secure the belt length.
Note: After adjusting the belt, the gap between nut A and B must be within 35mm (1.4").
3. After the adjustment, then the machine should be tested to determine the functionality of the machine.

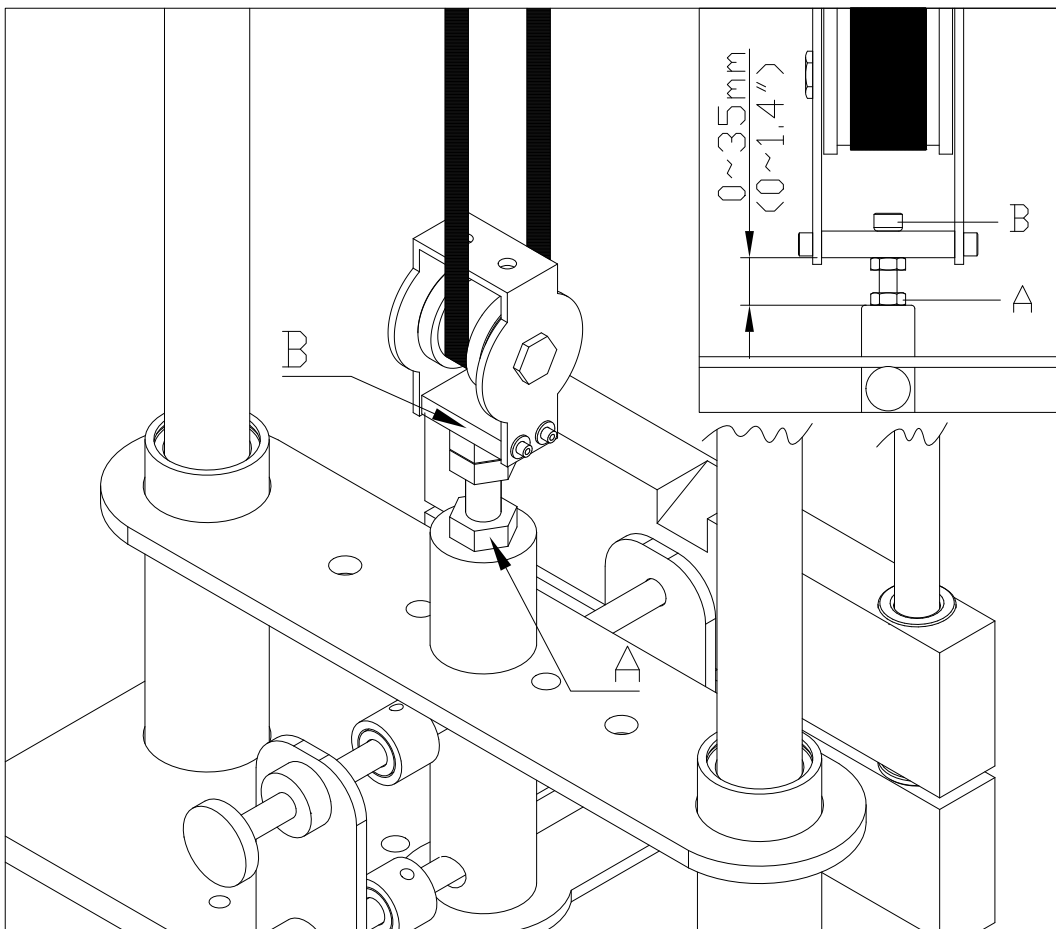

5. OPERATE THE PRODUCT

OPERATION Operate the Product

- (a). The rotator adjusting pin is used for adjusting the rotator to the proper initial position for the user. Shown in area (A).
- (b). The rotator adjusting pin is used for user to adjust the plate to the proper position. Shown in area (B). Make sure the leg cushion is secure in position before exercising.

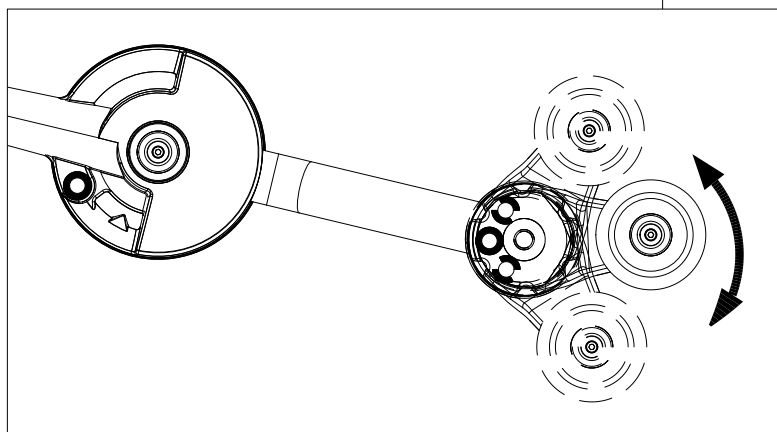
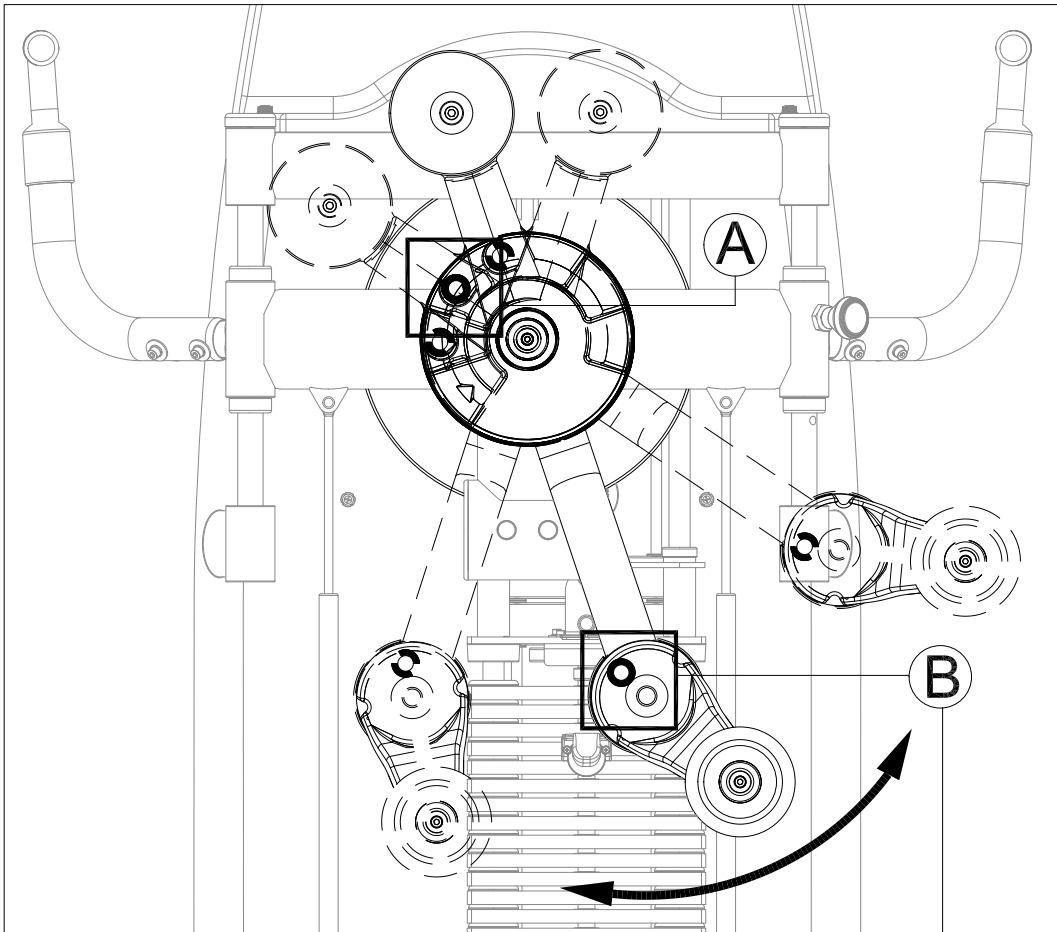

6. MAINTENANCE

This section covers maintenance topics and includes a maintenance schedule, task list, and log.

MAINTENANCE Machine Maintenance

1. Please clean and lubricate the guide rod once a week.
 - (a). Use a clean, lint-free towel to apply the lubricant onto the guide rods.
 - (b). Test the weight stack on the guide rod and make sure the operation is smooth.
 - (c). Repeat operations (a) and (b) 2 to 3 times.
2. Check the tightness of the cable or belt and follow the steps to make adjustments.

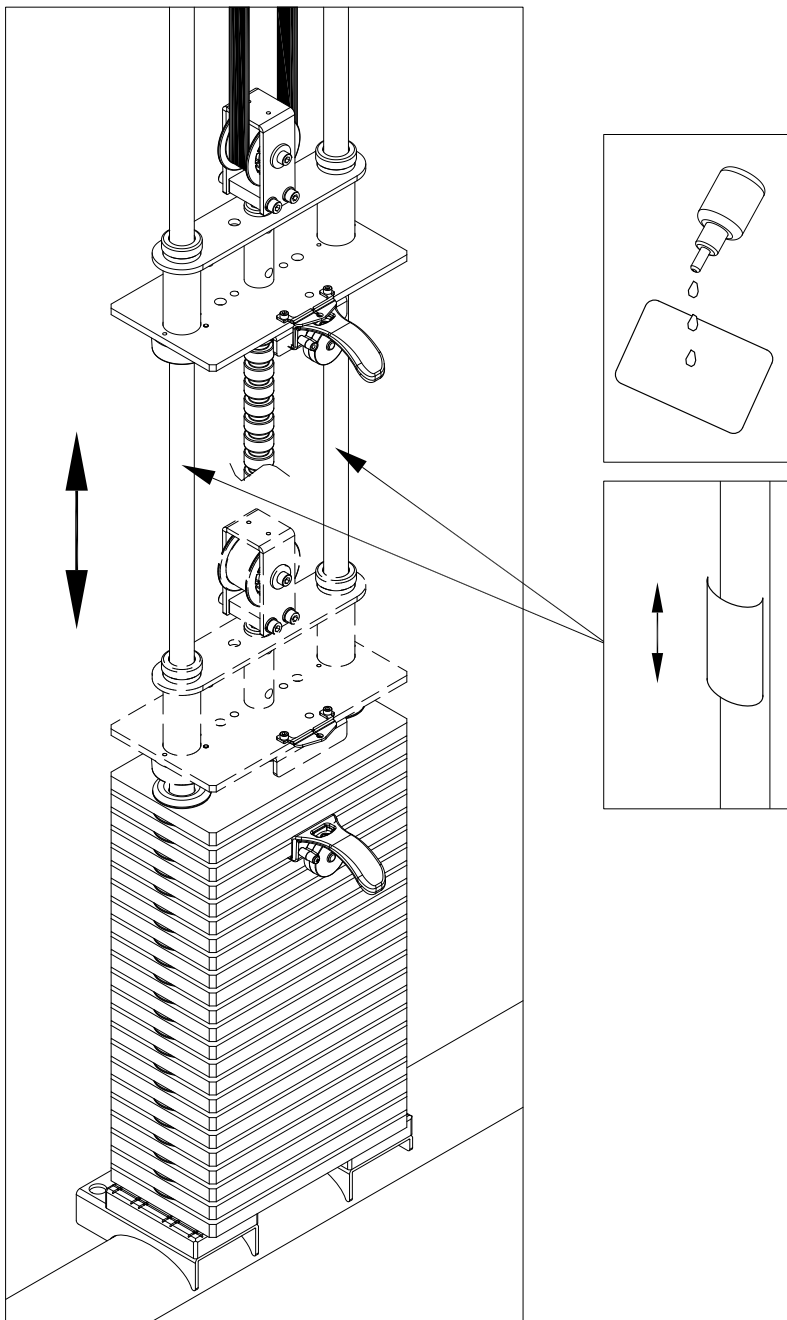

MAINTENANCE Machine Maintenance

IMPORTANT NOTE

1. Once the machine belt reaches the warranty period, it is recommended to replace the belt.
2. Belt safety check, after a year in use, check belt weekly. Depend on the use conditions, increase the frequency of inspections.

(As shown: (A) a belt, (B) the belt extension)

During inspection, if found cracks in the belt or the belt is exposed to other unusual circumstances, please immediately stop using the machine and replace the belt.

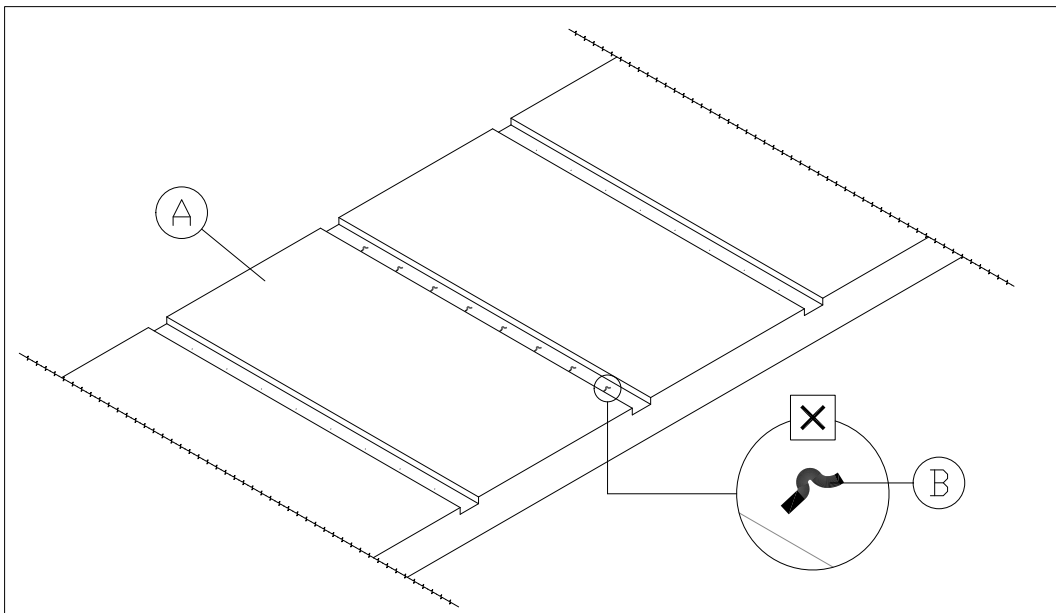

MAINTENANCE Schedule

	Area	Day	Week	Month	Quarter	Year	Notes
1	Exterior	■					Clean.
2	Screws	■					Inspect for looseness and secure if necessary.
3	Testing	■					To confirm that the machine is working properly
4	Glide Rail	■					Wipe dirt off with a cloth.
5	Belt		■				Check for damage or wear. If so, need for replacement.
6	Guide Rod		■				Clean and lubricate.

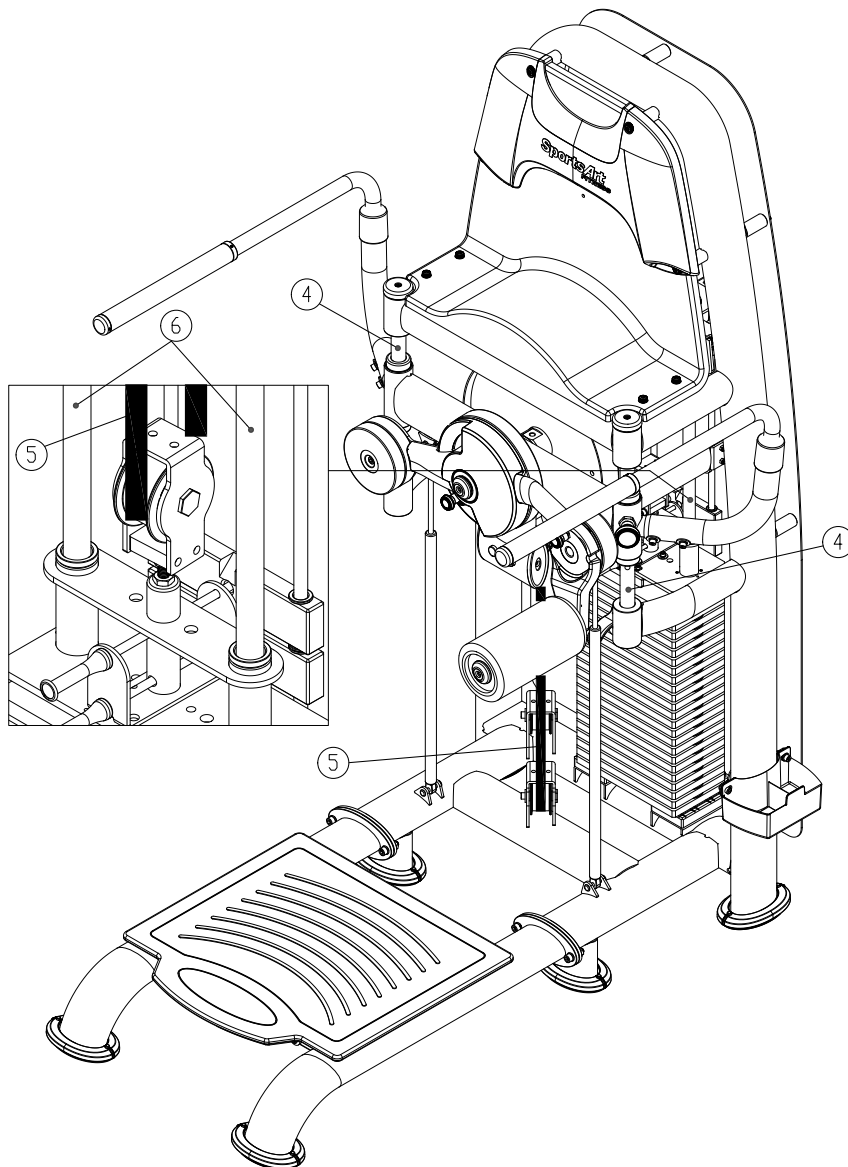

MAINTENANCE Task List

Like cars, fitness products require maintenance. Regular maintenance extends product life, and failure to maintain products can void the manufacturer's warranty. Copy the maintenance log sheet, and record maintenance work for each fitness product.

Daily tasks

1. Use a clean, lint-free towel to wipe down the product exterior.
2. Inspect all screws. Secure if necessary.
3. Make sure the machine is working properly.
4. Wipe glide rail clean with a cloth.

Weekly tasks

1. Check the belt for damage or tear.
2. Clean and lubricate guide rods.

Caution

- Please follow standard safety precautions when working on this product.
- Do NOT use cleaners with alcohol, ammonia, or other damaging chemicals. The use of such chemicals can damage the product and void the warranty. Never spray or pour any liquid directly onto the product. Doing so can damage components and void the warranty.

MAINTENANCE One-Year Maintenance Log

Facility: _____ Supervisor: _____

Product model number: _____ Serial number: _____

Start date: _____ End date: _____

Daily Tasks	Weeks 1-7	Weeks 8-14	Weeks 15-21	Week 22-28
Completed	<input type="checkbox"/>	<input type="checkbox"/>	<input type="checkbox"/>	<input type="checkbox"/>

Daily Tasks	Week 29-35	Week 36-42	Week 43-49	Week 50-52
Completed	<input type="checkbox"/>	<input type="checkbox"/>	<input type="checkbox"/>	<input type="checkbox"/>

Weekly Tasks	Weeks 1-7	Weeks 8-14	Weeks 15-21	Weeks 22-28
Completed	<input type="checkbox"/>	<input type="checkbox"/>	<input type="checkbox"/>	<input type="checkbox"/>

Weekly Tasks	Weeks 29-35	Weeks 35-42	Weeks 43-49	Weeks 50-52
Completed	<input type="checkbox"/>	<input type="checkbox"/>	<input type="checkbox"/>	<input type="checkbox"/>

Monthly tasks	1	2	3	4	5	6	7	8	9	10	11	12
Completed	<input type="checkbox"/>	<input type="checkbox"/>	<input type="checkbox"/>	<input type="checkbox"/>	<input type="checkbox"/>	<input type="checkbox"/>	<input type="checkbox"/>	<input type="checkbox"/>	<input type="checkbox"/>	<input type="checkbox"/>	<input type="checkbox"/>	<input type="checkbox"/>

Quarterly Tasks	Quarter 1	Quarter 2	Quarter 3	Quarter 4
Completed	<input type="checkbox"/>	<input type="checkbox"/>	<input type="checkbox"/>	<input type="checkbox"/>

Yearly Tasks	Year 1
Completed	<input type="checkbox"/>

Notes: _____

7. CONSIGNES DE SÉCURITÉ IMPORTANTES

Le produit SportsArt a été conçu et fabriqué afin d'assurer une sécurité optimale. Cependant certaines précautions s'appliquent chaque fois que vous utilisez votre produit.

- Lisez entièrement le manuel avant l'assemblage et l'utilisation. Veuillez aussi noter les consignes de sécurité suivantes:
- Veuillez lire attentivement les instructions et installer le produit selon les instructions.
- Assemblez et faites fonctionner le produit sur une surface solide et plane; NE PAS l'utiliser à l'extérieur ou près de l'eau.
- En aucun cas, ne laissez des enfants à proximité ou sur le produit.
- Vérifiez le tapis de course avant chaque utilisation. Assurez-vous que toutes les pièces sont assemblées et que tous les éléments de fixation sont serrés. NE PAS utiliser le produit si l'appareil est démonté de quelque façon.
- Gardez vos mains loin des pièces mobiles.
- Portez des vêtements d'entraînement appropriés; NE PORTEZ PAS de vêtements amples. NE PORTEZ PAS de chaussures à semelles en cuir ou à talons hauts. Attachez les cheveux longs.
- Soyez prudent lors du montage et démontage de l'appareil.
- NE PAS utiliser d'accessoire non spécifiquement recommandé par le fabricant. Car cela pourraient provoquer des blessures ou entraîner une panne de l'appareil.
- Débranchez l'appareil de la prise avant l'entretien ou la suppression de toute pièce.
- Une surveillance étroite est nécessaire quand de produit est utilisé par ou à proximité d'enfants, de malades ou de personnes handicapées.
- Utilisez ce produit uniquement pour l'usage prévu dans ce manuel.
- La limite de poids de l'utilisateur pour le produit est de 227 kg, 500 lb.
- Ce produit n'est pas destiné à être utilisé par des personnes (y compris des enfants) dont les capacités physiques, sensorielles ou mentales sont réduites ou qui ne disposent pas de l'expérience ou du savoir nécessaires, sauf si celles-ci ont au préalable été formées eu égard à l'utilisation de produit par une personne responsable de leur sécurité.
- Les enfants doivent être encadrés afin d'empêcher qu'ils ne jouent avec le produit.
- Ce produit n'est pas destiné à être utilisé par des personnes (y compris des enfants) dont les capacités physiques, sensorielles ou mentales sont réduites ou qui ne disposent pas de l'expérience ou du savoir nécessaires, sauf si celles-ci ont au préalable été formées eu égard à l'utilisation de ce produit par une personne responsable de leur sécurité.
- Les enfants doivent être encadrés afin d'empêcher qu'ils ne jouent avec le produit.

ATTENTION

Si vous ressentez une douleur ou si vous avez une sensation anormale, **ARRÊTEZ VOTRE ENTRAÎNEMENT** et consultez immédiatement votre médecin. Entraînez-vous à votre niveau d'exercice recommandé. NE PAS s'entraîner jusqu'à l'épuisement. Avant de commencer un programme d'exercice, vous devriez consulter votre médecin. Il est recommandé de faire un examen physique complet. Dans ce manuel, les mots "gauche" et "droit" sont utilisés en référence aux pièces et au produit. Comme tels, les mots "gauche" et "droit" font respectivement référence aux côtés gauche et droit de l'exerciseur. De même pour plus de concision, le mot «vis» est utilisé dans certains cas où des rondelles, des vis et autres matériels sont associés.

S961 Total Hip

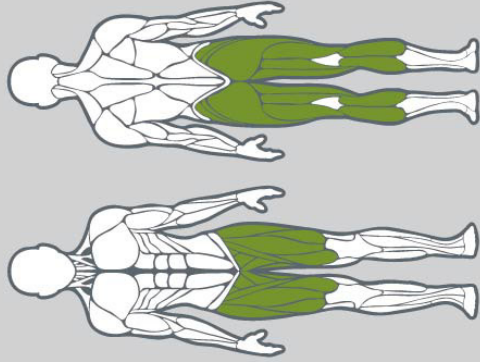

www.sportsartfitness.com

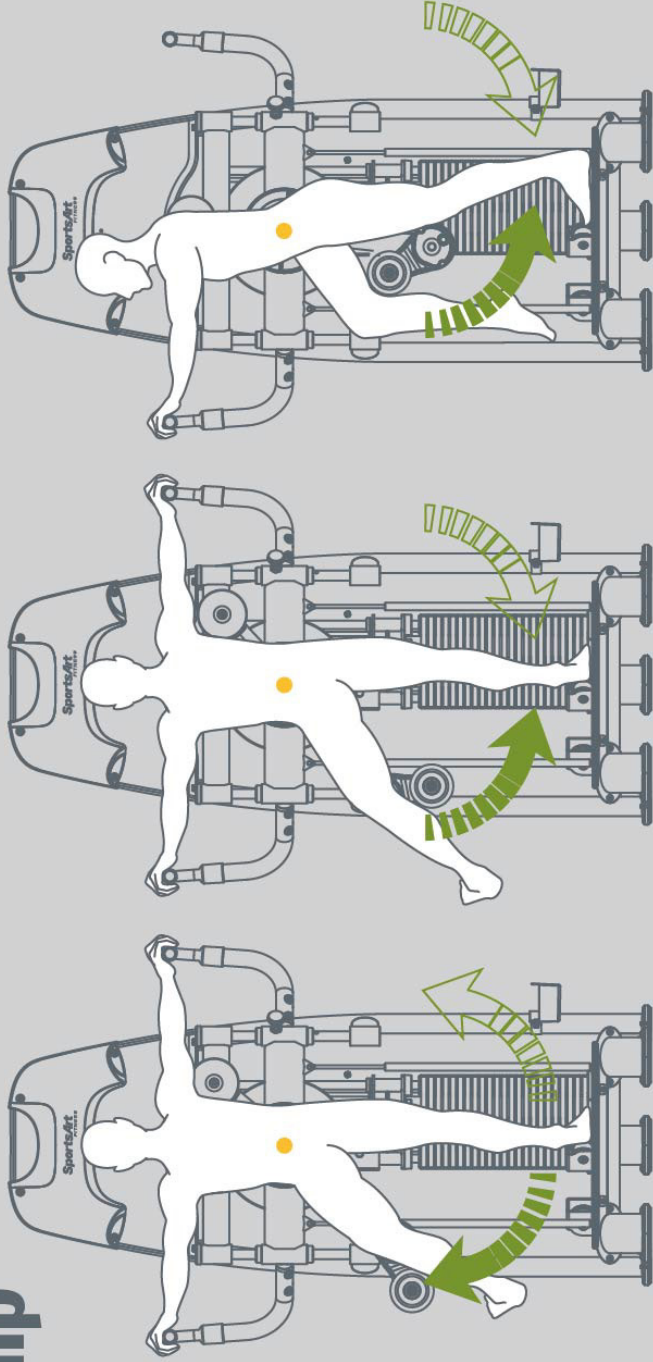

CAUTION

Do not use this machine if you are unfamiliar or do not know how to operate it. Do not allow people near this machine when in use. Keep clear of parts not intended for contact during exercise. For your safety, exhale while you exert force.

- 1 Adjust cushion to the appropriate position for the desired exercise.
- 2 Select a weight level that enables you to perform movements correctly and comfortably.
- 3 Grasp handles for stability and balance.
- 4 Perform exercises in a controlled manner.
- 5 Exhale when pushing against resistance.