



Protekt Akra™ Home Care Beds

User Manual & Entrapment Guide



For Use with Model's:

Protekt Akra-SE™ Semi-Electric Bed, Spring Deck, Half Rails	PMSEBHR
Protekt Akra-SE™ Semi-Electric Bed, Spring Deck, Full Rails	PMSEBFR
Protekt Akra-FE™ Full-Electric Bed, Spring Deck, Half Rails	PMFEBHR
Protekt Akra-FE™ Full-Electric Bed, Spring Deck, Full Rails	PMFEBFR

Table Of Contents

Special Notes	4
Warnings	4
Bed Assembly	5-10
Unpacking the Bed	5
Connecting the Two Frames	6-7
Connecting the Spring “Lattice”	8
Installing the Casters	9
Installing the Headboard and Footboard	10
Bed Operation	11
Hand Control Pendant.....	11
Installing the Electric Motor Unit	12-13
Head/Foot Electric Motor Units	12
Installing Drive Shaft - Semi Electric Bed	14
Installing Drive Shaft - Full Electric Bed	15
Height Adjustment-Pin Installation (Full & Semi Electric Beds) ...	15
Hand Crank for the Semi-Electric Bed	16
Bed Rail Installation	17
Maintenance and Safety Checks	18
Electronics	18
Bed Frame and Sleeping Surface	18
Cleaning	18
Lubrication and Mechanical	18
Warranty	18
Entrapment Guide	19-26
Key Body Parts at Risk	19
Head	19
Neck	19
Chest	19
Potential Zones of Entrapment	20
Dimensional Limits for Identified Entrapment Zones	20
A Guide to Bed Safety	24
Protekt® Home Care Beds Part List	25
Meeting Patients’ Needs for Safety	26
Patient or Family Concerns about Bedrail Use	26

SPECIAL NOTES

NOTICE:

- The information contained in this document is subject to change without notice.
- WARNINGS/CAUTION notices used in this manual apply to hazards or unsafe practices which could result in personal injury and/or property damage.
- Check all parts for shipping damage and test before using. In case of a damage, do NOT use.
- Contact the dealer for further instruction.

WARNING

PLEASE READ ALL WARNINGS/CAUTIONS BEFORE USE:

- Your Manual/Electric bed has been totally engineered to provide you with reliable operation and the strength you deserve.
- The bed has been thoroughly tested and inspected prior to shipment.
- The utmost in comfort and safety has been provided for you. The bed is for your HOME use only.
- It is NOT for hospital use and was not designed to meet hospital standards.
- DO NOT use near explosive gases.
- Possible fire hazard when used with oxygen administering equipment other than nasal or masked type.
- When using nasal or masked type administering equipment, oxygen or air tubing MUST be routed and secured properly to ensure that tubing does NOT become entangled and eventually severed during normal operation of Manual/Electric bed.

WARNING

- When using liquids in or around the bed, caution should be taken to ensure that liquids of any kind are not spilled in or around the bed.
- If a spill occurs, UNPLUG the bed immediately.
- Clean up spill and allow bed or area to dry thoroughly before using the electric controls again.
- Close supervision is necessary when this product is used by or near CHILDREN OR PHYSICALLY CHALLENGED INDIVIDUALS.
- This product should never be left unattended when plugged in.
- NEVER PERMIT ANY ONE UNDER THE BED AT ANYTIME.
- When operating or moving the bed, ALWAYS ensure that the individual utilizing the bed is positioned properly within the confines of the bed.
- DO NOT let any extremities protrude over the side or between the bed rails when performing these functions.

Bed Assembly

Unpacking the Bed

The Home Care Bed will arrive in two (2) boxes with the following contents:

Box 1 of 2 includes:

- 1 Headboard
- 1 Footboard
- 1 Hand Crank (included with Semi-Electric model only)
- 4 Casters (2 locking, 2 non-locking)
- 4 Pins
- 1 Manual

Box 2 of 2 includes:

- 1 Head Spring Section
- 1 Foot Spring Section
- 1 Drive Shaft (Semi-Electric bed: length adjustable, Full-Electric bed: 2 pieces)
- 1 Dual Motor
- 1 Hand Pendant
- 1 Side Rails (Full or Half Length)

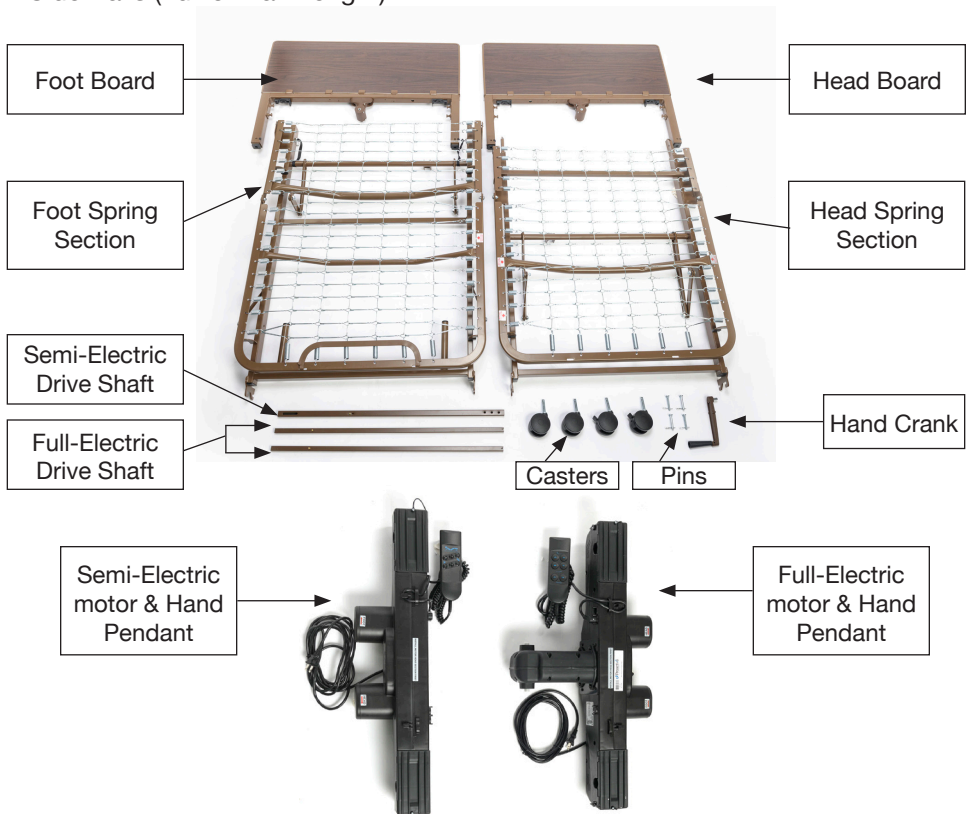

* For shipping purposes, the motor is attached to the frame, but is NOT installed for operation. The motor needs to be removed & installed per the following instructions.

Connecting the Two Frames

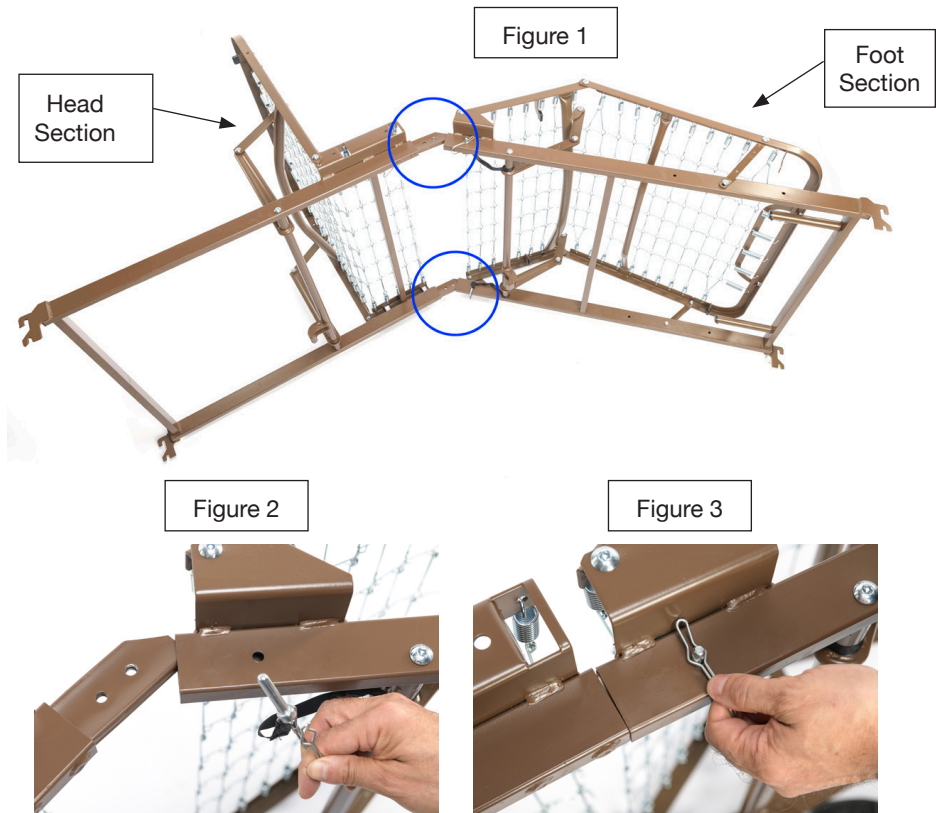

Connecting the Two Frames:

1. Place the Head Spring Section on its side to your left with the center mounting shaft to the right. (See figure 1)
2. Place the Foot Spring Section on its side to your right with the head frame pull tube at the top of the assembly and the center mounting input shaft facing to the left and remove locking pin from both sides. (See figure 2)
3. The crank handles and/or motors should be at your right.
4. The head and foot springs should now be on their sides at approximately a 90° angle to one another.
5. Place the head spring center mounting shaft to the foot spring center mounting input. (See figures 2 and 3)

6. After head and foot spring shafts are connected, insert locking pins and slowly open the frame sections into a horizontal (straight) position while still on their sides. Make sure the frame mounting shafts are locked in place with locking pins at all times.



7. Lay the bed flat with the springs facing up.

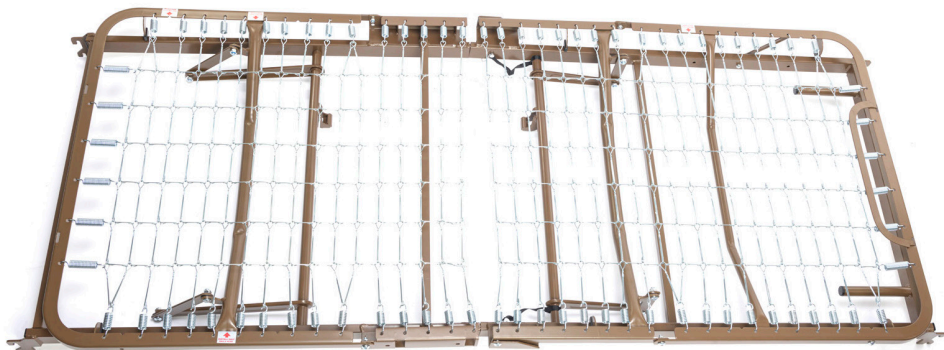

Connecting the Spring “Lattice”

Connecting the Spring “Lattice”:

1. With the bed flat and the springs facing up, lift the head spring section upward to give slack to the spring “lattice.”



2. Connect the spring “lattice” together with the links provided.
3. Hook together all the links to the spring “lattice.”



Installing the Casters

To Install Casters:

Ensure that the locking casters are installed diagonally from each other and are locked. This will provide maximum locking security.



1. Position the two locking casters so they will be diagonally opposite from one another when the bed is assembled.
2. Insert the shaft of the caster into the caster socket of each bed leg. Ensure the stem is fully inserted into the socket.



3. To prevent excess movement of the bed during assembly, lock each of the two locking casters by pushing **down** on the caster lock.
Note: Locking the casters may not prevent the bed from moving on slick or slippery surfaces.
4. To unlock the two locking casters, pull up on the caster lock.

Installing the Headboard and Footboard

CAUTION: Do not place your hand between the spring section and the bed ends while attaching the bed boards as injury may occur.

To Attach the Head and Foot Boards:

1. Stand the headboard section as close to the head frame as possible.



2. Raise the head frame until the rivets on the corner plates of the head frame fit into the corner locks on the headboard. The headboard may need to be tilted backward slightly for the rivets to slide into the locks.
3. Return the headboard to its full upright position to lock it into place.
4. Repeat steps 1-3 for the “Foot Board” section.

Bed Operation

Hand Control Pendant: Semi-Electric & Full-Electric Beds



Semi-Electric Hand Pendant



Full-Electric Hand Pendant



BATTERY BACKUP

In the event of the power failure, the standard 9 volt battery in the motor:

- ✓ Will allow the user to lower the head and foot sections of the bed.
- ⚠ Will NOT allow the bed's motor to lift the head or foot sections.
NOTE: Periodically replace the battery

Installing the Electric Motor Unit

Head/Foot Electric Motor Units

1. Before installing: Make sure that the hand pendant cable is plugged into the motor.



2. Connect the 9V battery (sold separately) to the battery clip on the motor. It is stored in the recess on the side of the motor. With this battery installed, the motor can be operated to return the sleep surface to the horizontal position in the event of a power failure.



3. Locate the slide caps. Remove the slide caps from both ends of the motor.



4. Prior to installation, make sure that the 2 motor blocks are in the retracted position.

Motor Blocks



5. Full-Electric Bed Only - Insert the adapter into the clip.

Aligning and Mounting the Motor

1. With the motor oriented properly underneath the bed (head to head, foot to foot), align the motor with actuator bar and lift the head spring to the highest position. The motor will automatically be pulled towards the bed and lock onto the actuator.

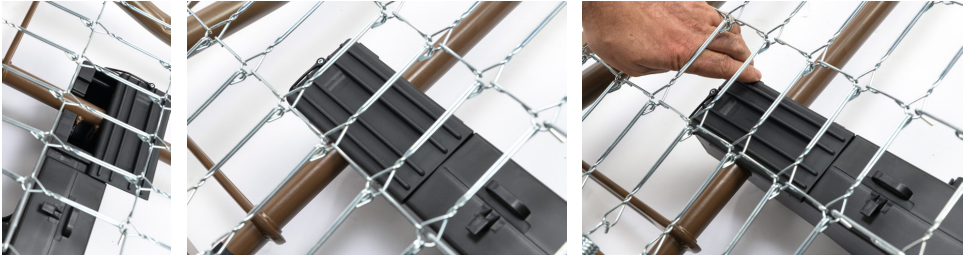

2. Once the head side of the motor is attached to the head section of the bed, return the head section of the bed, return the head section to the flat position.

3. Once flat, attach slide caps to the head section of the motor and slide it into place. Repeat for foot section.

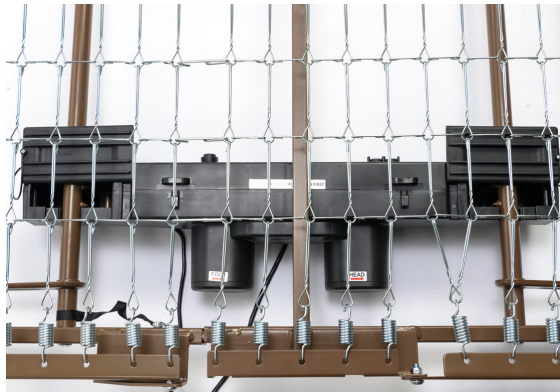

4. Completed Assembly.



Installing Drive Shaft Semi-Electric Bed

1. Assemble the drive shaft as pictured in figures 1, 2, and 3.

Figure 1



Figure 2



Figure 3



2. Attach 1 side of the drive shaft to the headboard gear box and the other end to the footboard gear box as pictured in figure 4.

Figure 4



3. Attach the hand crank to the outside of the footboard gear box as shown in figure 5.

Figure 5



Installing Drive Shaft Full-Electric Bed

1. Take 1 drive shaft and connect 1 end to the headboard gear box as pictured in figures 1, 2, and 3.

Figure 1



Figure 2

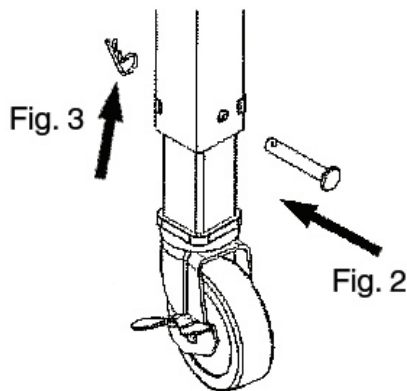

Figure 3



2. Take 1 drive shaft and connect 1 end to the footboard gear box as pictured in above figures 1, 2, and 3.

Optional Height Adjustment Pin Installation (Full & Semi Electric Beds)



- Insert lock pin through adjustment hole. (1" increments)
NOTE: If lock pin cannot insert through the holes easily, rotate the crank handle (clockwise or counter-clockwise) until the lock pin goes through. (Fig. 2)
- Secure lock pin with safety pin provided. (Fig. 3)
- Repeat on each remaining leg.

Hand Crank for the Semi-Electric Bed

The manual bed crank is located at the foot of the bed.



1. Before attempting to manually adjust the bed height, it is necessary to remove the optional height adjustment lock pins from each leg.
2. To raise the bed – Turn the crank handle clockwise.
3. To lower the bed – Turn the crank handle counter-clockwise.



- ⚠** If using the semi-electric bed footboard with a full-electric bed/motor, first remove the crank handle from the footboard. If left in place, the crank will turn when the motor is on and could cause personal injury or damage to the bed.

The Trendelenberg Position

A position in which the head is low and the body and legs are on an inclined plane.

Trendelenberg

1. Lower the bed to its lowest height. Disengage the drive shaft by compressing the spring fitting and removing the drive shaft from the Hi/Low Motor to the headboard gearbox.
2. Raise the foot end of the bed using the hand pendant or crank. The head end of the bed will remain in the low position.

Reverse Trendelenberg

1. Raise the bed to its highest height. Disengage the Hi/Lo drive shaft by compressing the spring fitting and removing the drive shaft from the motor to the foot end of the bed.
2. Lower the end of the bed using the hand pendant or crank. The head end of the bed will remain in the high position.

BED RAIL INSTALLATION

Full Bed Rails: To install Full Bed Rails, lift the head section and find the rail receptacle located on the frame of the bed as shown (Fig A). Pull receptacle outward and return head section to the flat position. Turn receptacle in a vertical position to receive the rail (Fig B). Repeat for all four rail receptacles.



A



B



Full Bed Rail Operation: Pull out Pull Pin on each bracket one at a time to raise or lower rail. Ensure Pull Pins are properly engaged to lock rails in position.

Half Bed Rails:

To install half rails, locate the label located on the head section of the frame (Fig D). The half rail clamp should be installed over this label. Align fixed clamp jaw (Fig E) in front of bed frame rail as shown below. Align movable clamp jaw on top of bed frame rail, and turn knob clockwise until clamp is tight, securing safety rail to bed frame rail (Fig F).



D



E



F



Half Bed Rail Operation: Pull out Pull Pin on each bracket to raise or lower rail. Ensure Pull Pin is properly engaged to lock rail in position.

NOTE: Bed rails should be removed when bed is disassembled to help prevent damage.

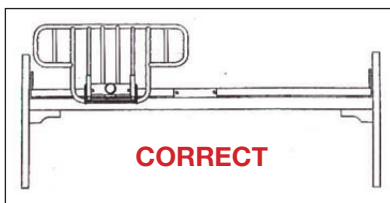

When installing bed rail, only place one (1) rail on bed per side.

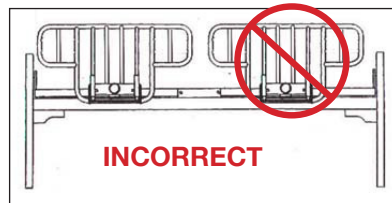

DO NOT place 2 bed rails on the same side of the bed as shown above.

WARNING - INCORRECT MOUNTING MAY CAUSE INJURY OR DEATH

MAINTENANCE AND SAFETY CHECKS

To be performed once per year or between patient placements.

Electronics

Check all controls to make sure all functions work properly.

- Power cord
- Pendant cord
- Check to make sure all wires are routed and attached properly so they do not interfere with any moving parts
- Check to make sure all plugs are fully inserted or attached

Bed Frame and Sleeping Surface

Visually check all welds

- Head section
- Knee section
- Main Frame
- Check joints between sleeping surface sections for loose fasteners

Cleaning

The metal parts of the bed are covered with a baked epoxy coating. Clean all coated parts with mild detergent and warm water. Periodically raise head and feet sections of the bed and remove dust from frame. Also, periodically remove the mattress and clean mattress deck.

Lubrication and Mechanical

- Lightly grease all actuator screw threads with white lithium grease
- Lubricate all caster roller and swivel bearings with light machine oil
- Check all bolts and tighten as needed

WARRANTY

- Limited lifetime on frame
- 2 Years on Motor

ENTRAPMENT GUIDE

Bed Rails in Nursing Homes and the Home Health Care Environment

KEY BODY PARTS AT RISK

Three key body parts at risk for life-threatening entrapment in the seven zones of a hospital bed system discussed in this guidance are the head, neck, and chest.

The body part dimensions used to develop FDA's dimensional limit recommendations are summarized as follows:

Key Body Part	Dimension
Head	120 mm (4-3/4 inches)
Neck	60 mm (2-3/8 inches and angle >60°)
Chest	318 mm (12-1/2 inches)

Head

To reduce the risk of head entrapment, openings in the bed system should not allow the widest part of a small head (head breadth measured across the face from ear to ear) to be trapped.

FDA is therefore using a head breadth dimension of 120 mm (4-3/4 inches) as the basis for its dimensional limit recommendations. This dimension is consistent with the dimensions recommended by the HBSW and the IEC.

Neck

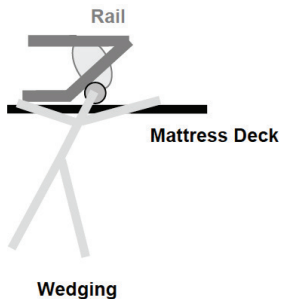

To reduce the risk of neck entrapment, openings in the bed system should not allow a small neck to become trapped.

Given the adult population at risk for wedging entrapments in hospital beds, FDA recommends a dimension of 60 mm (2-3/8 inches) to represent neck diameter.

Additionally, to prevent wedging, a limit of greater than 60° is recommended for V-shaped openings that a neck could enter. These dimensions are

consistent with the dimensions recommended by the HBSW and the IEC (see IEC 60601-2-38-1).

Chest

The openings in a bed system should be wide enough not to trap a large chest through the opening between split rails.

FDA concurs with the IEC recommended dimension of 318 mm (12-1/2 inches) to represent chest depth for the population vulnerable to entrapment, and has used this dimension as the basis for its recommended dimensional limits.

POTENTIAL ZONES OF ENTRAPMENT

This guidance describes seven zones in the hospital bed system where there is a potential for patient entrapment. Entrapment may occur in flat or articulated bed positions, with the rails fully raised or in intermediate positions.

The seven areas in the bed system where there is a potential for entrapment are identified in the drawing below.

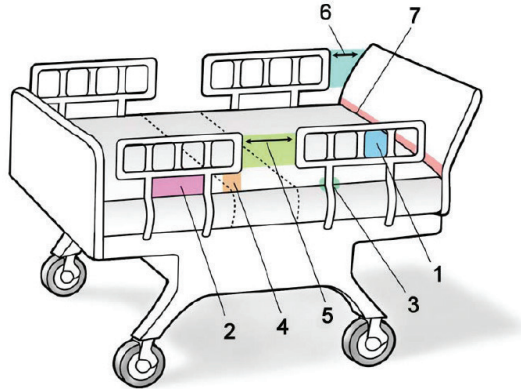

Zone 1	Within the rail
Zone 2	Under the rail, between the rail supports or next to a single rail support
Zone 3	Between the rail and the mattress
Zone 4	Under the rail, at the ends of the rail
Zone 5	Between split bed ends
Zone 6	Between the end of the rail and the side edge of the head or foot board
Zone 7	Between the head or foot board and the mattress end

DIMENSIONAL LIMITS FOR IDENTIFIED ENTRAPMENT ZONES

Summary of FDA Hospital Bed Dimensions Limit Recommendations

Zone	Dimensional Limit Recommendations
1 Within the rail	< 120 mm (< 4-¾ inches)
2 Under the rail, between rail supports or next to a single rail support	< 120 mm (< 4-¾ inches)
3 Between the rail and mattress	< 120 mm (< 4-¾ inches)
4 Under the rail, at the ends of the rails	(< 2-3/8") AND > 60° angle

Zone 1 – Within the Rails



This is any open space within the perimeter of the rail. Openings in the rail should be small enough to prevent the head from entering. A loosened bar or rail can change the size of the space. The HBSW and IEC recommend that the space be less than 120 mm (4-¾ inches), representing head breadth.

Zone 2 – Under the Rail, Between the Rail Supports or Next to a Single Rail Support

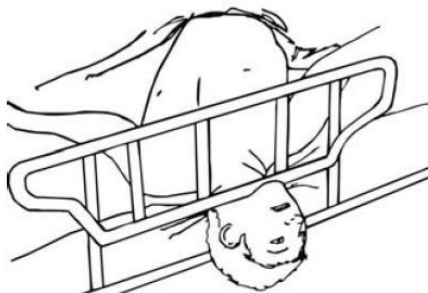

This space is the gap under the rail between a mattress compressed by the weight of a patient's head and the bottom edge of the rail at a location between the rail supports, or next to a single rail support. If there is a single rail support, entrapment in Zone 2 can occur anywhere along the bottom length of the rail beyond the support, up to the end of the rail. (Entrapment at the end of the rail is explained in Zone 4.) Factors to consider are the mattress compressibility 17 which may change over time due to wear, the lateral shift of the mattress or rail, and any degree of play from loosened rails or rail supports. A restless patient may enlarge the space by compressing the mattress beyond the specified dimensional limit. This space may also change with different rail height positions and as the head or foot sections of the bed are raised and lowered. The space may increase, decrease, become less accessible, or disappear entirely. In some positions, the potential for entrapment in this zone may still exist when the deck is articulated. Preventing the head from entering under the rail would most likely prevent neck entrapment in this space. FDA recommends that this space be small enough to prevent head entrapment, less than 120 mm (4 ¾ inches). IEC recommends the same dimensions but measures the space without the mattress in place.

Zone 3 — Between the Rail and the Mattress



This area is the space between the inside surface of the rail and the mattress compressed by the weight of a patient's head. The space should be small enough to prevent head entrapment when taking into account the mattress compressibility, any lateral shift of the mattress or rail, and degree of play from loosened rails. HBSW and IEC recommend a dimension of less than 120 mm (4 ¾ inches) because the head is presumed to enter the space before the neck. FDA is recommending a dimensional limit of less than 120 mm (4 ¾ inches) for the area between the inside surface of the rail and the compressed mattress.

Zone 4 — Under the Rail at the Ends of the Rail



This space is the gap that forms between the mattress compressed by the patient, and the lowermost portion of the rail, at the end of the rail. Factors that may increase the gap size are: mattress compressibility, lateral shift of the mattress or rail, and degree of play from loosened rails. The space poses a risk for entrapment of a patient's neck. It may change with different rail height positions and as the head or foot sections of the bed are raised and lowered. The space may increase, decrease, become less accessible, or disappear entirely. Thus, in some positions, the potential for entrapment in this zone may still exist when the deck is articulated. At the time of this publication, the IEC international standard recommends a dimensional limit of less than 60 mm (2 3/8 inches) measured between the mattress support platform and the lowest portion of the rail at the rail end to prevent neck entrapment. Based on the neck diameter dimension described above, FDA recommends that the dimensional limit for this space also be less than 60 mm (2 3/8 inches). To reduce the risk of neck entrapment at Zone 4, FDA recommends consideration of the combination of the gap size and the angle size (created between the mattress and the rail). Thus, FDA recommends that the V-shaped opening under the rail at its end be of an angle wide enough, i.e. greater than 60 degrees, to prevent wedging entrapment.

Zone 5, 6 and 7

Although seven potential zones of entrapment have been identified by HBSW, FDA is recommending dimensional limits for zones 1-4 because these zones were most frequently reported as having entrapments.

FDA continues to receive entrapment reports for Zones 5 and 6, and Zone 7 remains a potential for entrapment. FDA will monitor entrapments in these zones and consider harmonization with the IEC standard once it is available.

Zone 5 – Between Split Bed Rails



This zone occurs when partial length head and foot side rails (split rails) are used on the same side of the bed. The space between the split rails may present a risk of either neck entrapment or chest entrapment between the rails if a patient attempts to, or accidentally, exits the bed at this location. In addition, any V-shaped opening between the rails may present a risk of entrapment due to wedging. FDA recognizes this area as a potential for entrapment and encourages facilities and manufacturers to report entrapment events at this zone.

Zone 6 – Between the End of the Rail and the Side Edge of the Head or Foot Board



This is the space between the end of the rail and the side edge of the headboard or footboard. This space may present a risk of either neck entrapment or chest entrapment. In addition, any V-shaped opening between the end of the rail and the head or footboard may present a risk of entrapment due to wedging. This space may change when raising or lowering the head or foot sections of the bed. This space may increase, decrease, become less accessible, or disappear entirely. Thus, in some positions, the potential for entrapment may exist when the deck is articulated. FDA recognizes this area as a potential for entrapment and encourages facilities and manufacturers to report entrapment events at this zone.

Zone 7 — Between the Head or Foot Board and the End of the Mattress

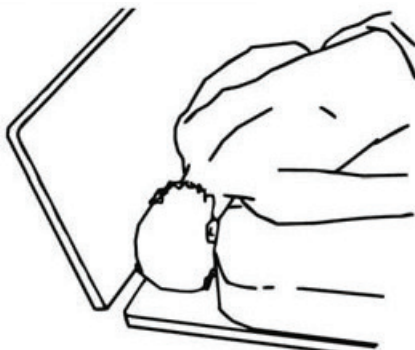

This is the space between the inside surface of the head board or foot board and the end of the mattress. This space may present a risk of head entrapment when taking into account the mattress compressibility, any shift of the mattress, and degree of play from loosened head or foot boards. FDA recognizes this area as a potential for entrapment and encourages facilities and manufacturers to report entrapment events at this zone.

Patient Safety

Patients who have problems with memory, sleeping, incontinence, pain, uncontrolled body movement, or who get out of bed and walk unsafely without assistance, must be carefully assessed for the best ways to keep them from harm, such as falling. Assessment by the patient's health care team will help to determine how best to keep the patient safe. Historically, physical restraints (such as vests, ankle or wrist restraints) were used to try to keep patients safe in health care facilities. In recent years, the health care community has recognized that physically restraining patients can be dangerous. Although not indicated for this use, bed rails are sometimes used as restraints. Regulatory agencies, health care organizations, product manufacturers and advocacy groups encourage hospitals, nursing homes and home care providers to assess patients' needs and to provide safe care without restraints.

Protekt® Home Care Beds Part List:

Item#	Description	Bed Style	UOM
BP-FR	Full Length Side Rails	Semi/Full	Pair
BP-HR	Half Side Rails	Semi/Full	Pair
BP-HB	HeadBoard Complete,1ea	Semi/Full	Each
BP-FB	FootBoard Complete,1ea	Semi/Full	Each
BP-HS	HeadSpring Complete,1ea	Semi/Full	Each
BP-FS	FootSpring Complete,,1ea	Semi/Full	Each
BP-C	Caster,w/o locking,1ea	Semi/Full	Each
BP-LC	Caster,w/locking,1ea	Semi/Full	Each
BP-HP	Plastic panel,Head,1ea	Semi/Full	Each
BP-FP	Plastic panel,Foot,1ea	Semi/Full	Each
BP-GBH	Gearbox,head,1ea	Semi/Full	Each
BP-GBF	Gearbox,foot,1ea	Semi/Full	Each
BP-SEHC	Handcrank,semi electric,1ea	Semi	Each
BP-SEM	Motor,Box,semi electric,1ea	Semi	Each
BP-SEPNDT	Hand controller,semi electric,1ea	Semi	Each
BP-SESH	Drive Shaft,Semi electric,1ea	Semi	Each
BP-FEKIT	Full Electric Conversion Kit (convert semi to full)	Full	Pack
BP-FEMB	Motor,Box,full electric,1ea	Full	Each
BP-FEPNDT	Hand controller,full electric,1ea	Full	Each
BP-FESH	Drive Shaft,full electric,1ea	Full	Each

The Benefits and Risks of Bed Rails

Potential benefits of bed rails include:

- Aiding in turning and repositioning within the bed.
- Providing a hand-hold for getting into or out of bed.
- Providing a feeling of comfort and security.
- Reducing the risk of patients falling out of bed when being transported.
- Providing easy access to bed controls and personal care items.

Potential risks of bed rails may include:

- Strangling, suffocating, bodily injury or death when patients or part of their body are caught between rails or between the bed rails and mattress.
- More serious injuries from falls when patients climb over rails. Skin bruising, cuts, and scrapes.
- Inducing agitated behavior when bed rails are used as a restraint.
- Feeling isolated or unnecessarily restricted.
- Preventing patients, who are able to get out of bed, from performing routine activities such as going to the bathroom or retrieving something from a closet.

Which Ways of Reducing Risks are Best?

A process that requires ongoing patient evaluation and monitoring will result in optimizing bed safety. Many patients go through a period of adjustment to become comfortable with new options. Patients and their families should talk to their health care planning team to find out which options are best for them.

MEETING PATIENTS' NEEDS FOR SAFETY

Most patients can be in bed safely without bed rails. Consider the following:

- Use beds that can be raised and lowered close to the floor to accommodate both patient and health care worker needs.
- Keep the bed in the lowest position with wheels locked.
- When the patient is at risk of falling out of bed, place mats next to the bed, as long as this does not create a greater risk of accident.
- Use transfer or mobility aids.
- Monitor patients frequently.
- Anticipate the reasons patients get out of bed such as hunger, thirst, going to the bathroom, restlessness and pain; meet these needs by offering food and fluids, scheduling ample toileting, and providing calming interventions and pain relief.

When bed rails are used, perform an on-going assessment of the patient's physical and mental status; closely monitor high-risk patients. Consider the following:

- Lower one or more sections of the bed rail, such as the foot rail.
- Use a proper size mattress or mattress with raised foam edges to prevent patients from being trapped between the mattress and rail.
- Reduce the gaps between the mattress and side rails.

PATIENT OR FAMILY CONCERNS ABOUT BED RAIL USE

If patients or family ask about using bed rails, health care providers should:

- Encourage patients or family to talk to their health care planning team to determine whether or not bed rails are indicated.
- Reassure patients and their families that in many cases the patient can sleep safely without bed rails.
- Reassess the need for using bed rails on a frequent, regular basis.

To report an adverse event or medical device problem,
please call FDA's MedWatch Reporting Program
at 1-800-FDA-1088.

For additional information, visit the FDA's website at:
<http://www.fda.gov/medicaldevices>



Proactive Medical Products