

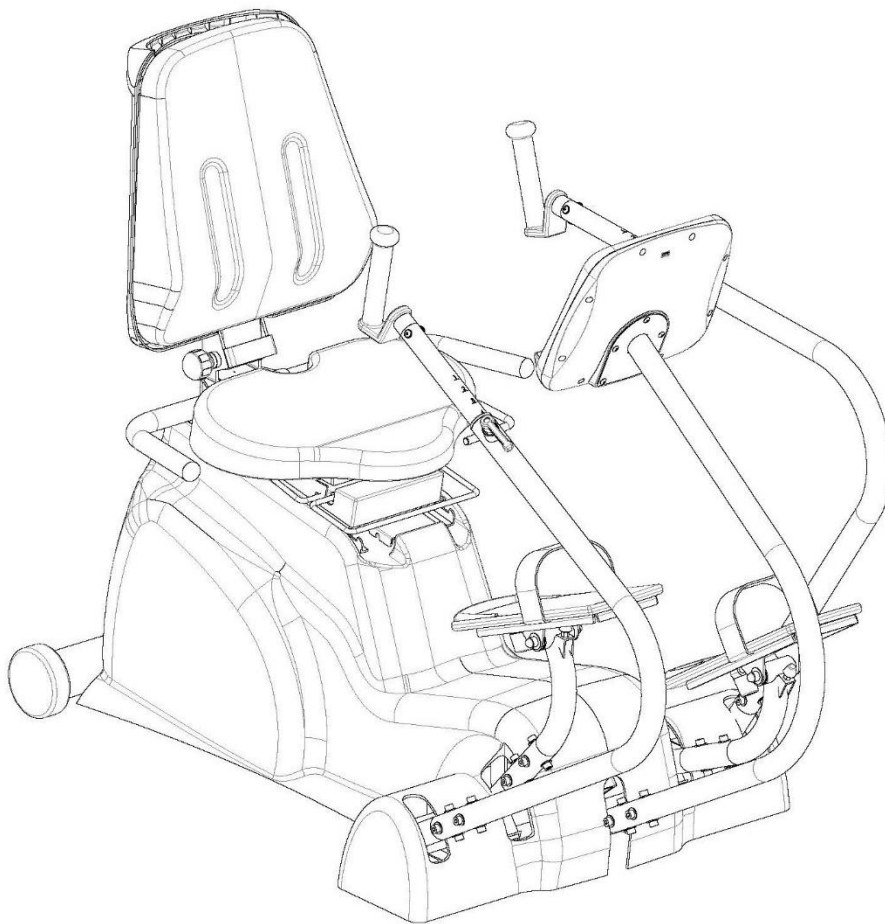

Owner's Manual V.2.2



HealthCare International, Inc.
PO Box 1509, Langley, WA 98260
www.HCIFitness.com – sales@hCIFitness.com
P: (360) 321-7090 or (800) 398-9121

Table of Contents

Quick Tips	8
AC Adaptor:	8
Levelers:	8
Seat Adjustments:.....	8
Quick Start:.....	8
Heart Rate:	8
USB Workout Summary Report:	8
PhysioStep LXT Display Console.....	9
Button Functions	10
Quick Start –Sit, Start, & Step!	11
Select a Workout Program	11
Setup your Workout Programs	12
User Setup:.....	12
1. Basic Programs.....	13
2. Heart Rate Programs (HR 65% / HR 85%)	14
3. Constant Programs (SPM / WATTS).....	15
4. Goal Set Programs (Calories / Distance)	16
Cool Down Mode.....	17
Workout Summary Mode.....	17
Export Workout Summary to USB.....	17
Sleep Mode	18
Recovery Mode	19
Using Optional Heart Rate Monitors.....	19
General Maintenance	19
General Display Information.....	20
Exploded Diagram.....	21
Parts List	22

Safety Precautions

This exercise equipment was designed and built for optimum safety. However, certain precautions apply whenever you operate a piece of exercise equipment. Be sure to read the entire manual before assembly and operation of this machine.

Also, please note the following **safety precautions**:

1. Read all instructions carefully before using the machine.
2. Consult your physician or other health care professional before beginning this or any type of exercise program.
3. Always wear proper exercise apparel when using the machine.
4. If at any time you feel faint, light-headed or dizzy while operating the machine, stop exercise immediately. You should also stop exercising if you are experiencing pain or pressure.
5. Keep children and pets away from the machine while in use.
6. Only one person can use the machine at a time.
7. Make sure your machine is correctly assembled before you use it. Be sure all screws, nuts, and bolts are tightened prior to use and retighten periodically.
8. Do not operate this or any exercise equipment if it is damaged.
9. Keep hands and feet away from any moving parts. Do not insert any objects into any openings.
10. Keep clothes, jewelry and loose items away from moving parts.



**NOTE: MAXIMUM WEIGHT CAPACITY FOR THE
PHYSIOSTEP LXT IS 400 LBS. (182 KGS)**

WARNING:

BEFORE BEGINNING ANY EXERCISE PROGRAM CONSULT YOUR PHYSICIAN. THIS IS ESPECIALLY IMPORTANT FOR INDIVIDUALS OVER THE AGE OF 35 OR PEOPLE WITH PRE-EXISTING HEALTH PROBLEMS. READ ALL INSTRUCTIONS BEFORE USING THIS FITNESS EQUIPMENT. WE ASSUME NO RESPONSIBILITY FOR PERSONAL INJURY OR PROPERTY DAMAGE SUSTAINED BY OR THROUGH THE USE OF THIS PRODUCT.

Dear Valued Customer,

Thank you for your recent purchase of the **PhysioStep LXT** from HCI Fitness. We believe that you have purchased one of the highest quality and affordable recumbent steppers on the market today. Prior to using your new **PhysioStep LXT** please review the operators manual and product tips to maximize your workout experience.

Wishing you the best of luck in reaching your health and fitness goals!

HealthCare International is a leading supplier and distributor of innovative products for Health, Wellness, Fitness & Active Aging. Visit our website – www.HCIFitness.com for information on all of our products.

Warranty Information

(Your Serial Number is found on a white sticker at the rear base of the unit, the front of the user manual, and on the box)

Serial #:_____ **Purchase Date:**_____

3 Year Parts Warranty, One Year Labor, Lifetime Main Frame

NOTE

Before you start to assemble this unit, please note that some of the parts and screws needed for assembly are already in place on the unit.

TOOL SET:

Tool	QTY
(125) 5mm Allen Wrench Tool	1
(126) Extended 6mm Allen Wrench Tool	1
(127) 13*15 Screwdriver/Wrench Combo Tool	1

Assembly Instructions

STEP 1:

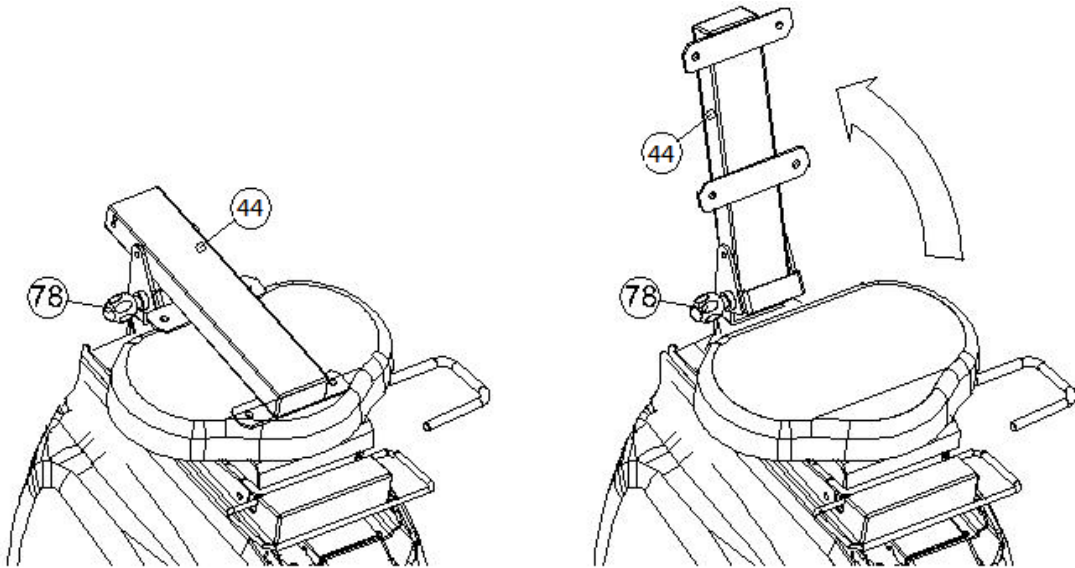

Hold Knob (78) and pull to release the Back Cushion Support (44). Place it in an upright position. Make sure the Knob (78) is then fixed firmly back in place to secure the Back Cushion Support (44).

STEP 2:

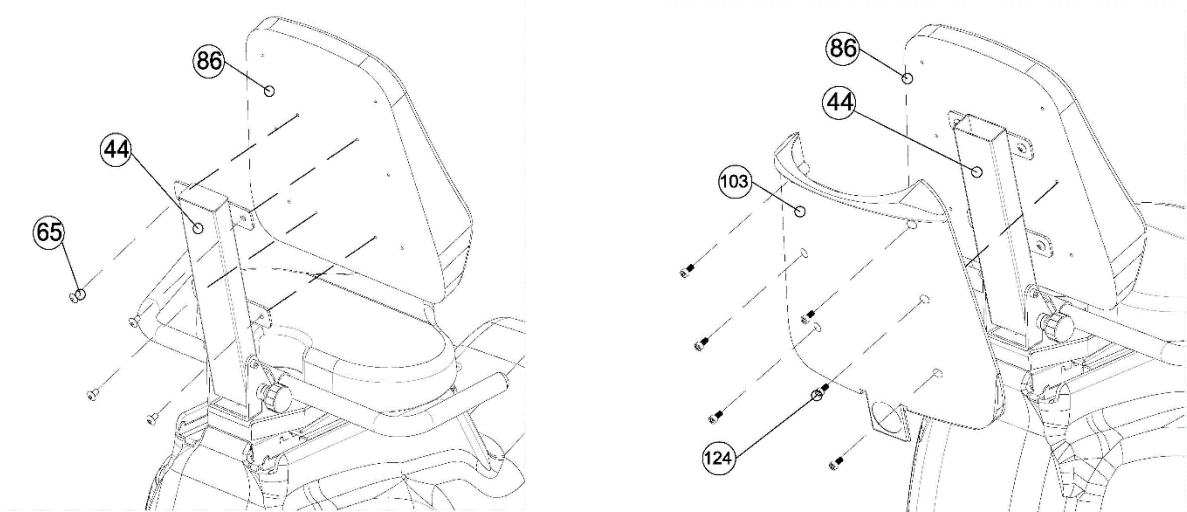

Assemble the Back Cushion (86) by using the Hexagonal Bolt M8*15L (65) to secure the Back Cushion Support (44). Put the seat back cover (103) that is appended to the seat back (86). Using the bolts (124) secure in place. Make sure the bolts are securely tightened.

STEP 3:

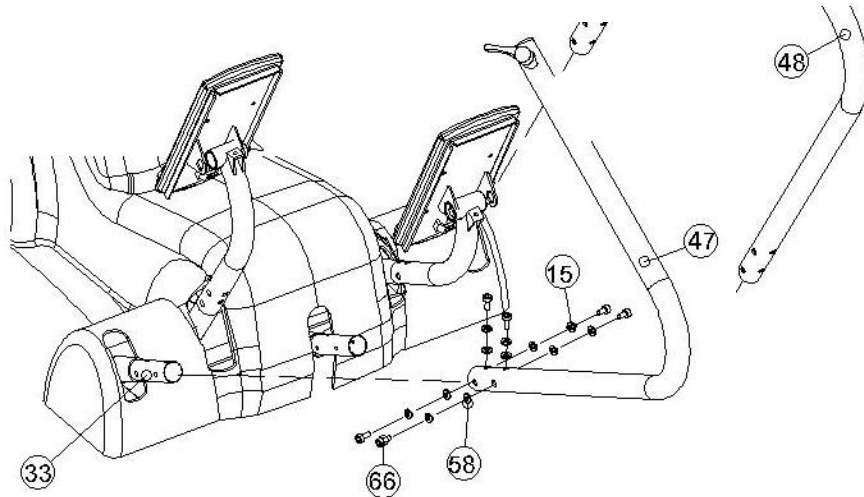

1. Install Moving Handle R (47) to Moving Handle Axis R (33) by using the Hexagonal Bolt M8*15L (66), Spring Washer SW8 (15) and Curved Washer Ø8.5*Ø22*1.5T (58). **Make sure the bolts are securely tightened.**
2. Install Moving Handle L (48) to Moving Handle Axis L (33b) by using the Hexagonal Bolt M8*15L (66), Spring Washer SW8 (15) and Curved Washer Ø8.5*Ø22*1.5T (58). Make sure the bolts are securely tightened.

STEP 4:

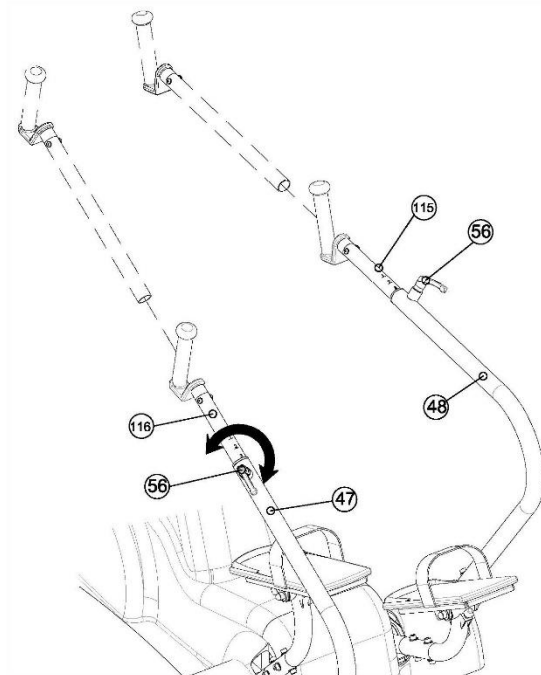

Release Knobs (56) and then insert Moving Handle Set L (116) into Moving Handle R (47) and Moving Handle L (115). Tighten the Knob (56) according to user preference. The Handles can be adjusted to various users' lengths.

STEP 5:

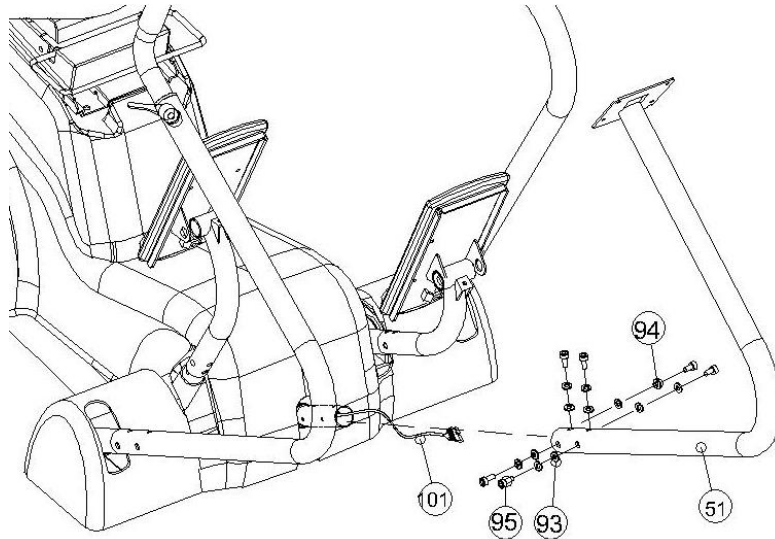

Taking Control Wire (101) feed it through the Computer Post (51). Next, attach the Computer Post (51) to Main Frame (2) using the Curved Washer $\text{\O}6.2*\text{\O}13*1\text{T}$ (93), Spring Washer SW6(94) and Hexagonal Bolt M6*10L (95). Make sure the bolts are securely tightened.

STEP 6

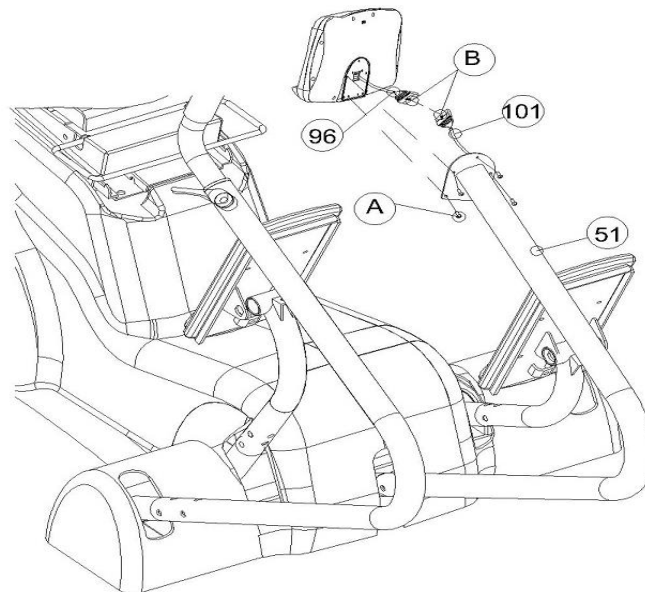

Remove Bolts M5*10L(A) from the back of the Computer (96). Connect Control Wire Computer (B) to the Control Wire (101). Then using Bolt M5*10L(A) attach the Computer (96) to Computer Post (51). Make sure the bolts are securely tightened.

Quick Tips

AC Adaptor:

The **PhysioStep LXT** does need to be plugged into a standard electrical outlet. The AC adaptor connects at the rear base of the unit, at ground level, on the end of the unit that is beneath the seat. The display is powered by the adaptor and does not need batteries.

Levelers:

There are levelers in the front of the unit, beneath the shroud. Please adjust the levelers to stabilize the unit on your floor.

Seat Adjustments:

The **PhysioStep LXT** seat position can be adjusted forward and backward by pulling the long yellow bar located under the seat. The handle on the left of the seat allows the seat to swivel for easy access. In addition you can adjust the tilt of the **PhysioStep LXT** seat back by pulling the knob located on the back cushion support.

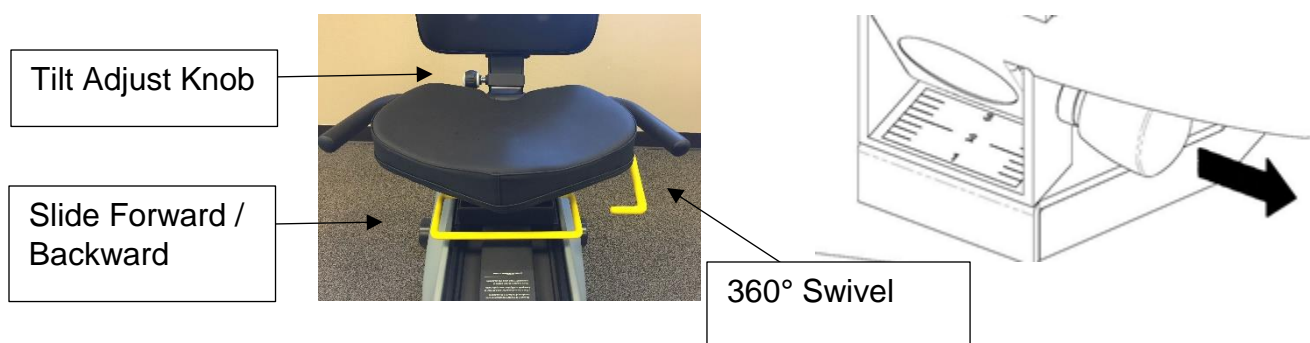

Quick Start:

If you would like to start a simple workout, press the Start Button and use the arrows to set the resistance. It will automatically start you at level 1.

Heart Rate:

If you would like to monitor your heart rate while using the **PhysioStep LXT**, simply use any chest belt. There is a wireless heart rate receiver in the display and it will automatically connect with all common brands of chest belts (i.e. Polar, Garmin etc). If you don't already have one, local sporting goods stores are a good place to purchase. The FT1 is one model that works well.

USB Workout Summary Report:

The **PhysioStep LXT** features a USB workout summary report. The USB slot is located on the back of the display. Simply insert a USB into the back of the display before you start your work out and press the **REPORT** button when you are finished with your workout. Please view **page 17** for more detail.

The USB workout summary feedback reports total time, total calories, total distance, as well as Averages and Peaks for METS, WATTs, Heart Rate, Steps Per Minute, and Speed

PhysioStep LXT Display Console

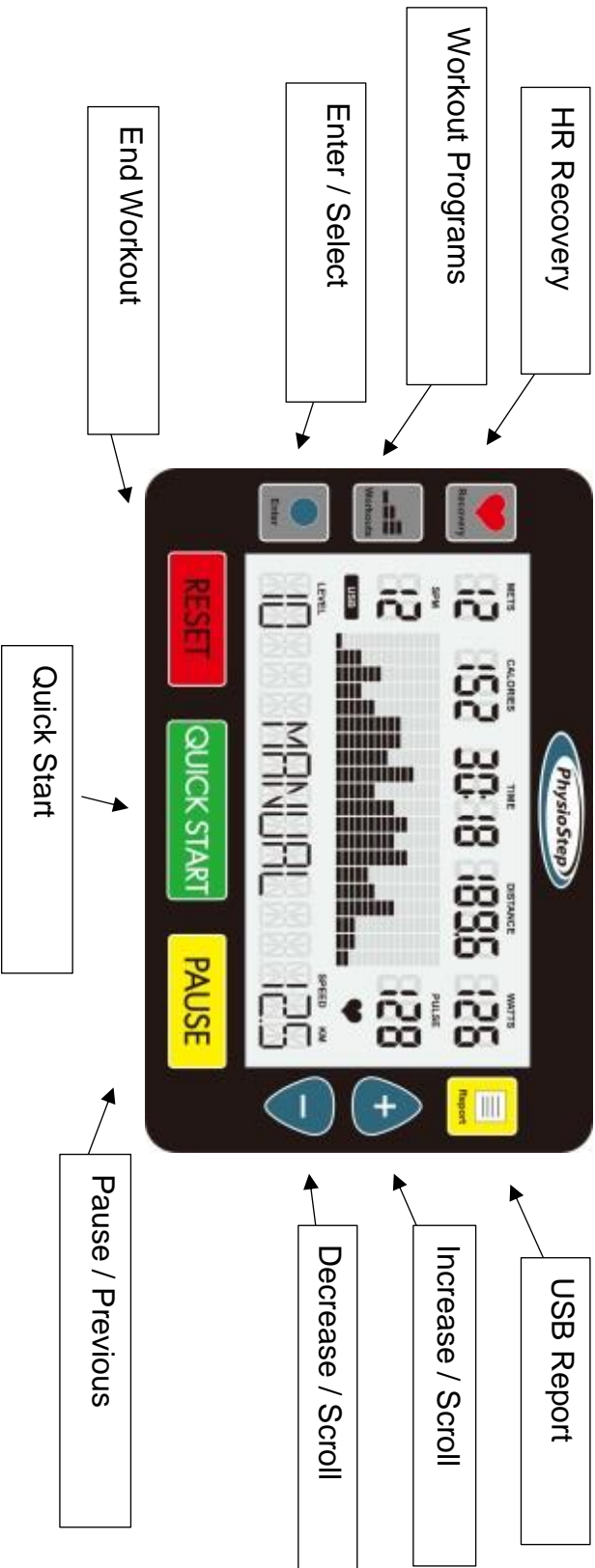

Button Functions

1. QUICK START BUTTON

1.1. Pressing the **QUICK START** button starts a manual workout.

2. ENTER BUTTON

2.1. The **ENTER** button selects programs and confirms data entry.

3. [+] / UP BUTTON

3.1. Press the **[+]** button to increase values.

3.2. Holding the **[+]** button will rapidly increase values.

4. [-] / DOWN BUTTON

4.1. Press the **[-]** button to decrease values.

4.2. Holding the **[-]** button will rapidly decrease values.

5. WORKOUTS BUTTON

5.1. Before you start your workout, press the **WORKOUTS** button to choose a preset program. Continue to press the **WORKOUTS** button to cycle through the programs.

5.2. If you have already started a workout, press **RESET** twice then use the **WORKOUTS** button as explained above.

6. RECOVERY BUTTON

6.1. The recovery function is only available when using a HR monitor.

6.2. Press the **RECOVERY** button to enter the cool down mode.

6.3. When in the recovery mode, all other buttons are disabled.

7. PAUSE BUTTON

7.1. While exercising press the **PAUSE** button to pause your workout. The display will show "*Press QUICKSTART to resume or RESET for workout summary*".

7.2. Press the **QUICKSTART** button to resume your workout.

7.3. Press the **RESET** button to view your workout summary.

7.4. In the Report Mode, the **PAUSE** button will return you to the last step.

8. RESET BUTTON

8.1. To end your workout and view your workout summary press the **RESET** button.

8.2. Holding down the **RESET** button for 3 seconds will reset the display.

9. REPORT BUTTON

9.1. Enables the USB workout report export function in summary mode.

Quick Start –Sit, Start, & Step!

1. Adjust your seat and handles to a comfortable position allowing your legs and arms to use the full range of motion.
2. Press the **QUICK START** button.
3. Start Stepping! You can use **[+]** / **[-]** buttons to adjust the resistance level at any time during your workout.

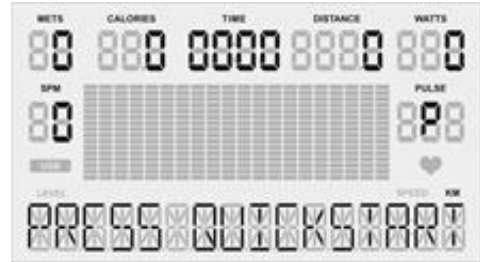

OR

Select a Workout Program

1. Press the **WORKOUTS** button to view programs.
2. To scroll through the different programs, continue to press the **WORKOUTS** button.
3. Then press the **Enter** button to select your desired workout program.
4. Follow the steps described in the next section to start your desired workout.

*If you have not selected anything after 5 minutes the display will automatically power off.

Setup your Workout Programs

Before starting your workout make sure that your seat is comfortably adjusted.

NOTE: Use the **WORKOUTS** button to cycle through programs. Press the **WORKOUTS** button again to view the next workout. Press **ENTER** to select your desired workout.

User Setup:

After selecting your desired workout the first step is to enter your user information. This step will be the same for all workouts.

Use the **PAUSE** button to return to the previous step when entering user info.

Gender: Use the **[+] / [-]** buttons to change Male (**M**) or Female (**F**).

Press the **ENTER** button to set gender.

Age: Use the **[+] / [-]** buttons to change your age.

Press the **ENTER** button to set age.

Weight: Use the **[+] / [-]** buttons to change your weight.

Press the **ENTER** button to set weight.

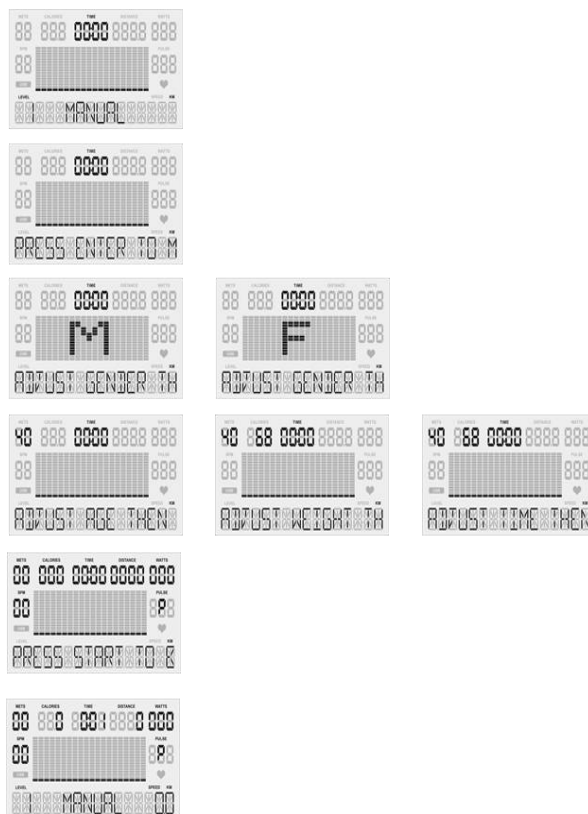

1. Basic Programs

Manual, Warm Up, Interval, Valley, Ramp, Mountain, Rolling, Climb, Random, Hill, Fat Burn, Cardio, and Strength.

1.1. **User Setup** - You will be prompted gender, age, weight, and time.

Use the **PAUSE** button to return to the previous step when entering user info.

1.2. **Set Time:** Use the **[+] / [-]** buttons to set workout time. (Counting Down)

1.2.1.1. Press the **ENTER** button to set workout time.

1.3. Once your user information has been entered press **Quick Start!**

1.4. In the basic programs you can use the **[+] / [-]** buttons to change the resistance level.

1.5. Once your workout is complete a 3 minute Cool Down will begin.

Basic Programs Screens

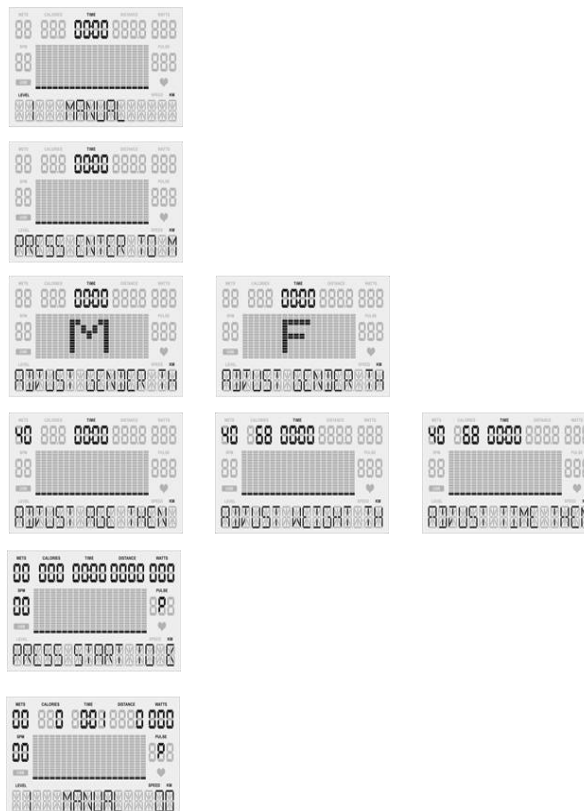

2. Heart Rate Programs (HR 65% / HR 85%) *Requires HR Monitor

2.1. **User Setup** - You will be prompted gender, age, weight, time, & HR.

Use the **PAUSE** button to return to the previous step when entering user info.

2.1.1. **Set Time:** Use the **[+] / [-]** buttons to set workout time. (Counting Down)

2.1.1.1. Press the **ENTER** button to set workout time.

2.1.2. **Pulse:** Use the **[+] / [-]** buttons to change your target heart rate.

(Shown as percentage [65% or 85%] of full target heart rate)

2.1.2.1. Press the **ENTER** button to set your target heart rate.

2.2. Once your user information has been entered press **Quick Start!**

2.3. If your heart rate cannot be detected, the screen will show [? ♥] and reset to the home screen.

2.4. In the Heart Rate programs your resistance level will automatically increase or decrease to help reach your target heart rate.

2.5. Once your workout is complete a 3 minute Cool Down will begin.

Heart Rate Programs Screens

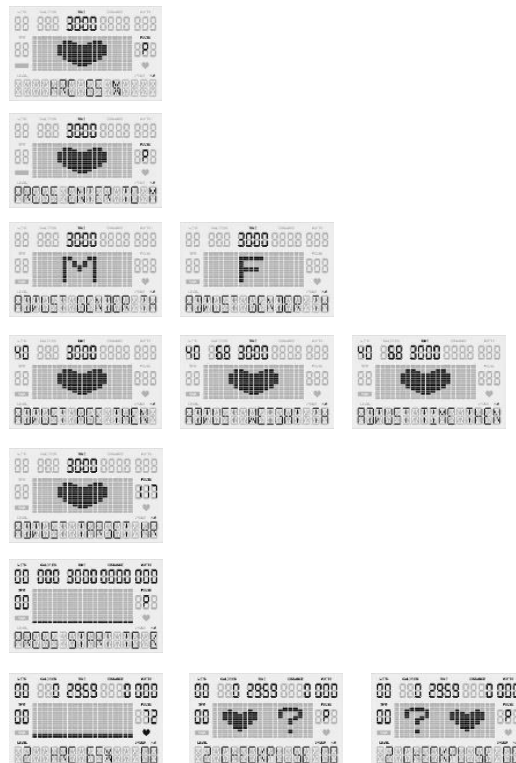

3. Constant Programs (SPM / WATTS)

3.1. **User Setup** - You will be prompted gender, age, weight, time & constant.

Use the **PAUSE** button to return to the previous step when entering user info.

3.1.1. **Set Time:** Use the **[+] / [-]** buttons to set workout time. (Counting Down)

3.1.1.1. Press the **ENTER** button to set workout time.

3.1.2. **Set SPM / WATTS:** Use the **[+] / [-]** buttons to change your constant metric.

3.1.2.1. Press the **ENTER** button to set your constant metric.

3.2. Once your user information has been entered press **Quick Start!**

3.3. If you are not using the machine, the screen will show "[?] Check SPM"

3.4. In the constant programs your resistance level will automatically increase or decrease to maintain constant SPM or WATTS.

3.5. Once your workout is complete a 3 minute Cool Down will begin.

Constant Programs Screens

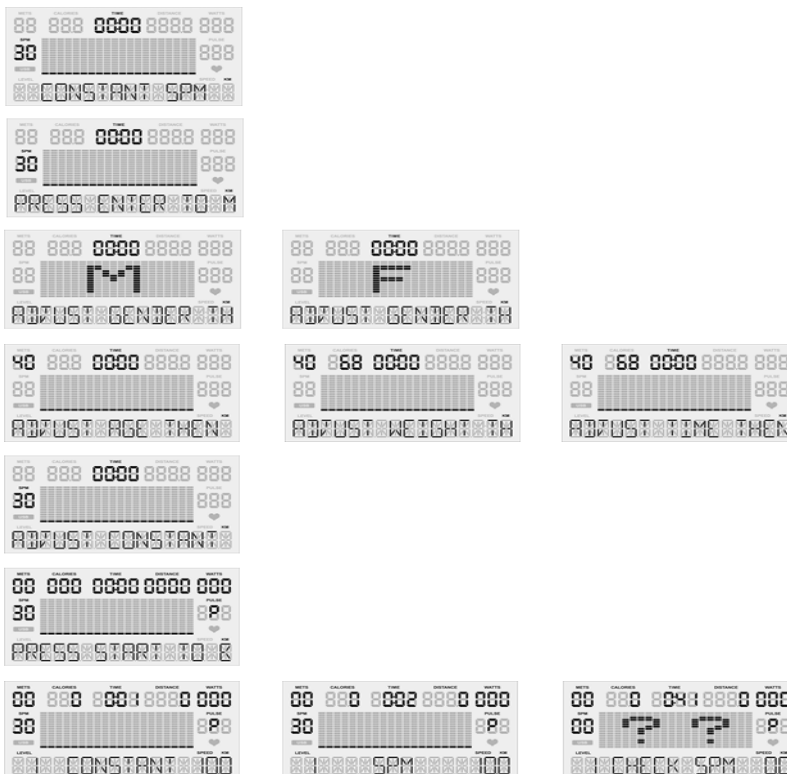

4. Goal Set Programs (Calories / Distance)

4.1. **User Setup** - You will be prompted gender, age, weight, time, & goal.

Use the **PAUSE** button to return to the previous step when entering user info.

4.1.1. **Set Time:** Use the **[+] / [-]** buttons to set workout time. (Counting Down)

4.1.1.1. Press the **ENTER** button to set workout time.

4.1.2. **Set Calories / Distance:** Use the **[+] / [-]** buttons to change your goal.

4.1.2.1. Press the **ENTER** button to set your goal.

4.2. Once your user information has been entered press **Quick Start!**

4.3. In the Goal programs your workout will complete once your goal is reached. Use the **[+] / [-]** buttons to change the resistance level.

4.4. Once your workout is complete a 3 minute Cool Down will begin.

Goal Set Programs Screens

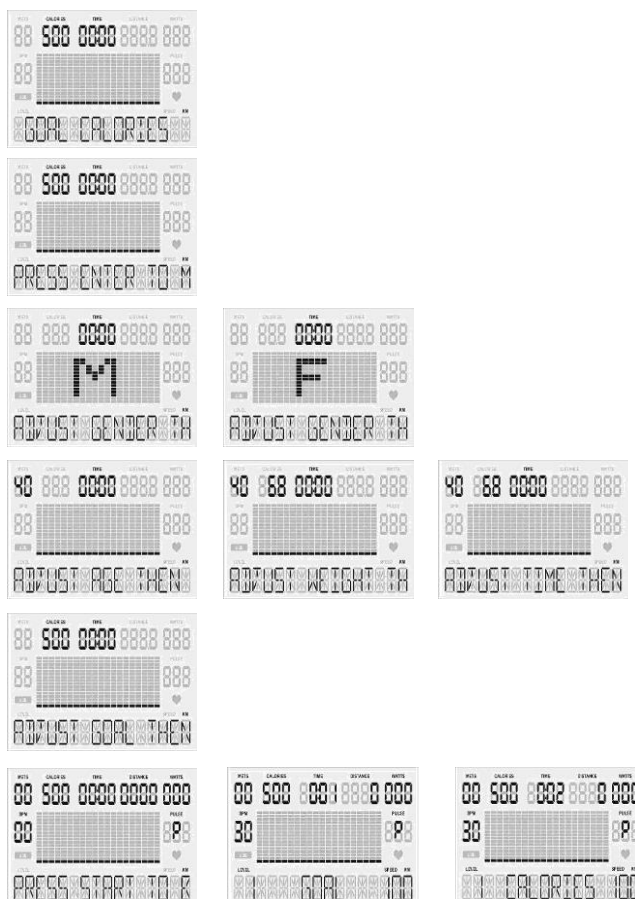

Cool Down Mode

1. After completing your workout program a **3 minute cool down** will automatically start.
2. Press the **PAUSE** button to pause your cool down, and **QUICK START** to resume your cool down.
3. Press the **RESET** button to skip the cool down and view workout summary.

Workout Summary Mode

** After cool down mode, the display shows workout summary**

1. The workout summary mode displays your personal data as shown below:
Total Time, Distance and Calories; as well as Average METs, WATTS, Steps per Minute (SPM) and Pulse.

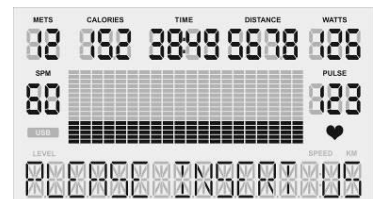
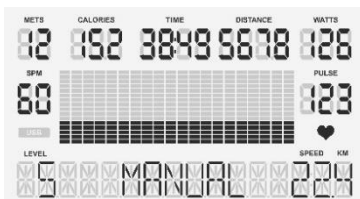

Export Workout Summary to USB –Pause, Reset, Report

USB Slot Located on Back of Display

1. Insert your USB into the USB slot on the back of the display.
2. When the USB is correctly inserted the display will show the symbol “USB.”
3. When you have completed your workout and are on the Workout Summary Mode screen, press the **REPORT** button to begin the export process.
4. Press the **ENTER** button twice to set your Workout ID.

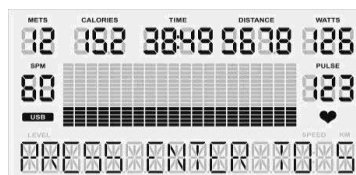
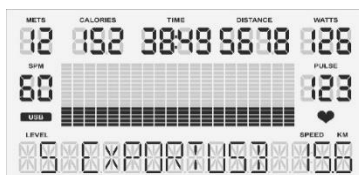

5. Use the **[+] / [-]** buttons to scroll through values (a-z and #0-9). Press the **ENTER** button to select a value and move to the next space.
6. Set your ID by pressing the **ENTER** button until you reach the last space.

PLEASE NOTE: At any time you can press **PAUSE** to return to the previous step.

- After you have set your personal ID, press **ENTER** to select the date (Day / Month / Year). Use the **[+] / [-]** buttons to scroll through the values [a-z and #0-9]. Once the date is selected, press the **ENTER** button to confirm and complete.

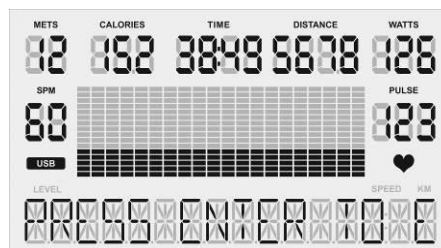
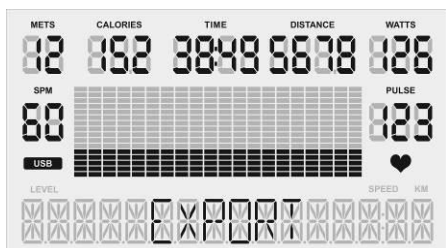

- Once the date is complete, the display will show the messages “*Export*” and “*Press Enter to Export Data*”. Press the **ENTER** button to export your workout summary report to USB. Saving your workout summary will take a few seconds.
- Your workout summary report will be saved in a .csv file that you can open in excel. The display will read “*Complete*” when it has been exported successfully.
- If there is an error during the data export, the display will read “*Error.*” If this happens, press the **PAUSE** button to return to the previous step and export again.

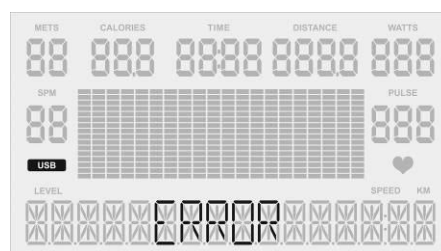
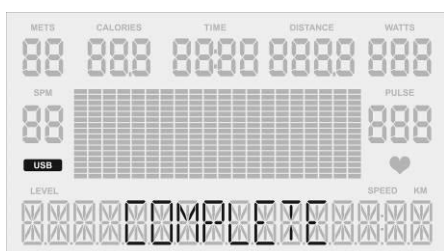

Sleep Mode

- If you do not use the unit for five minutes the display will automatically power off.
- In sleep mode, the LCD monitor will be powered off; any buttons or USB functions will be disabled.
- To wake the unit – start using the machine again and it will power on.

Recovery Mode

**Requires HR Monitor*

1. At any time during a workout program you can press the **RECOVERY** button to enter the recovery mode to see how quickly your body returns to its resting heart rate.
2. Once in the recovery mode the user's peak heart rate is displayed on the top left with the active heart rate below. You will have 1 minute to monitor your heart rate in recovery mode.
3. When the recovery is complete, the screen will display: Excellent (F1.0), Very Good (F2.0), Good (F3.0), Satisfactory (F4.0), Sufficient (F5.0) or Fail (F6.0) based on the rate of recovery.
4. P0 = the user's heart rate when the recovery mode was initiated.
P1 = the user's heart rate after completing the recovery mode.

Using Optional Heart Rate Monitors

1. Chest Strap
 - 1.1. In order to insure the chest strap is working correctly please refer to the manufacturer's instructions. In general, the chest strap must remain wet to accurately work. Moistening the electrodes is very important. Be sure to fasten the strap correctly below your pectoral muscle.

General Maintenance

1. **Cleaning** - Use soap and warm water or antibacterial wipes to clean your unit.
2. **Tightening** - Periodically inspect your unit to insure that all screws, nuts, and bolts are tightened and retighten if necessary. Do not over tighten.

General Display Information

1. Gender

1.1. Men are MALE, Women are FEMALE (preset value is MALE).

1.2. The display shows [M] / [F] when setting.

2. Age

2.1. The age range is between 10 and 99, preset value is 40 years old.

2.2. Age is shown in the top left of the display in the METS window.

3. Weight

3.1. The weight range is between 40 – 400 lbs (30 – 180 KG), preset value is 150 lbs (68 KG).

3.2. Weight is shown next to age in the calories window.

4. Target Heart Rate (THR)

4.1. Using the Heart Rate Control (HRC) programs the user can train at 65% or 85% of their target heart rate.

4.2. When setting age in the Heart Rate Control programs, the computer will calculate a proposed target heart rate for the user. The target heart rate shown on the screen is a percentage (65% or 85%) of your full target heart rate. You can adjust your target heart rate using the **[+]** / **[-]** buttons and set your desired target heart rate by pressing **ENTER**.

4.3. Target Heart Rate Formula = $(220 - \text{AGE}) * X\%$

NOTE: Target Heart Rate Function is only available when using a HR monitor.

5. Pulse

5.1. When using a heart rate monitor, your heart rate will show in the pulse window on the right side of the display. If your heart rate cannot be detected, the pulse window will show (_P_).

6. Units

6.1. Miles are denoted as M, Kilometers are denoted as KM. Preset value: **M**

6.2. To change units please view the Change Units Section on page 21

7. METs

7.1. The Metabolic Equivalent of Task (MET), or simply metabolic equivalent, is a physiological measure expressing the energy cost of physical activities and is defined as the rate of energy consumption during a specific physical activity.

7.2. The range of METs is between 1 – 3 and displays on the top left.

8. Steps Per Minute (SPM)

8.1. Calculates your steps per minutes based on your revolutions per minute (RPM). Steps per minute are shown on the left of the display.

Exploded Diagram

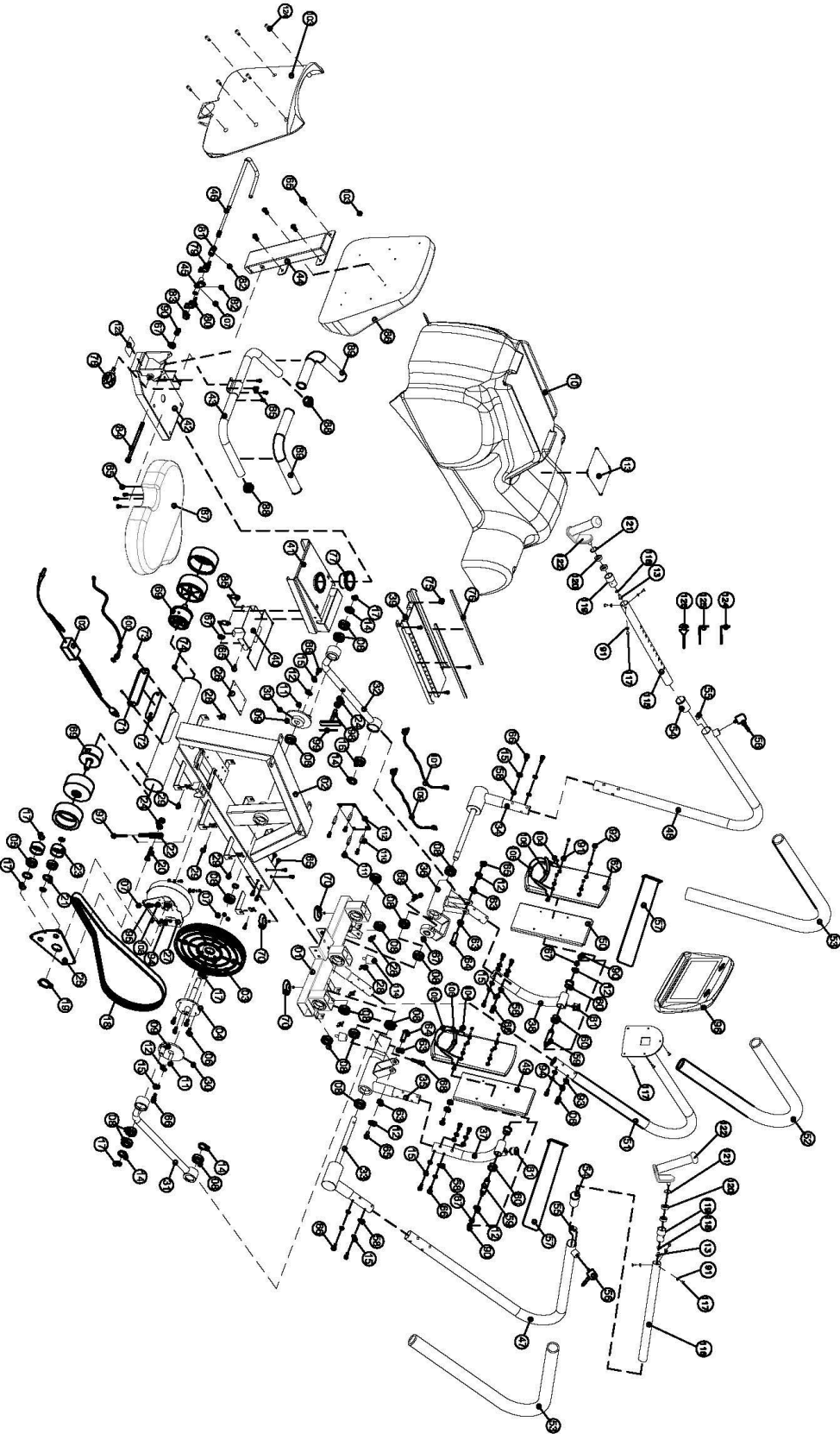

Parts List

No.	Description	Qty	No.	Description	Qty
1	Front Frame	1	30	Stoppage Screw M5*5	5
2	Main Frame	1	31	Connecting Parts (R)	1
3	Belt Pulley	1	32	Connecting Parts (L)	1
4	Pulley Axle	1	33	Moving Handle Axis(R)	1
5	Ball Bearing 6204ZZ	2	34	Moving Handle Axis (L)	1
6	Hexagonal Bolt M6*15L	12	35	Moving Pedal Set (R)	1
7	Lock Nut M6	8	36	Moving Pedal Set (L)	1
8	Ball Bearing 6004ZZ	16	37	Pedal Foot (R)	1
9	Eccentric Wheel	2	38	Pedal Foot (L)	1
10	Chain Cover	1	39	Change pipe	1
11	Button 5*5*15L	2	40	Dipping Handle	1
12	Washer Ø8.5*Ø26*1T	8	41	Seat Moving Set	1
13	Hexagonal Bolt M8*15L	2	42	Rear Stabilizer	1
14	C-ring R-42	4	43	Seat Handle	1
15	Spring Washer SW8	30	44	Back cushion support	1
16	Spherical bearing	2	45	Files block	1
17	C-ring S-20	8	46	Dipping Handle	1
18	Belt	1	47	Moving Handle (R)	1
19	C-ring S-40	1	48	Moving Handle(L)	1
20	Hexagonal Bolt M6*20L	1	49	Pedal (R)	1
21	C-ring R-47	2	50	Pedal (L)	1
22	Metal Parts	1	51	Computer Post	1
23	Idler Wheel Ø53*Ø43*24	2	52	Handle Sponge	1
24	Screw Nuts (M6)	3	53	Handle Sponge	2
25	Idler Support	1	54	Place control	2
26	Control Board	1	55	Hand fixed block	2
27	Magnetic Flywheel- EMS	1	56	Knob	2
28	Screw Hole Clip	12	57	Pedal Strap	2
29	"+" Bolt ST4*12L	12	58	Curved Washer Ø8.5*Ø22*1.5T	28

No	Description	Qty	No.	Description	Qty
59	Shaft For Pedal Bracket	2	92	Hexagonal Bolt M6*25L	8
60	Bushing	4	93	Curved Washer	8
61	Rubber Cushion	2	94	Spring Washer SW6	12
62	Pedal	2	95	Hexagonal Bolt	4
63	Bushing-Ø25*Ø18*8.5L	4	96	Computer	1
64	Axle	2	97	Adjusting Bolt	1
65	Hexagonal Bolt M8*15L	2	98	Tension Cable	1
66	Hexagonal Bolt M8*15L	2	99	Square Magnet	4
67	Nylon Nut M8	9	100	Power inlet	1
68	Hexagonal Bolt φ10*50L	2	101	Control Wire	1
69	Rear Leg Wheel	2	102	Adapter	1
70	Adjustment Fix Cushion (28*11)	3	103	Back Cushion Cover	1
71	Socket Cover	1	104	"+" Bolt ST5*30L	8
72	Input Socket	1	105	Ankle Support Bolt	2
73	Screw M5*8L	2	106	Ankle Support	2
74	"+" Bolt ST5*12L	2	107	Stoppage Screw	1
75	Hexagonal Bolt M8*12L	4	108	Hexagonal Bolt	4
76	Moving Plastic Post	2	109	Control Wire	1
77	Bushing	1	110	Plastic pillars	4
78	Knob M16*P1.5*25L	1	111	Plastic screws	4
79	Clockwise Spring-R	1	112	Control Board	1
80	Chemistry Spring-L	1	113	Non-Slip footpad	1
81	Compass Tube	1	114	Rubber Cushion	2
82	Stoppage Screw M6*6	2	115	Rotatable Moving	1
83	Nylon Nut M10	1	116	Rotatable Moving	1
84	Hexagonal Bolt M8*100L	1	117	"+" Bolt ST5*30L	11
85	Spring	2	118	Washer d8*D16x1.5t	2
86	Back Cushion	1	119	Bearing Base	2
87	Seat	1	120	2 way bearing 6001zz	4
88	End Cap	2	121	R-ring R28	2
89	Handle Sponge	8	122	Rotatable Handle	2
90	Nut Cover M8	5	123	Seat Indicator	1
91	Washer Ø6.2*Ø13*1.2T	14	124	Hexagonal Bolt M8*15L	6