

# PhysioGait

Dynamic Unweighting Systems

## PhysioGait Owner's Manual V2.1



HealthCare International

[www.HCIFitness.com](http://www.HCIFitness.com)

360-321-7090 or 800-398-9121



# Table of Contents

1.	Introduction	3
2.	Characteristics of Dynamic Unweighting Device	4
	2.1. Intended Use	4
	2.2. Technical Parameters	5
3.	Construction and Assembly of PhysioGait	6
	3.1. Construction Component Elements	6
	3.2. PhysioGait Assembly	7
4.	Safety Precautions	10
5.	Preparation for Use	10
6.	Operation Steps	12
	6.1. Height Adjustment - Raising / Lowering Yoke	13
	6.2. Adjusting the Dynamic Partial Weight Bearing Yoke	13
	6.3. Adjusting the Swivel Yoke	13
	6.4. Locking Castors / Direction of Travel	14
	6.5. Mounting the Straps to Slings - Harness	15
	6.6. Mounting the Harness to PhysioGait	17
	6.7. Adjustment - Changing Handrails	18
	6.8. Adjusting Swivel Yoke	20
	6.9. Installation and Adjustment of Operator's Stool	21
	6.10. Checking Battery Status	21
	6.11. Charging the Battery	22
	6.12. Emergency Stop Button	23
	6.13. Wireless Weighing Module	24
	6.14. GaitScale Operation	25
	6.15. Charging GaitScale Battery	28
7.	PhysioGait Operating Conditions	29
	7.1. Cleaning Patient Contact Surfaces	29
	7.2. Maintenance of Support Structure Mechanism	29
	7.3. Inspection of the Column	30
	7.4. Periodic Inspections of Electrical Safety	30
8.	Warranty Card	31

# 1. Introduction

Congratulations on your excellent choice of the PhysioGait Dynamic Unweighting Device.

The PhysioGait Dynamic Unweighting Device is characterized by stability, reliability and ease of use. This results from its ingenious design, technology of manufacturing and product quality assurance system. Reading the instruction manual will allow such operation of the PhysioGait Dynamic Unweighting Device to ensure its safe and long term use. Please note the serial number on the last page of the manual. You can find your serial number on the outside of the original packaging.

## General Considerations:

1. The product should be operated by qualified and trained personnel who are familiar with the contents of this manual.
2. Use, operation and maintenance of the product in a manner inconsistent with this manual is not permitted and can lead to damages, for which the manufacturer shall not be liable.
3. If the performance and parameters of the product are inconsistent with the description contained in this manual, do not use the product. You must immediately report it to the manufacturer or supplier.
4. Any repair of the product must be performed by the factory or authorized service and registered in the list of repairs attached to the warranty card. Failure to do so will void the warranty of the product.
5. Technical description of the lift with a list of spare parts and their replacement methods is available from the manufacturer on request.

Warranty terms will not be respected if the user uses the product in a manner inconsistent with its intended purpose or does not respect the terms of use stated in this manual.

The manufacturer shall not be liable for the consequences of improper (inconsistent with the conditions set out in this Manual) use of PhysioGait Dynamic Unweighting Device!



### ATTENTION!

In this manner are indicated activities, which if performed inconsistently with the instruction manual may cause deterioration of conditions or safety hazard to the user and / or personnel operating the device.



Such marking is applied on the table where it is essential to read the contents of the Operation Manual and follow its instructions when using the table.



Type B Application Part



Manufacturer



Risk of head injury



Load of the device



Actuator operation type



Direct current

## 2. Characteristics of Dynamic Unweighting Device

### 2.1. Intended Use

PhysioGait Dynamic Partial Weight Bearing system is intended to accomplish dynamic patient support used in the rehabilitation and gait reeducation. The device is used for therapeutic and diagnostic purposes (training balance and gait). It is ideal for working with neurological and orthopedic patients, both adults and children.



PhysioGait Dynamic Unweighting Device with the equipment has been made in compliance with the essential requirements for medical devices and has a CE marking, according to manufacturer declaration.



### ATTENTION!

The manufacturer reserves the right to make such changes, non-exposed in the current version of the manual that do not cause deterioration of the functional parameters and conditions for product safety.



### ATTENTION!

Trained personnel decides on legitimacy of the use of PhysioGait Dynamic Unweighting Device for handling the patient.

## 2.2. Technical Parameters





Device parameters		PhysioGait
Depth	up to	53" (135 cm)
Outside Width of Base	PG-360 L	35.4" (89.9 cm)
	PG-360 XL	39" (99 cm)
Inside Width of Base	PG-360 L	30.7" (78 cm)
	PG-360 XL	34.3" (87 cm)
Height adjustment	minimum	4'9" (145 cm)
	maximum	7' 9" (236 cm)
Patient height	minimum	-
	maximum	7' 2" (218 cm)
Patient Height on 6" Treadmill	maximum	6'8" (203 cm)
Operation mode		Discontinuous with short-term load (10%) max. 2 minutes operation (ON), min. 18 minutes pause (OFF)
Load of the device		≤ 360 lbs. (163.3 kg) (symbol indicates the maximum safe load of the device when lifting or lowering the arm)
Unit Weight		220 lbs. (100 kg)
Max Weight of Operators Stool	Maximum	220 lbs. (100 kg)
Electrical supply and safety precautions	voltage	24 V  (battery supply)
	application part	type B, 
Ingress protection		IP40
safety precautions (temperature, relative humidity, pressure)	operation	50 F to 104 F (+10 C to +40 C), from 30% to 75% without condensation, 700-1060 hPa
	storage	41 F to 113 F (+5 C to +45 C), does not exceed 75% without condensation, 700-1060 hPa
	transportation	14 F to 113 F (-10 C to +45 C), from 20% to 95% without condensation, 700-1060 hPa

Table 1 - Technical parameters of PhysioGait Dynamic Unweighting Device

### 3. Construction and Assembly of PhysioGait

#### 3.1. Construction Component Elements

##### ATTENTION!



It is strictly forbidden to modify the device without written authorization of the Manufacturer! The construction of PhysioGait Dynamic Unweighting Device is made of a steel powder coated frame, which is attached to the body of the lifting column which is made of durable aluminum alloy. The construction of the device consists of the following units:

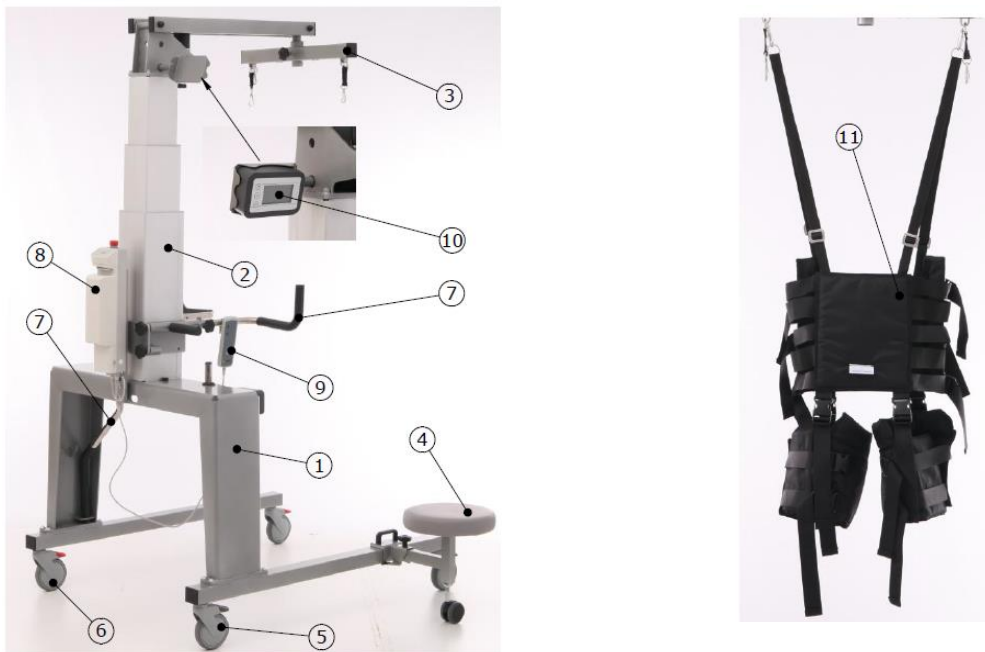

Figure 1 - Construction elements of PhysioGait Dynamic Unweighting Device

1. Base/Frame
2. Actuator Column
3. Yoke Assembly
4. Operators Stool
5. Directional Locking Casters
6. Total Locking Casters
7. Handle Bar Assembly (2 Types Included)
8. Controller Unit
9. Remote Control
10. Wireless GaitScale
11. Harness

**Note:** The components are sent in a box, unassembled and wrapped in protective material. When unpacking, check the components to ensure the components arrived in good condition. Report any faults immediately to HealthCare International.

## 3.2. PhysioGait Assembly

Before assembly, unpack, inspect and prepare all the components. Have the proper hex keys ready (6mm, 4mm, 2.5mm). We recommend that 2 qualified people assemble the PhysioGait as some components are heavy.

1. Connect both sides of the wheel base to the support frame as shown. Ensure that the wheel bases are parallel.

Check if the span between both sides is the same at both ends.

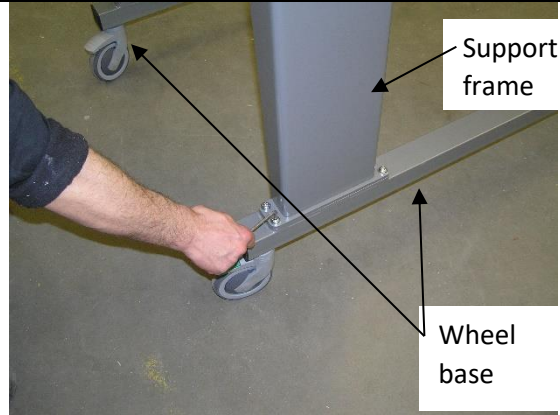

2. Connect the column to the support frame. Make sure the wires leave the column at the same side as the two holes in the support frame marked with the eye symbol (  ).

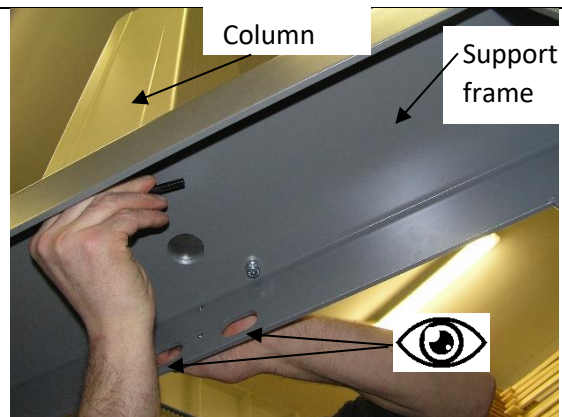

3. Fix the yoke assembly to the actuator column. The yoke assembly points to the side of the unit with the PhysioGait unit away from the control unit.

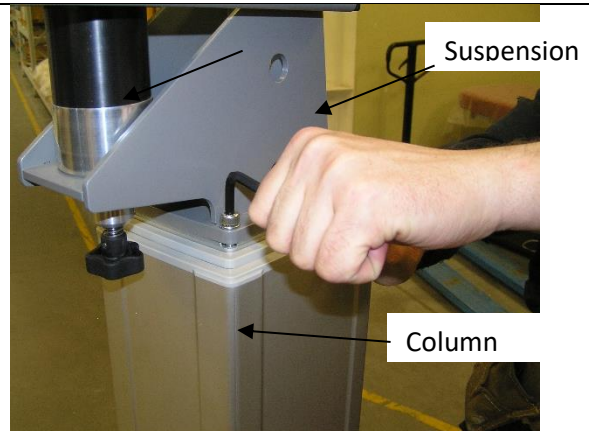

4. Install the controller assembly mount to the support column placing the distance washers provided between the controller mount and the support frame.

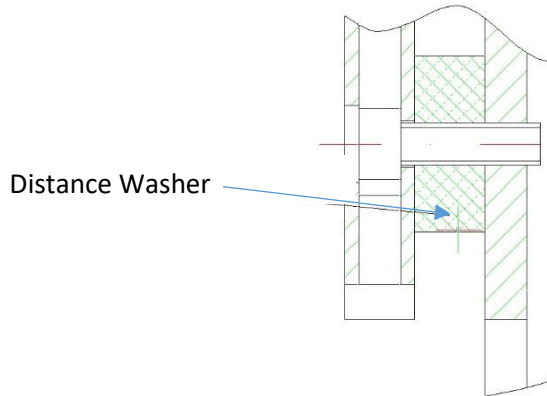

5. Attach the controller to its mount and put the battery in.

Be sure to tighten the screw so that the battery docking station is securely mounted to the unit.





6. Fix the sliding handle bar assembly to the column.

Make sure all the black glide disks are placed inside the handle bar assembly (16 pcs).



7. Fix the remaining components such as the remote controller and magnetic display to the display mount.



## 4. Safety Precautions



### ATTENTION!

PhysioGait Dynamic Unweighting Device has a limited ability to load up!  
The patient's weight at lifting-lowering as well as during the partial weight bearing should not exceed 360 lbs (164 kg).



### ATTENTION!

Do not allow controller mounted on the column to contact (flooding) with liquid (e.g. Coffee tea, water, cleaning agents and disinfectants).



### ATTENTION!

The system uses a special harness to support the patient. It is important that the harness is properly fitted to the patient.

Before starting the procedure, you should facilitate the attachment of the harness to device by lowering the arm to the bottommost position and locking the castors. Similarly, after the completion of the session, you should facilitate the removal of the harness by locking the castors and lowering the weight bearing arm to the bottommost position. The manufacturer shall not be liable for the consequences of improper (inconsistent with the conditions set out in this Manual) use of PhysioGait Dynamic Unweighting Device!

## 5. Preparation for Use



### ATTENTION!

Do not use the device in an environment where other devices, where energy emission results from the other devices normal operation. The PhysioGait's lifting system and panel during normal operation, as any electronic device generates, uses, and can emit radio frequency energy. If the device is not installed and used in accordance with the instructions, it may cause harmful interference to other devices in the vicinity. Manufacturer of the device does not guarantee that interference will not occur even in special location. To verify if the device is a source of interference to other devices, you must change its position. You can try to correct the impact of the interference by the following: change the orientation or location of the device, increase its distance in relation to interfered device and consult a service unit.

**ATTENTION!**



When determining or changing the place of use of the PhysioGait Dynamic Unweighting Device you should pay particular attention to ensure that the space under the frame is free from any items. You should prevent uncontrolled access to the place of use of the device by children and pets (cat, dog, etc.).

**ATTENTION!**



The device may not be operated in rooms with high relative humidity, especially in rooms intended for hydrotherapy treatments.

1. The operation location of partial weight bearing Dynamic Unweighting Device should be chosen so that to ensure a minimum 2.6" (80 cm) gap on the outside of each side of the unit and enough space in front and behind the device to enable free movement. The device should be placed and used only on hard, horizontal and level surfaces.
2. After the initial placement of the partial weight bearing Dynamic Unweighting Device it should be unpacked from transport the packaging. The PhysioGait Dynamic Unweighting Device is ready for assembly.

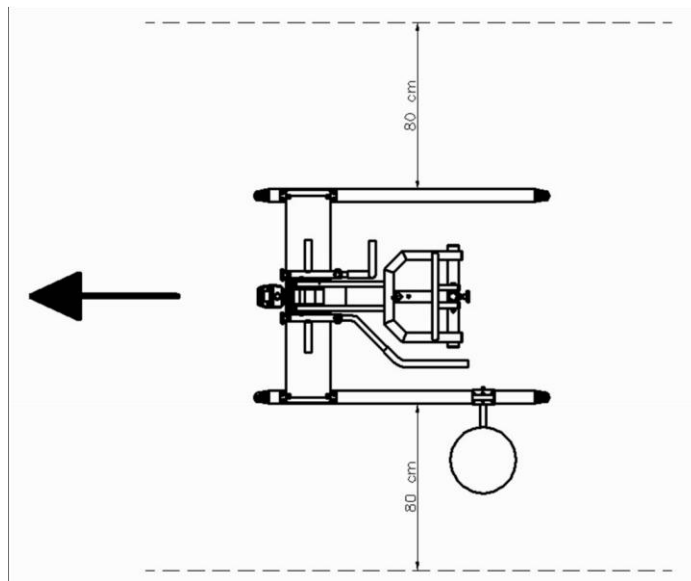

**Figure 2 - The recommended location of PhysioGait Dynamic Unweighting Device**

## 6. Operation Steps



### **ATTENTION!**

Always maintain a safe distance from the lifting mechanism operating during the height adjustment. The movable parts of this mechanism present a risk of crushing.



### **ATTENTION!**

Always secure the device against movement. Wheel brakes should be released only during gait therapy.



### **ATTENTION!**

Conducting gait therapy on a treadmill requires all four castors to be locked!



### **ATTENTION!**

Operating personnel must be present at all times during therapy and monitor its progress!



### **ATTENTION!**

In the event of a malfunction or deviations from normal operation, stop rehabilitative activities on PhysioGait Dynamic Unweighting Device and the contact PhysioGait service department!



### **ATTENTION!**

In order to ensure safe operation, maintain a minimum ceiling height of at least 8' (244 cm)



### **ATTENTION!**

Risk of head injury!

Before starting operation of PhysioGait Dynamic Unweighting Device you should always lock the wheels. The patient should be dressed in suitable clothing to perform procedures. Clothes made of synthetic materials, thick and rough fabrics or any other thick fabrics is not recommend.

## 6.1. Height Adjustment - Raising / Lowering Yoke

In the Dynamic Unweighting Device height adjustment is done with the remote control. Simply press the (▲ - up / ▼ - down) button on the remote control to raise and lower the yoke height. Always verify clearance when raising and lowering the Yoke height. After reaching the extreme maximum and minimum height, column drive switches off automatically.

## 6.2. Adjusting the Dynamic Partial Weight Bearing Yoke

Adjust from a rigid yoke to flexible yoke with the twist of a knob (Fig 3). The PhysioGait Dynamic Unweighting Device is equipped with a dynamic partial weight bearing system. Adjustable characteristics of the weight bearing arm movement enables the simulation of yoke mobility in the range of 0 – 4.9" (0-12.5 cm). To adjust the dynamic partial weight bearing, to be suitable for each patient you should turn the adjusting screw. Turn the knob to the right to increase the rigidity of the adjustable yoke and turn the knob to the left to increase flexibility.



*Figure 3 - Adjusting dynamic partial weight bearing system*

## 6.3. Adjusting the Swivel Yoke

Loosen the locking swivel yoke knob to release the swivel yoke. The swivel yoke can be left unlocked for ambulatory rehabilitation exercises or locked in place for sideways gait training.



## 6.4. Locking Castors / Direction of Travel



### ATTENTION!

Locking the castors prevents the rotation of the device during gait training, but does not protect against castors slipping on the ground. The device should be placed and used only on horizontal and level surfaces away from the longitudinal slides, stairs, etc.



### ATTENTION!

Directional wheels should be locked after determining the direction of the Dynamic Unweighting Device.

PhysioGait Dynamic Unweighting Device is equipped with four castors. The two castors on the left side are equipped with directional lock (green brake mechanism), while the two castors on the right side with a full lock (see Fig. 4). the sequence of setting the directional lock:

- ① Set the device in the space provided to carry out the gait therapy.
- ② Set the device in such a way that the castors line up parallel to the axis of the device, in accordance with the travel direction.
- ③ Lock directional castors.
- ④ Castors with full lock are not blocked.
- ⑤ PhysioGait Dynamic Unweighting Device is ready for safe forward movement.
- ⑥ In the return direction, unlock the directional wheels and repeat steps ①-⑤, ensuring the wheels move in the right direction along with the device.



**Figure 4 - Location of the castors in PhysioGait Dynamic Unweighting Device**

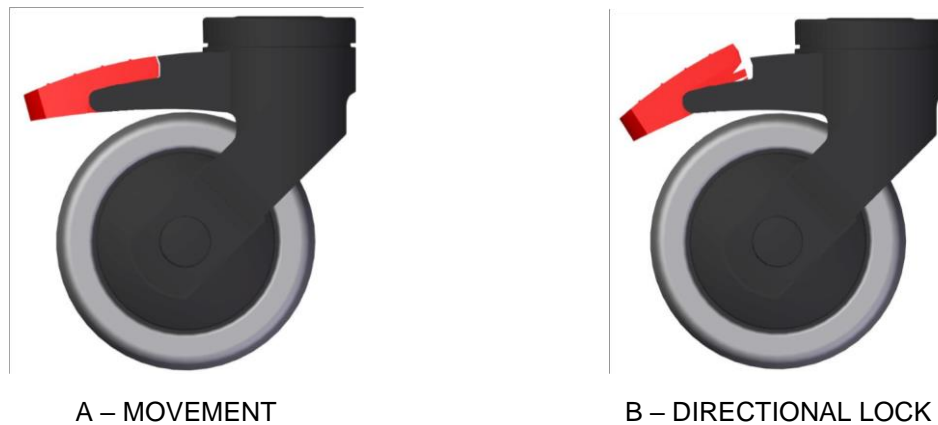

**Figure 5 - Directional lock of the castors in the frame**

## 6.5. Mounting the Straps to Slings - Harness



### ATTENTION!

Only harnesses distributed by HealthCare International can be used with the PhysioGait. The Harness should be used according to the manufacture's guidelines.

Straps for suspending the patient - harness (see Fig. 6) are used for stable fastening as well as supporting the patient during gait training. Prior to the session you should select and individually adjust the straps for each patient. Strap fasteners should be mounted with a slight play - the width of the palm, in order to pull it up later on adjusting elements. The pads sewn into the straps improve patient comfort during gait training.



*Figure 6 - The harness for suspending patient to PhysioGait Dynamic Unweighting Device*

**Fastening harness in the supine position:**

- ① Place the patient on his back.
- ② Place one end of the harness in the middle abdomen.
- ③ Turn the patient to left or right side.
- ④ Place the harness on the back of the patient so that the straps with hooks have an equal length in relation to the axis of the spine.
- ⑤ Place the lowest strap of the harness at the height of the great trochanter of the femur.
- ⑥ Pull the inguinal straps between the legs, fasten strap buckles in front of the harness.
- ⑦ While holding the harness turn the patient on his back.
- ⑧ Fasten front mounting buckles.
- ⑨ Check if the harness is located symmetrically with respect to the axis of patient's body - adjust the position of harness if necessary.
- ⑩ Tighten the inguinal straps evenly and as far as possible.



- ⑪ After tightening the remaining straps, the harness is ready for use with the PhysioGait Dynamic Unweighting Device.

#### **Fastening the harness in upright position:**

- ① Place the harness on patient's torso.
- ② Place the lowest strap of the harness at the height of the great trochanter of the femur.
- ③ Fasten front mounting buckles.
- ④ Tighten front straps.
- ⑤ Pull the inguinal straps between the legs, fasten strap buckles in front of the harness.
- ⑥ Check if the harness is located symmetrically with respect to the axis of patient's body - adjust the position of harness if necessary.
- ⑦ Tighten the inguinal straps evenly and as far as possible.

### **6.6. Mounting the Harness to PhysioGait**

#### **ATTENTION!**



Before each session, check the condition of the harness. Any damage to the harness or any part of it, disqualifies the harness from further use!

#### **ATTENTION!**



When mounting the harness on the swivel sling it is not possible to display indication of the load on the panel. Indications are displayed when the harness is suspended on the PhysioGait yoke.

The harness is attached over the patient's head by the clip on the harness straps (see Fig. 7). Suspension of the harness can be done directly on the weight bearing arm or on the swivel sling.



Figure 7 - Mounting the harness to the weight bearing arm

Mounting the harness to PhysioGait Dynamic Unweighting Device:

- ① Lock the castors.
- ② Adjust harness mounting height to the weight bearing arm about 4" above the patient's head.
- ③ Adjust the length of the upper harness straps ensuring free reach to the grips on the weight bearing arm.
- ④ Place the clips on the locking tabs of the yoke.
- ⑤ Tighten upper straps all the way.
- ⑥ Once the patient is in the mounted harness the device is ready for use on a solid ground or in cooperation with a treadmill.

## 6.7. Adjustment - Changing Handrails



### ATTENTION!

Rigidly lock the handrail in the mounting hole. It is not allowed to block the railing by just inserting the pin through mounting holes – the pin should be further secured by tightening!

PhysioGait Dynamic Unweighting Device is equipped with adjustable and interchangeable rails for supporting the patient during gait training (see fig. 8).



*Figure 8 - Handrails for PhysioGait Dynamic Unweighting Device*

Handrails can be adjusted in accordance with the mounting holes in handrail profile (see Fig. 9). To change the handrail or the position of the handrail remove the retaining pin by unscrewing and removing it from the retaining hole. After changing the type or location of the handrail, lock the retaining pin by inserting and tightening it in the fixing hole (see Fig. 10).



*Figure 9 - Example of handrail mounting in PhysioGait Dynamic Unweighting Device*



Figure 10 - Correct lock of the handrails in mounting holes

You can adjust the height of the handrail to the individual patient's height. To do this, loosen four locking knobs, located on both sides of the controller (see Fig. 11), set the desired height of the handrail and lock the locking knob in a way that ensures support of the handrail under the load.

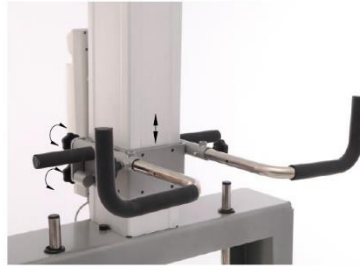

Figure 11 - Adjusting the height of the handle bar mount

## 6.8. Adjusting Swivel Yoke

PhysioGait Dynamic Unweighting Device is equipped with an additional swivel yoke to lift the patient (see Fig. 12). Additional yoke is used to change the movement of the device along with the patient. Range of rotation is 0-90°. In order to change the position of the rotary sling loosen the locking knob, turn the swivel yoke to the left or right (as needed) by 90° angle and lock the position by tightening the locking knob.

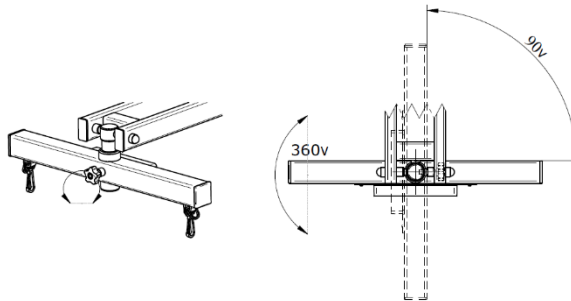

Figure 12 - Adjusting the swivel yoke

## 6.9. Installation and Adjustment of Operator's Stool



After mounting or changing the position of the stool, block the position lock.

In order to improve ease of use of PhysioGait Dynamic Unweighting Device, there is a possibility of mounting a stool at one of the beams of the frame. The stool can be moved along the rail, which allows optimal adjustment of the position for individual needs. The stool installation requires no tools. The stool arm mounted on the supporting wheel is fixed to the frame beam with a magnetic lock and safety lock. To move the stool, release the safety lock and pull the handle, to determine new position then lower the handle. The magnetic lock works automatically then the safety lock should be engaged (see Fig. 13). The wheel under the stool is used to adjust the position against the ground. If necessary, unscrew the knob or screw, until the optimal alignment of stool arm.



Figure 13 – Installation and adjustment of operator's stool

## 6.10. Checking Battery Status

Checking battery status (see Fig. 14) is carried out by a visual inspection of the indicator icon on the remote control panel.

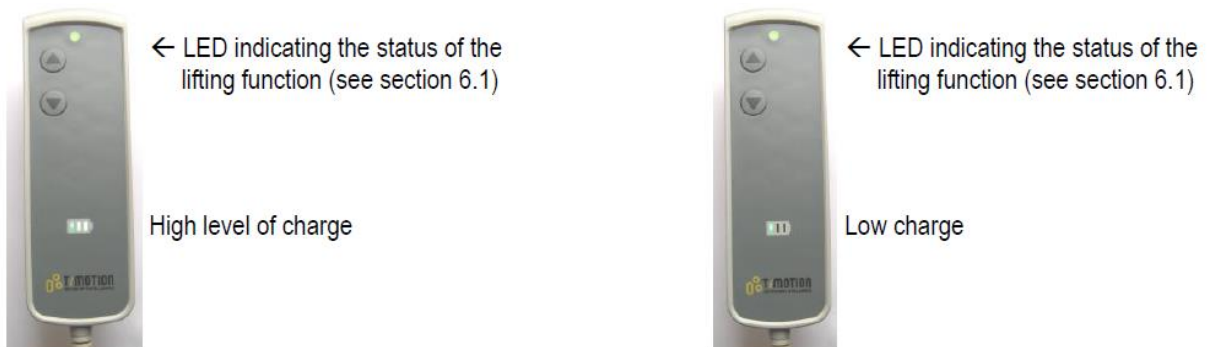

Figure 14 - Checking the battery charge level

## 6.11. Charging the Battery



### ATTENTION!

After each finished charging, disconnect the power supply from the wall socket, and the battery from the docking station.

Battery charging (see Fig. 15) is possible with the use of a dedicated docking station and power supply purchased with the Dynamic Unweighting Device. In case of lack of power supply from the battery, release the battery by pressing the lock, remove it from the body of the controller and fit it in the dock. Docking station must be connected to the power supply, which must be connected into the power outlet 100-240 VAC 50/60 Hz. Charging status is indicated by indicator located on the power supply: Charging (yellow), Charging finished (green). The light on the docking station is a power indicator. After removing the battery from the docking station you should put it back in the controller housing in a manner ensuring locking of the mounting hitch.



*Figure 15 - Charging and handling the battery*

## 6.12. Emergency Stop Button



### ATTENTION!

After each finished session, press the lock button preventing the use of Dynamic Unweighting Device powered stroke control function.

PhysioGait Dynamic Unweighting Device is equipped with an emergency stop button (see Fig. 16).



*Figure 16 – Emergency Stop Button*

Adjustment function is locked when the power lock button ① is pressed. Control function is enabled when the power lock button is not pressed ①. Lock release is done by turning the button ① in direction as indicated on its surface.

## 6.13. Wireless Weighing Module

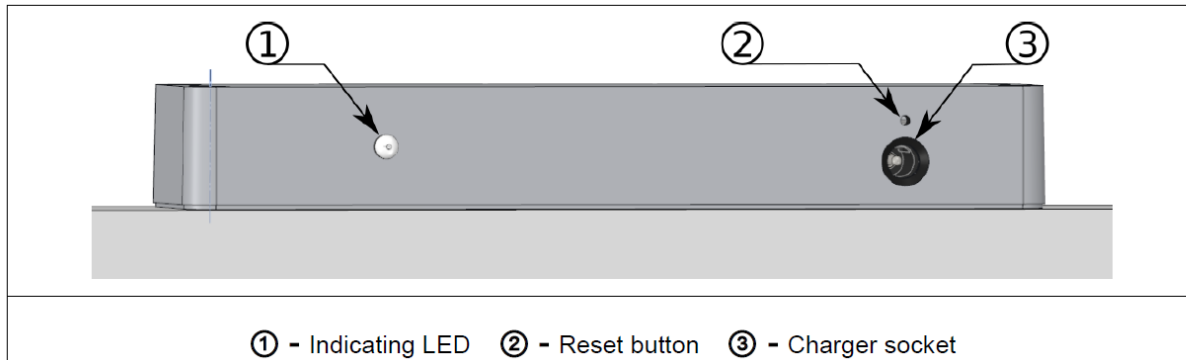

Figure 17 – Weighing Module

### Description of the Weighing Module Functions

<b>Turning the Weighing Module ON/OFF</b>	The weighing module is switched on by changing the load on one of the sides by a minimum of one kilogram for about 1 second. The indicator light flashes with a short pulse twice per second, signaling the wait for the connection to the panel. If the connection is not established within 60 seconds, the device will automatically go into sleep mode. The LED stops flashing.
<b>Connecting the weighing module to the GaitScale</b>	With the GaitScale powered on, simply pull down on the harness to connect the GaitScale and Weighing Module. The connection state to the panel will be signaled by a short pulse diode every 1 second. When the connection is interrupted, the beam will enter the wait for the connection mode, which will be indicated by a diode short pulse of 0.5 second
<b>Low battery</b>	In operation mode, the diode uses green light to indicate the operating status. When the battery level is low, the status light is orange. The weighing module battery level is also displayed on the GaitScale when connected
<b>Resetting the Weighing Module</b>	The RESET button is located on the unit's housing. In case of a problem with the device, use a thin object and press it into the hole.
<b>Charging the Weighing Module</b>	Connect the supplied power cord to the weighing module when the unit is not in use.





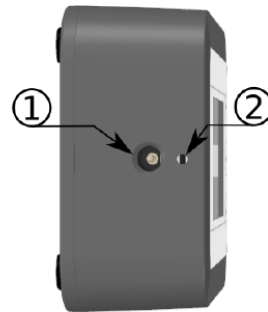





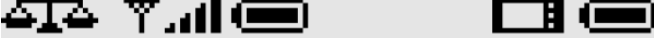

## 6.14. GaitScale Operation

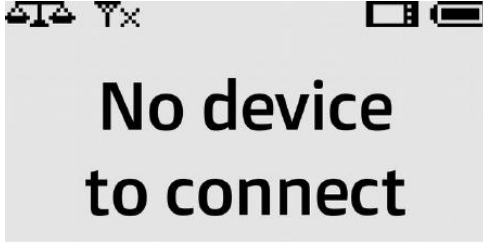

① - Charger socket ② - Reset button

### Description of the GaitScale functions:

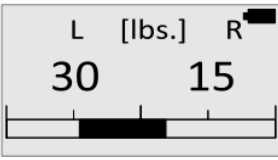
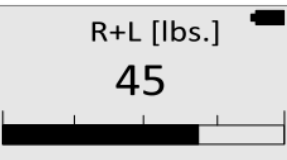
<b>Turning ON the GaitScale</b>	To activate the display, press any button and hold it for more than 0.5 s.
<b>Turning OFF the GaitScale</b>	In case if no button is pressed for the programmed time or the load does not change by 1 lb, the panel will automatically turn off. To immediately switch off the panel from the main screen or connection waiting screen, press and hold the center button for more than 0.5s. or button
<b>Status Bar</b>	 <p>The status bar is always visible at the top of the screen. Indicates the connection status and battery level of the weighing module and operator panel.</p> <p> - symbol of weighing module. The icons on the right apply to the weighing module.</p> <p> -signal strength. When the panel is not connected to the weighing module, the symbol  is displayed and the battery symbol is not visible.</p> <p> - symbol of the battery charge level of the weighing module / operator panel.</p> <p> - operator display symbol. The icons on the right apply to the GaitScale.</p>

<p><b>Connection Screen</b></p>	<p>When the GaitScale and weighing module are turned on, they will try to automatically connect.</p> 
<p><b>Connection Failed</b></p>	<p>If the GaitScale and weighing module connection is not established pull down on the harness to restart the connection.</p>  <p>If you still cannot connect, contact HealthCare International</p>
<p><b>Main Screen</b></p>	<p>On the main screen measured values of weight relief of left and right side are displayed. Graphic indicator shows the measured weight bearing value against programmed patient's weight. Switching between display modes is done by pressing  or .</p>
<p><b>Left and Right Scale</b></p>	<p>Simultaneous weight bearing value on the left and right side is presented.</p> 
<p><b>Total Scale</b></p>	<p>The sum of weight bearing of left and right side is presented.</p> 
<p><b>Differential Scale</b></p>	<p>Difference of weight bearing of left and right side is presented.</p> 

**Peak Unweighting Mode** Pressing the button will activate the peak load relief mode. The display under the battery indicator of the operator's panel displays the symbol. This mode is active in all display modes. To switch off the peak hold mode, press the button again. When the Peak Hold mode is activated, the display shows the highest recorded offload. It will be maintained for the time set in the user settings in *Peak Hold*. The graphical weight bearing indicator will be represented by the current strain weight bearing and additionally, there will be indications of the peak value.





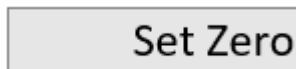











**Reset Scale** Press and hold the middle button on the Rest Screen to Set Zero

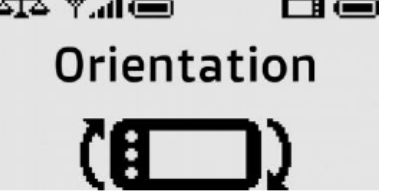

**Configuration of user settings** To change user settings when displaying the main screen simultaneously press and buttons and then hold for more than 0.5s. Switching between positions in the setup menu is carried out by pressing or .

<b>Set Patient Weight</b>	Press  to enter the weight of a new patient, then use the  and  button to set the desired value from 55 to 440 lbs and confirm the setting with .	Patient Weight [lbs.] 100
<b>Change Units</b>	Press  to change the unit, then use  and  button to switch between kilograms and pounds and confirm the setting with .	Weight Unit lbs.
<b>Auto OFF</b>	Press  to change the programmed time, then use  and  to set the desired value from 3 to 60 minutes and confirm by pressing .	Auto Off [min.] 10

<b>Backlight</b>	Press  to change the brightness of the backlight, then use  and  to set the desired value from 0 (backlight off) to 5 (max brightness) and confirm the setting  .	Backlight [min.] 5
<b>Peak Hold</b>	Press  to change the programmed time, then use  and  to set the desired value between 1 second and 60 minutes. Press and hold the  and  to rapidly change the time.	
<b>Screen Orientation</b>	Press  to change the screen orientation, then use  and  rotate the screen orientation.	
<b>Return to Main Screen</b>	Press  to exit the Setup menu and return to the main screen.	

## 6.15. Charging GaitScale Battery



### ATTENTION!

Do not use the device while charging panel battery.

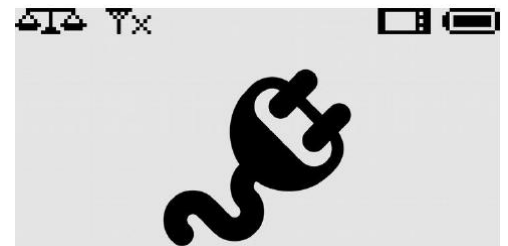

To charge the built-in battery, use the supplied 5V 1A; 100-240V ~ 50 / 60Hz AC power adapter (see Fig. 18). Panel battery charge indicator is placed in the upper left corner of the screen. The jack for connecting the power supply is placed on the rear wall of the panel housing. After connecting DC power supply the built-in battery starts charging automatically, and it continues until the moment when it will be fully charged. The charge status or end of charging is indicated by LED (charging - bright orange, end of charging - blue). The electronics of the monitor shows the battery condition and protects it against improper charging conditions, from overcharging, or over-discharging that can result in damage to the monitor.

## 7. PhysioGait Operating Conditions



### ATTENTION!

Surfaces of the handle and device supporting structure must be prophylactically cleaned and / or disinfected after each use (after every patient) which allows to maintain proper hygiene conditions.



### ATTENTION!

The expected service life of the device is 7 years. After 7 years from the date of manufacture of the device (and its equipment) manufacturer is no longer liable for defects of the device (and its accessories) and the resulting consequences.

### 7.1. Cleaning Patient Contact Surfaces

1. The surface of the handles should be cleaned and maintained as follows:
  - clean regularly with a mild detergent (e.g. soap) in warm water using damp soft cloth or sponge;
  - for large stains rub with a damp soft brush;
  - after cleaning, wipe dry with a soft cloth.
2. Harness for suspending the patient should be cleaned wiped with a mild detergent.
3. Avoid wetting the handle and harness for suspending the patient.
4. Accessible areas of handle and construction can be disinfected using anti-bacterial spray.
5. Do not use:
  - pastes, waxes, sprays;
  - strong detergents, solvents and cleaning agents containing solvents, alcohol and leather cleaning agents.

**The use of such agents can cause stiffness and cracking of the material, as well as changing surface gloss, not covered by the warranty!**

### 7.2. Maintenance of Support Structure Mechanism

1. Metal parts of the structure can be cleaned with a soft, damp cloth. Cleaned surfaces should be wiped dry each time.
2. All the mobile nodes should be (with the exception of the column) lubricated once every six months or when loud noises occur during their work. Such nodes include: -transport wheels axles and handrails.

As a lubricant, we recommend using commercially available penetrating and lubricating formulations. Avoid contact with upholstered surfaces, and any spills of such preparations should be immediately removed with a dry cloth.

3. Periodically - every six months – carry out an inspection of threaded connections and, if necessary, remove the emerging backlash with a cross tip screwdriver with, hex keys (No. 4, 5, 6, 8 and 10, a spanner (17). Such connections include:

- Weight bearing arm screws;
- Lifting column fixing screws;
- Transport wheels fastening screws;
- Screws securing legs stringers in the frame;

Major damage should be reported to the manufacturer service department and operation of unit should cease until the issue is resolved.

### **7.3. Inspection of the Column**

The PhysioGait is equipped with an electric column to change the yoke height. In order to ensure proper operation, quarterly inspect the column to verify it is correctly functioning, including the occurrence of sounds not from normal operation, for example rattles, squeaks, creaks. Detection of any irregularities in the operation of the actuator must be immediately reported to PhysioGait followed by ceasing operation of the device until removal of the causes.

### **7.4. Periodic Inspections of Electrical Safety**

At least once every two years and each time after a service issue or repair of the unit, a technical service provider should perform an inspection of the unit in terms of electrical safety.

The minimum scope of the inspection should include:

- check to ensure there were no mechanical damages of wiring;
- check whether there is any mechanical damages of controller housing, battery and columns;
- check the status of height adjustment function switches.

Inspection should be documented each time with entry in the table on page 27.

***Operating personnel must follow the instructions contained in this manual***



## 9. Exploded Diagrams









22

Parts of the control system and charging

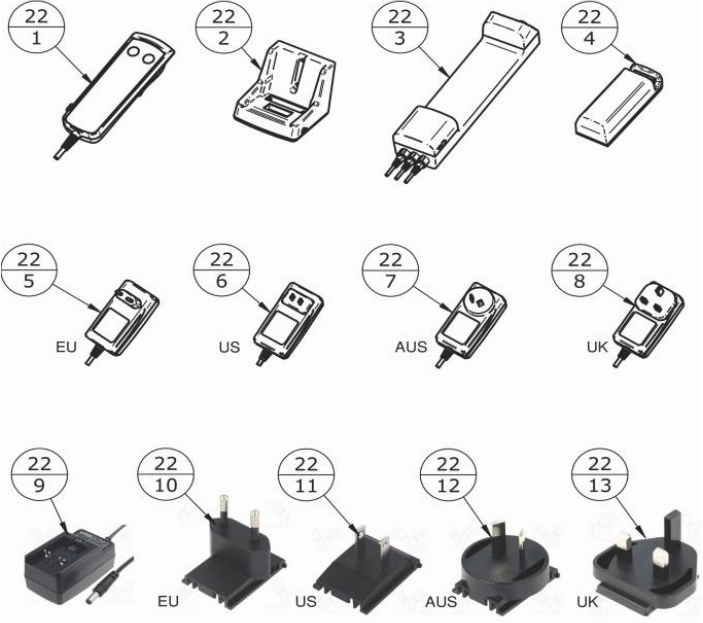

### ACCESSORIES

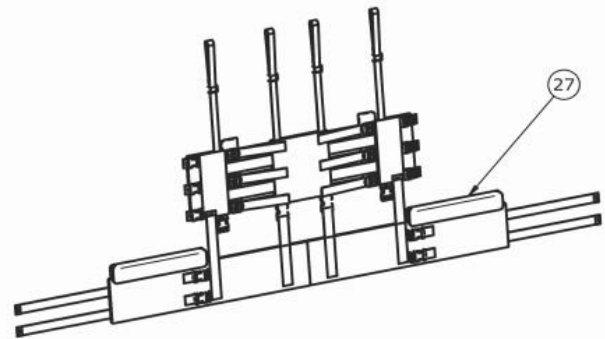
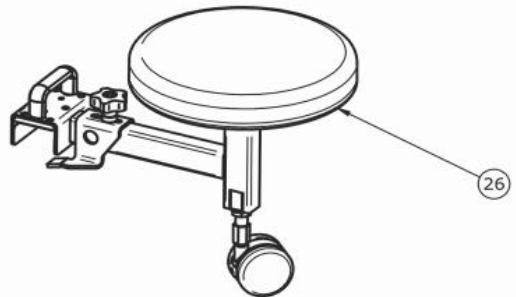

26	02-0100-0000-3794	SEAT
27	02-0100-0000-5839	HARNESS

## 10. Parts List

1	02-0100-0000-5939	SHORT HANDLE RIGHT
2	02-0100-0000-5940	SHORT HANDLE LEFT
3	02-0100-0000-5941	LONG HANDLE RIGHT
4	02-0100-0000-5942	LONG HANDLE LEFT
5	02-0100-0000-3923	BLOCKADE
6	04-3049-1200-0101	KNOB
7	02-0100-0000-3924	KNOB FAST
8	02-0200-0000-0574	DISPLAY
9	04-3070-1200-0081	PLUG
10	02-0200-0000-0528	LOAD CELLS
11	02-0100-0000-3197	HOOK
12	04-3070-1200-0084	PLUG
13	02-0100-0000-4448	SECURITY
14	04-3045-0000-0015	SNAP HOOK
15	02-0200-0000-0575	TRANSDUCER HANDLING MODULE
16	02-0100-0000-3198	SIDESLIP
17	02-0100-0000-3214	ELASTOMER
18	04-3055-0600-0050	WHEELS WITH BRAKE TOTAL
19	04-3070-1200-0086	PLUG
20	04-3055-0600-0051	WHEELS WITH BRAKE UNIDIRECTIONAL
21	04-5012-3300-0066	COLUMNS
22	PAGE 4	CONTROL BOX
23	04-3049-1200-0087	STAR KNOB
24	02-0100-0000-6631	KNOB DISTANCE
25	02-0100-0000-6411	DISPLAY HOLDER

22-1	04-5012-4300-0051	CONTROLS
22-2	04-5012-4300-0097	CHARGING CRADLE
22-3	04-5012-4200-0045	CONTROL BOX without Battery
22-4	04-5012-4300-0041	BATTERY 5Ah
22-5	04-5012-4300-0093	POWER SUPPLY CONTROL BOX EU
22-6	04-5012-4300-0094	POWER SUPPLY CONTROL BOX US
22-7	04-5012-4300-0095	POWER SUPPLY CONTROL BOX AUS
22-8	04-5012-4300-0096	POWER SUPPLY CONTROL BOX UK
22-9	04-2587-1200-0004	POWER SUPPLY DISPLAY
22-10	04-2587-1200-0012	ADAPTER POWER SUPPLY DISPLAY EU
22-11	04-2587-1200-0014	ADAPTER POWER SUPPLY DISPLAY US
22-12	04-2587-1200-0011	ADAPTER POWER SUPPLY DISPLAY AUS
22-13	04-2587-1200-0013	ADAPTER POWER SUPPLY DISPLAY UK

Pair your PhysioGait with the PhysioMill!



**HEALTHCARE**  
INTERNATIONAL

