



# AUGUSTINE TREATMENT RECLINER

## OWNERS OPERATING & MAINTENANCE MANUAL



**PLEASE DO NOT DISCARD THIS MANUAL! KEEP IT FOR FUTURE REFERENCE AND TRAINING.**

# TABLE OF CONTENTS

IMPORTANT SAFETY INFORMATION.....	3-5
ASSEMBLY INSTRUCTIONS.....	6-7
ATTENDANT OPERATING INSTRUCTIONS.....	8-11
OCCUPANT OPERATING INSTRUCTIONS.....	12-13
GENERAL MAINTENANCE.....	14-15
SPECIFICATIONS.....	16
AUGUSTINE CHAIR OPTIONS.....	17
ARM COVER OPTION INSTRUCTIONS.....	18-20
CONTACT & WARRANTY INFORMATION.....	BACK COVER

**Winco assumes no responsibility for damage or injury caused by the improper assembly, installation, use or maintenance of this product.**

## IMPORTANT!





PLEASE READ THIS ENTIRE MANUAL BEFORE USING RECLINER. DO NOT INSTALL, MAINTAIN OR OPERATE THIS EQUIPMENT WITHOUT READING AND FOLLOWING THIS MANUAL. OTHERWISE INJURY AND/ OR DAMAGE MAY RESULT.

THE INFORMATION CONTAINED IN THIS MANUAL IS SUBJECT TO CHANGE WITHOUT NOTICE. PHOTOS ARE REPRESENTATIVE OF THE PRODUCT AND MAY VARY SLIGHTLY FROM ACTUAL PRODUCTION MODELS.

### SAVE THESE INSTRUCTIONS FOR FUTURE REFERENCE!

NO PART OF THIS MANUAL MAY BE DUPLICATED IN ANY FORM WITHOUT THE PRIOR WRITTEN CONSENT OF WINCO MFG, LLC. UNAUTHORIZED DUPLICATION MAY RESULT IN CIVIL PROSECUTION TO THE MAXIMUM EXTENT ALLOWED BY LAW.

**Products with the following markings are intended for commercial use only.**

		100-240 VAC 44W, 50-60Hz	<b>WARNING: Long-term, continuous exposure to heat may cause burns. Read instructions before using. DO NOT use wet. DO NOT insert pins into upholstery.</b>
		Supply: 12V 	
	Operating Conditions:		
	10° - 40° C		

## SYMBOLS



FOLLOW INSTRUCTIONS



DC VOLTAGE



TYPE B APPLIED PART



GENERAL WARNING SIGN



CENTRAL-LOCKING BRAKE



PINCH POINT WARNING SIGN



SYMBOL FOR MANUFACTURER

# IMPORTANT - PLEASE READ



**FOR PRODUCTS WITH POWERED OPTIONS (Heat, Massage, etc...)**

**IMPORTANT SAFETY INSTRUCTIONS - SAVE THESE INSTRUCTIONS**

**(Read all instructions before using this product.)**

**When using an electrical appliance, basic precautions should always be followed, including the following:**

**DANGER** - To reduce the risk of electric shock always unplug this product from the electrical outlet before cleaning, maintenance or servicing.

**WARNING:**

1. Unplug this product from the electrical outlet when not in use.
2. Supervision should be provided when using this product.
3. Use this product only for its intended use as described in this manual.
4. Do not use attachments not recommended by the manufacturer.
5. Never operate this product if it has a damaged cord or plug, if it is not working properly, if it has been dropped or damaged, or dropped into water, contact an authorized Winco service center for instructions.
6. **DO NOT** carry or pull this product by power supply cord or use the cord as a handle.
7. Keep the cord away from heated surfaces.
8. Do not use outdoors.
9. To disconnect, turn all controls to the "off" position, then remove plug from outlet. Pull plug only to remove cord.
10. Clean switch with a damp cloth only – Warranty will be VOID if liquid is introduced into switch mechanism.
11. Extension cords are not recommended.
12. **DO NOT** roll recliner or other equipment over cord.
13. This product is for use on a nominal 120-volt circuit and has a three-pin plug. If the plug does not fit into the outlet, contact a certified electrician to install the proper outlet. **DO NOT MODIFY THE PLUG IN ANY WAY.** No adapter should be used with this product.
14. For an added level of safety; Winco recommends the use of a 120 volt GFCI (ground fault circuit interrupter) outlet.
15. Keep children away from extended foot support (or other similar parts).

**DANGER:**

- i. Never insert pins, or attach other metallic fasteners into/onto any part of this chair.
- ii. Do not use this product if the covering shows signs of deterioration, such as checking, blistering, or cracking.
- iii. **KEEP DRY** - Do not operate in a wet or moist condition or environment.

**WARNING:**

- i. Long term, continuous exposure to heat may cause burns. It is recommended that skin in contact with heated area be checked for redness and blistering during long term usage. Do not use on an infant, invalid or incapacitated person. Do not use on insensitive skin or on a person with poor blood circulation. If you are uncertain if you should use this product, please consult your physician about the use of heat and massage.
- ii. Do Not Crush/Pinch heating elements or wiring.

# IMPORTANT - PLEASE READ

For Heat & Heat and Massage Chairs

This equipment is marked with the industry recognized symbol

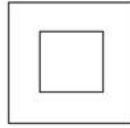

indicating it is a “Class II Double-Insulated” device as defined by IEC 60601-1. As such, it does NOT require a three conductor power cord (i.e. one with a ground connection) for safety purposes. While the equipment can be safely operated with no ground connection, a three conductor power cord is provided to satisfy customer expectations for typical equipment configuration. Devices qualifying as double insulated require different testing & examination procedures than “Class I Grounded” devices. If your facility requires the product to be tested, be sure to follow testing & examination procedures for “Class II Double-Insulated” devices.

ISOLATION DIAGRAM FOR HEAT & MASSAGE SYSTEM

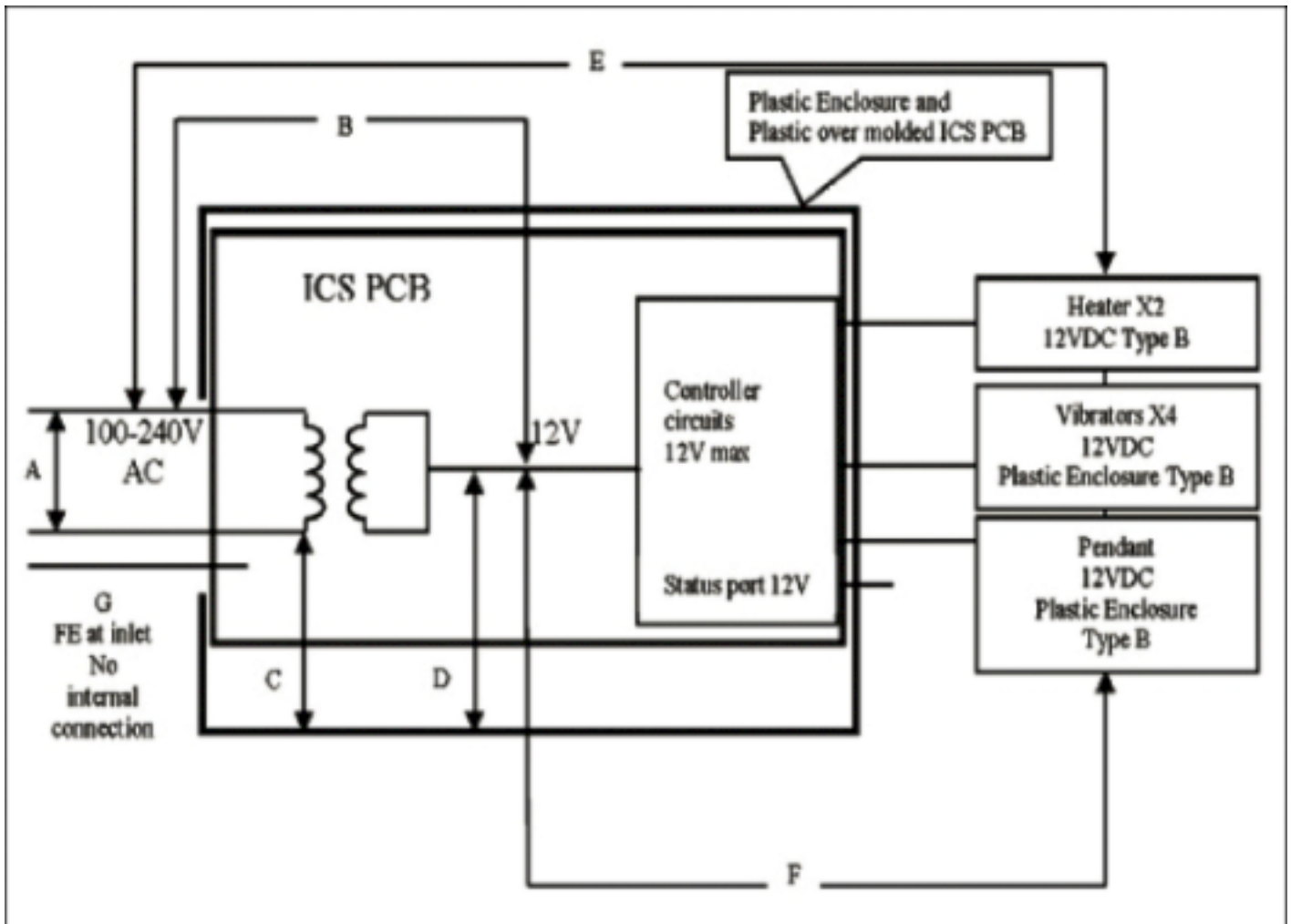

Area	Insulation Type
A	Basic Operational
B	Double Insulated/Reinforced
C	Double Insulated/Reinforced
D	Double Insulated/Reinforced
E	Double Insulated/Reinforced
F	Double Insulated/Reinforced
G	Inlet FE pin only connects to inlet & pad

# IMPORTANT - PLEASE READ

## **BASIC SAFETY PRECAUTIONS:**

1. READ AND FOLLOW ALL DIRECTIONS.
2. DO NOT put hands, feet, or clothing into any openings when changing positions on recliner. Attendant MUST confirm that users arms, legs, hands and feet are clear while changing recliner positions or **SERIOUS INJURY MAY OCCUR.**
3. Remove or move chair accessories out of the way of patients legs (ie. over-lap table & pivot table) when reclining/ changing position of patient.
4. LOCK casters at all times when chair is stationary. UNLOCK casters when moving/transporting chair.
5. STAY CLEAR of the recliner mechanisms when operating chair.
6. DO NOT use recliner for transporting in or with ANY type of vehicle or trailer. Winco recliners have not been tested or approved for use by an occupant in any type of vehicle or trailer.
7. NEVER use the chair arms or backrest, or tables as a seat; **SERIOUS INJURY OR DAMAGE MAY OCCUR.**
8. Periodically check the tightness of all nuts, bolts and screws.
9. Immediately REMOVE FROM SERVICE any recliner with broken recline mechanisms, torn upholstery, and/or other mechanical or visible damage.
10. USE ONLY WINCO AUTHORIZED REPLACEMENT PARTS.
11. NEVER EXCEED the recommended weight capacity.
12. This chair is NOT intended nor suitable for patient transport.

This section intentionally left blank

# ASSEMBLY INSTRUCTIONS

## PREPARATION:

1. Carefully examine your product for any damage. Inspect all components.  
IF DAMAGE IS EVIDENT, REFUSE SHIPMENT, & CONTACT FREIGHT CARRIER OR WINCO IMMEDIATELY.
2. Remove all packaging material that was secured for shipping.
3. Carefully remove the product from the carton.
4. Save all boxes and packaging material until after you have assembled your product and have verified that all components are functioning properly.

## REAR BRAKE ASSEMBLY INSTRUCTIONS:

This chair is shipped with the central-locking casters in the LOCKED position.

### To assemble the REAR central-lock lever:

1. Loosen thumb screw and slide the lever (A) onto the "HEX" portion of the bar.
2. Tighten thumb screw (B).
3. Lift UP on the lever to UNLOCK the central-locking casters.

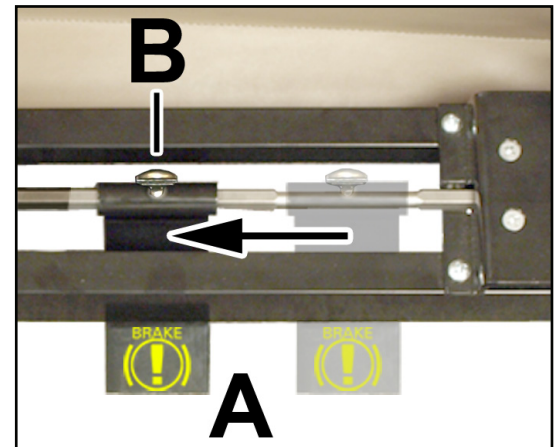

## BACK ASSEMBLY INSTRUCTIONS:

1. Lock casters by pushing down the central-lock lever located at the rear of chair. (See Lock/Unlock Casters pg.8)

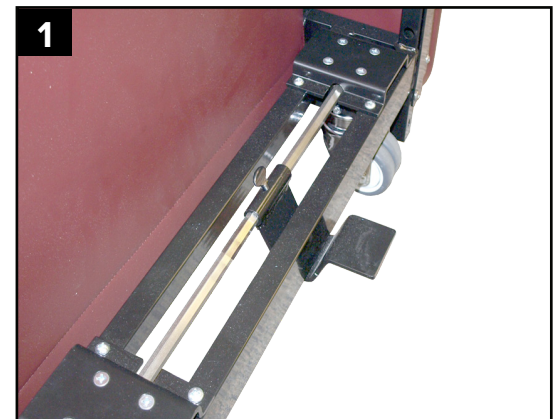

### IMPORTANT:

- Keep objects and persons clear of the chair before performing step 2.
2. Pull one of the recline levers (A), located on either side of the chair, until fully extended to bring the recline mechanism (B) into its upright position.  
**NOTE:** Legrest is spring loaded and will be rapidly released into the recline position when recline lever is pulled.
  3. Release the recline lever and push legrest in, to its stored position.

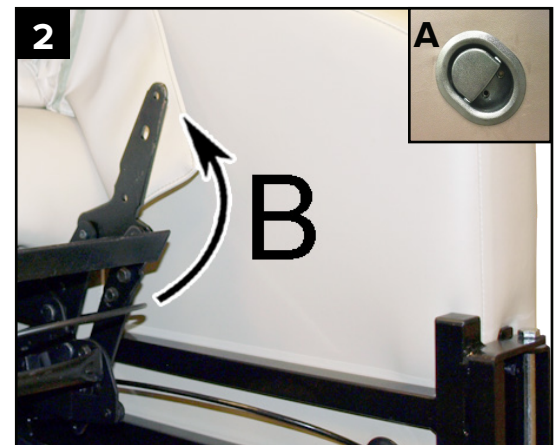

# ASSEMBLY INSTRUCTIONS

## BACK ASSEMBLY INSTRUCTIONS:

4. Hold the rear apron up, exposing the mounting brackets (A). Lift the upholstered back by its sides while aligning the mounting brackets with the recline mechanism (B).

**WARNING:**

- Keep hands clear of connection points or injury may occur

**IMPORTANT:**

- We recommend two people be used for step 4
- Be careful not to tear or puncture vinyl.

5. Slide the back onto the recline mechanism until the middle hole of the mounting bracket (A) is aligned with the middle hole of the recline mechanism (B).

6. Install knobs (A) (tethered to back) and tighten to a secure fit.

7. Ensure that the rear apron rests OVER the rear brace of chair.

**IMPORTANT:**

- Test to ensure the back has been properly installed by pulling up on the back. The back should remain securely in place.

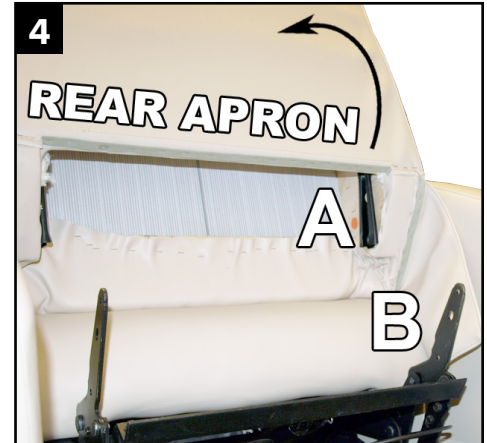

# ATTENDANT OPERATING INSTRUCTIONS

## CASTER OPERATION: Lock/Unlock

This chair features two types of casters, rigid and central-locking.

The front two casters are rigid casters. They are NOT designed to swivel in order to facilitate stable straight steering.

The rear two casters are central-locking casters. They are designed to swivel 360°. When central-lock is engaged, caster wheels will NOT roll and caster will NOT swivel.

### From the REAR of chair

1. TO LOCK REAR CASTERS: Press down on central-lock lever (A). Lever will lock into position.
2. TO UNLOCK REAR CASTERS: Lift up with foot on central-lock lever (A). Lever will return to the unlocked position.

#### **WARNING:**

- Ensure central locking brake is engaged at all times, particularly BEFORE seating an occupant in chair, and when occupant is exiting the chair.
- Ensure casters are UNLOCKED BEFORE moving or transporting chair.
- Never operate brakes without proper footwear. "Closed toe" shoes are recommended for operation of brake mechanism.

### From the FRONT of chair (OPTIONAL FEATURE)

3. TO LOCK REAR CASTERS: Push in on the side of the central-lock lever labeled "UNLOCKED" (3A). Lever will lock into position & "LOCKED" will be visible (4A).
4. TO UNLOCK REAR CASTERS: Push in on the side of the central-lock lever labeled "LOCKED" (4A). Lever will lock into position & "UNLOCKED" will be visible (3A).

#### **IMPORTANT:**

- Push "UNLOCKED" to LOCK
- Push "LOCKED" to UNLOCK
- The visible label indicates the current state of the chair casters.

#### **WARNING:**

- Ensure central locking brake is engaged at all times, particularly BEFORE seating an occupant in chair, and when occupant is exiting the chair.
- Never operate brakes without proper footwear. "Closed toe" shoes are recommended for operation of brake mechanism.

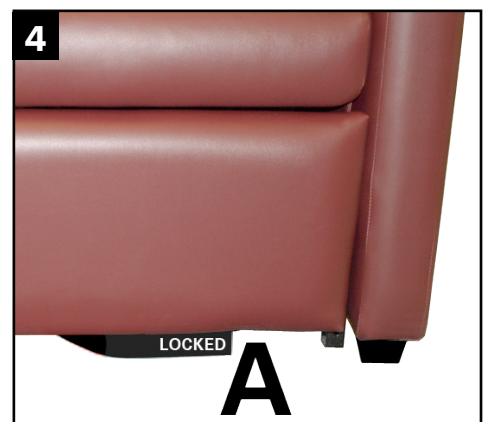
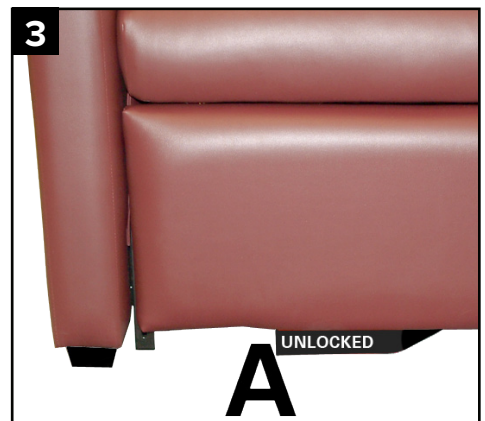
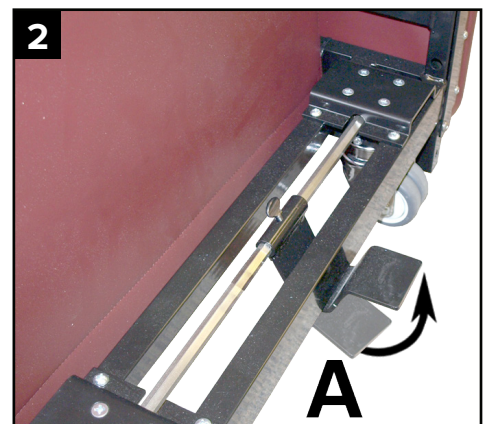
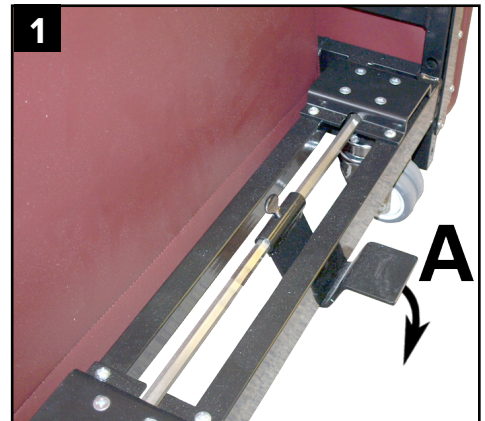



# ATTENDANT OPERATING INSTRUCTIONS

## RECLINE CHAIR FROM ATTENDANT POSITION:

Attendant should be positioned on the RIGHT or LEFT side of chair

1. While occupant is seated in the chair, use one hand to operate the recline lever, located on either side of chair, to activate the legrest into its raised position.

**NOTE:** Activate the legrest by pulling the recline lever (A) 1/2 way out. To recline the back, fully extend the recline lever (A).

2. To operate the infinite back positioning, after occupant's feet have been raised, use one hand to operate the recline lever (A) and the other hand to push on the upholstered back (B) until desired position or maximum recline has been reached.

Release recline lever (A) to maintain position.

**IMPORTANT:**

- Do NOT force the back of chair up or down without fully extending either of the two recline levers, this can damage the chair.

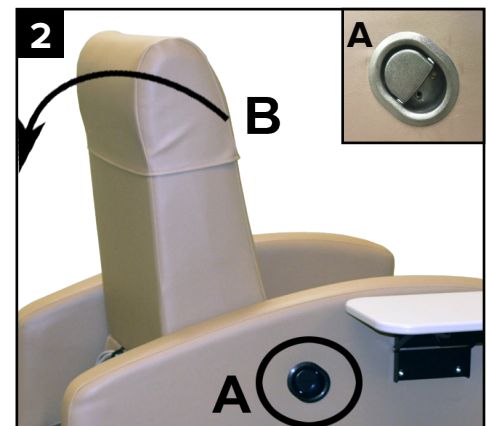
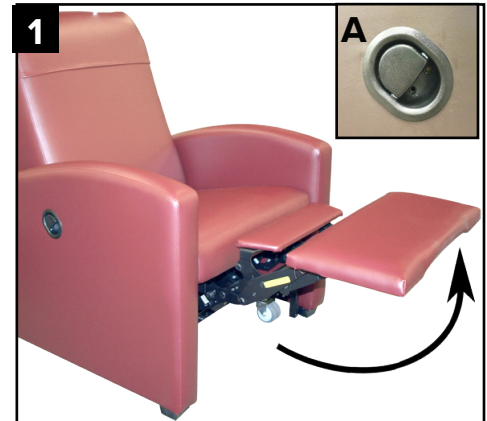

## RETURN CHAIR UPRIGHT FROM ATTENDANT POSITION:

Attendant should be positioned on the RIGHT or LEFT side of chair

1. While occupant is reclined in the chair, attendant should use one hand to operate the recline lever (A), located on either side of chair, while using the other hand to pull up on back (B).

Release the recline lever (A) once the back has fully returned to the upright position.

**NOTE:** To return the back to the upright position, fully extend the recline lever (A). Once the cack is returned to the upright position, release the handle and push the legrest closed.

2. Attendant should use one hand to push down on the legrest (A) until it locks into its stored position.

**NOTE:** The recline lever does NOT have to be used to return legrest to its stored position.

**WARNING:**

- Attendant should NOT use foot to return the legrest to it's stored position. Damage to mechanism and upholstery may occur.

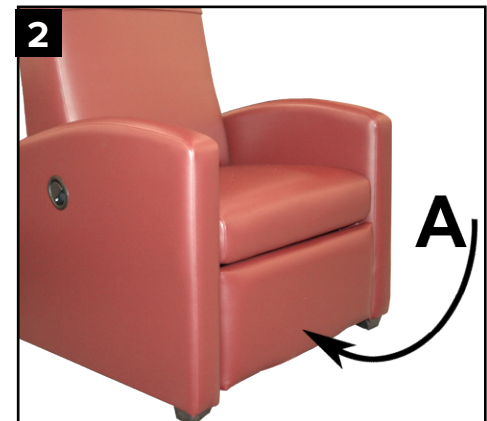
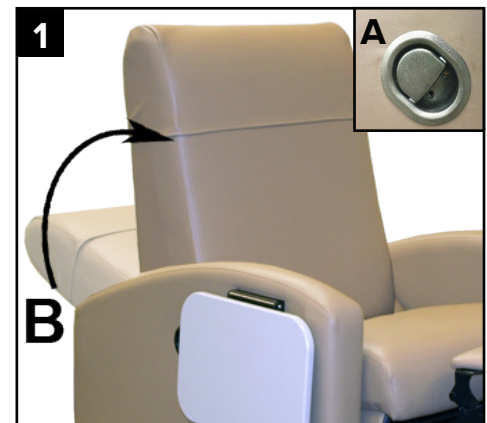

# ATTENDANT OPERATING INSTRUCTIONS

## SEAT REMOVAL AND REPLACEMENT:

### TO REMOVE THE SEAT:

1. Fully recline the chair back. (See previous page for instruction.)
2. Pull up on the front of the seat until it releases (A), then pull seat out away from the front of the chair (B).

### WARNING:

- Seat is tethered to chair frame. Do not forcefully pull on seat
- Chairs equipped with heat and massage:
- DO NOT attempt to unplug wires.
  - UNPLUG power cord from power source BEFORE seat removal, cleaning, or servicing of chair.
  - ENSURE all wiring for seat is clear of all moving parts of the mechanism before, during, and after re-installation of seat.

### TO INSTALL THE SEAT:

3. With the chair back fully reclined, slide the upholstered seat along mechanism until it stops (A), then press down on the front of the seat until it locks into position (B).

**IMPORTANT:** Ensure the side aprons of the seat are positioned outside of mechanism and do NOT interfere with seat installation.

4. Verify the seat has been correctly installed by carefully pulling up on the front and back of the seat. Seat should be secure and not move.

### WARNING:

- Attendant should NOT attempt to seat an occupant after seat has been re-installed without first verifying the seat has been installed correctly or serious injury may occur.

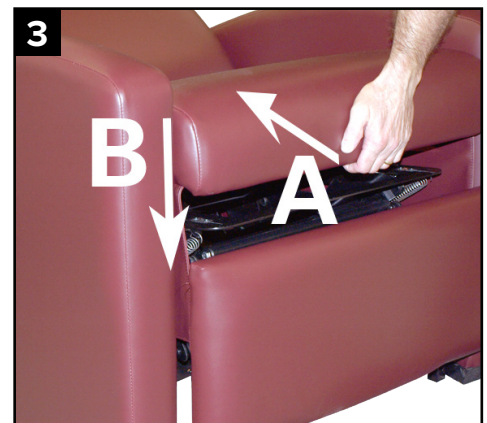
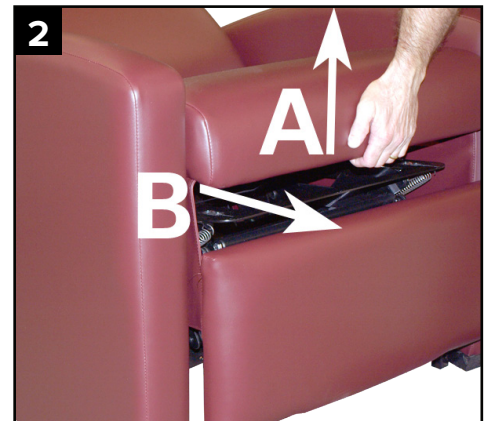

This section intentionally left blank

# ATTENDANT OPERATING INSTRUCTIONS

## SIDE-TABLE OPERATION: (OPTIONAL FEATURE)

1. TO RAISE TABLE: Grasp center of table and gently lift into place. Side-table will lock into place with an audible "click" once fully extended.

### WARNING:

- DO NOT lean or sit on side tables.
- DO NOT use table for support or assistance when exiting or entering the chair.
- Keep hands and objects clear of the moving parts of the table mechanism.

### IMPORTANT:

- Side-tables have been rated for a MAXIMUM weight capacity of 20 lbs. (9.0 kg)

2. TO STORE: Lift up on the lever located under the side-table and lower to its stored position.

### WARNING:

- Keep hands and objects clear of the moving parts of the table mechanism.

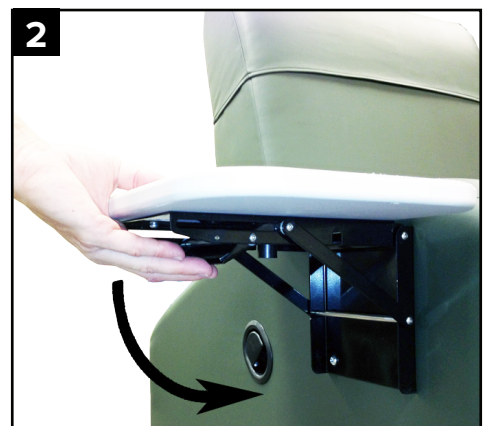
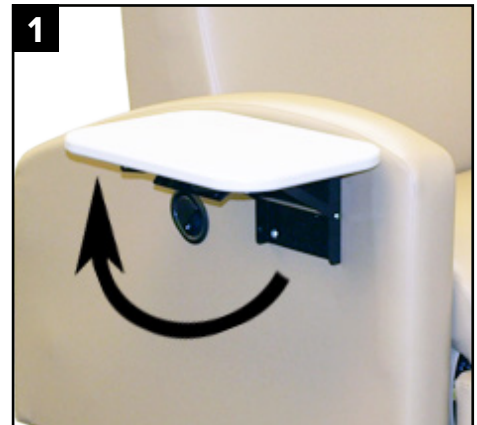

## PIVOT-TABLE OPERATION: (OPTIONAL FEATURE)

### TO POSITION THE TABLE:

1. Loosen the adjustment knob (A) and swing away or place in the "lap" position.
2. Tighten adjustment knob (A) to secure position.

### WARNING:

- DO NOT lean or sit on pivot-tables.
- DO NOT use table for support or assistance when exiting or entering the chair.

### IMPORTANT:

- Pivot-tables have been rated for a MAXIMUM weight capacity of 20 lbs. (9.0 kg)

### TO REMOVE THE TABLE:

3. Loosen the adjustment knob (A) 2 full turns and lift up on pivot-table.

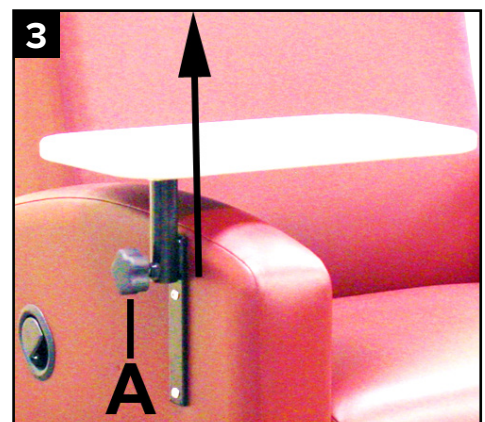
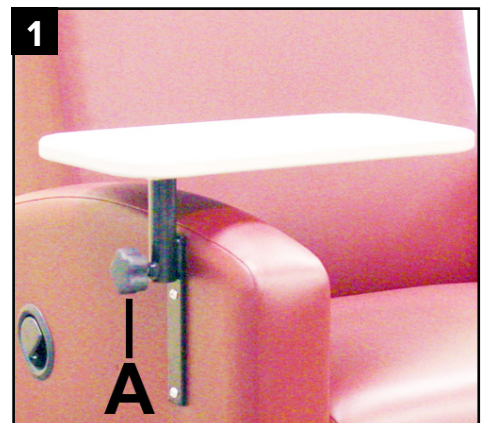

# OCCUPANT OPERATING INSTRUCTIONS

## RECLINE WHILE IN THE SEATED POSITION:

1. While seated in the chair, pull back on either of the recline levers (A), located on either side of chair, to activate the legrest into the recline position.

**NOTE:** Activate the legrest by pulling the recline lever (A) 1/2 way out. To recline the back, fully extend the recline lever (A).

2. To operate the infinite back positioning, pull back on the recline lever and adjust the upholstered back angle by pushing back with your body until desired angle has been reached.

Release recline lever (A) when you have achieved the desired angle to lock the back into position.

**WARNING:**

- DO NOT push or pull legrest to maneuver chair.
- DO NOT stand or sit on the legrest.
- DO NOT place hands, legs, or feet under seat, mid-ottoman, or legrest.
- Stay clear of recline mechanism when operating chair.

## RETURN TO THE SEATED POSITION:

1. To return the back to the full upright position pull back on either of the recline levers while sitting upright in the chair.

Release the recline lever once the back has fully returned to the upright position.

**NOTE:** To return the back to the upright position, fully extend the recline lever (A). Once the back is returned to the upright position, release the handle and push the legrest closed.

2. Press down on the legrest with legs/feet until it locks into place.

**NOTE:** The recline lever does NOT have to be used to return legrest to its stored position.

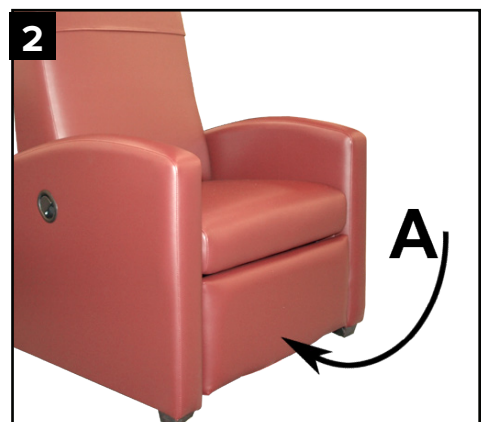
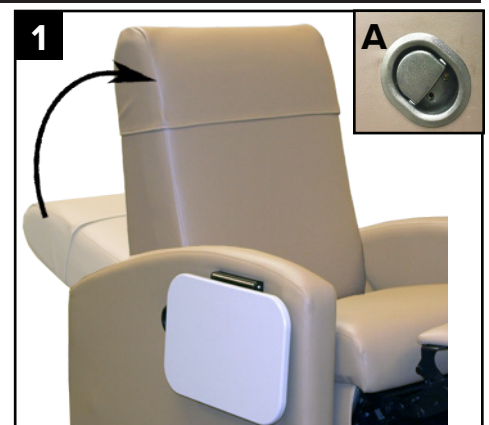
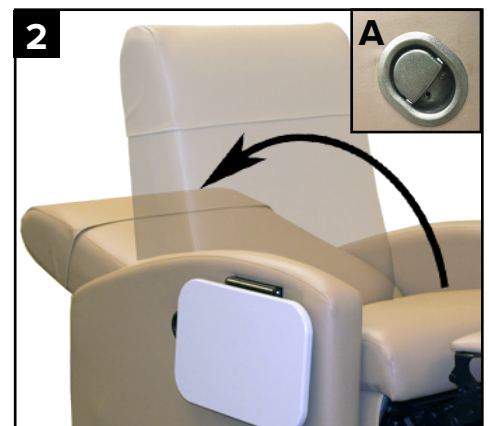
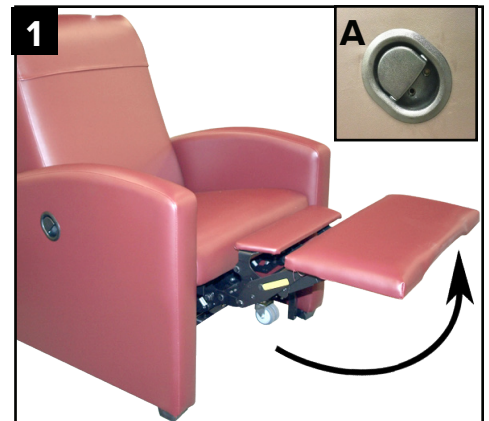

# OCCUPANT OPERATING INSTRUCTIONS

## OPTIONAL HEAT & MASSAGE OPERATION:

Control is located on the inside of right arm of chair. (Right is determined - as if sitting in the chair)



**Heating:** (Heating elements are located in the seat & back of chair)

Push HEAT button - See indicator light on switch

**3 Lights** = High Heat / Bright Light

**2 Lights** = Medium Heat / Med Light

**1 Lights** = Low Heat / Dim Light

**No Light** = HEAT OFF

Allow 5-8 minutes for back and seat to warm to desired setting.

Heat will automatically shut off after approximately 60 minutes. (Timer resets each time switch is pressed)

**Massage option:** (The massage option uses 4 separate motors located in the backrest of the chair. Two in the lower backrest, and two in the middle (upper) backrest.)

Push MASSAGE button

**1X** = Lower Back / Low Intensity

**2X** = Lower Back / High Intensity

**3X** = Upper & Lower Back / Low Intensity

**4X** = Upper & Lower Back / High Intensity

**5X** = Alternating Upper & Lower Back

**6X** = MASSAGE OFF

Massage will automatically shut off after approximately 15 minutes. (Timer resets each time switch is pressed)

### TROUBLESHOOTING:

- With system disconnected from power source, use a DAMP CLOTH ONLY to clean switch, wiring or power pack (located under seat frame).
- If there is no heat or massage or flashing light on the switch - check power cord connections to wall outlet AND connection of power cord to power pack unit under chair.
- If switch displays a flashing light; Disconnect from wall, check all accessible wire connectors under chair for possible loose connections, then re-plug into wall and test again.
- If system still does not work contact Winco customer service: 1-800-237-3377.

### CORD STORAGE:

(Models with Heat-HT or Heat & Massage-HM)

To prevent tripping on cord, damage to cord, or damage to recliner, the power cord should be coiled and stored in the "Hook & Loop" fastener provided BEFORE moving chair or whenever heat & massage is not in use.



# GENERAL MAINTENANCE

## GAS SPRING RELEASE ADJUSTMENT:

If recline levers fail to operate properly, adjust the gas spring using the instructions below.

1. Recline back of chair.  
(See pg. 9 "Recline Chair From Attendant Position")
2. Return legrest to stored position.
3. Remove the seat (A) and position as shown (B).  
(See pg. 10 "Seat Removal")

### WARNING:

- Seat is tethered to chair frame. Do not forcefully pull on seat.

### Chairs equipped with heat and massage:

- UNPLUG power cord from power source BEFORE removing seat, cleaning, cleaning or servicing chair.
  - Chairs equipped with heat and massage - DO NOT attempt to unplug wires.
  - ENSURE all wiring for seat is clear of all moving parts of the mechanism before, during, and after re-installation of seat.
4. Locate the gas spring and loosen the nut on the gas spring using an 11/16" wrench.

5. Remove the opposite end of gas spring by removing the cotter & clevis pin.

Proceed to step 6 or 7 depending on the necessary adjustment.

### IMPORTANT:

- DO NOT allow button on end of cylinder to depress while performing this task.

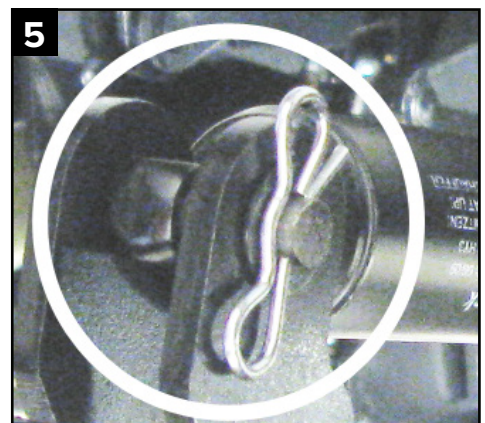
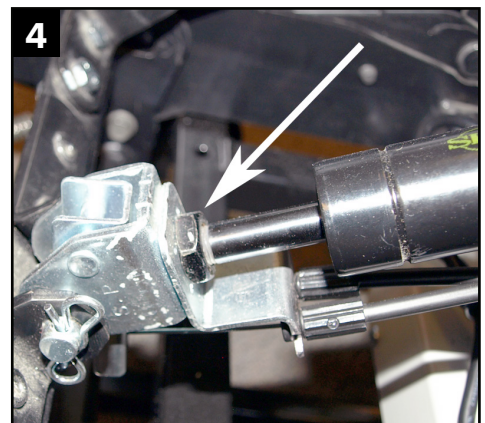
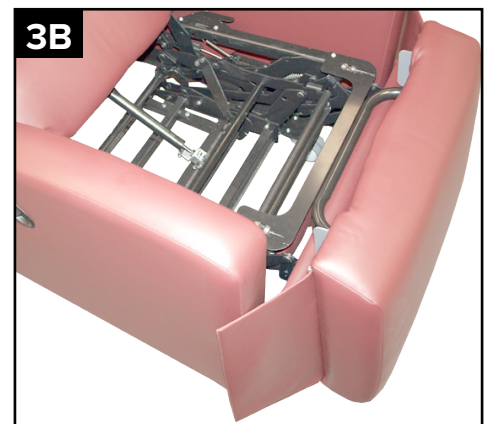
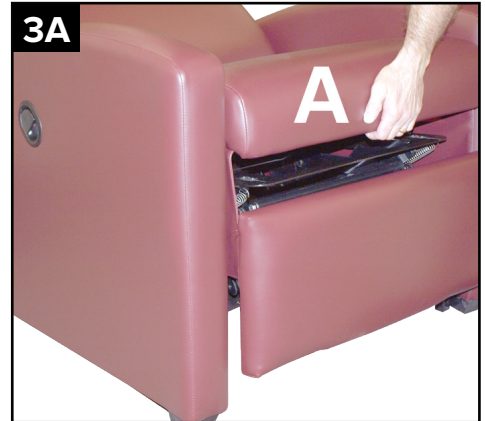

# GENERAL MAINTENANCE

## GAS SPRING RELEASE ADJUSTMENT: (continued)

### Chair will not recline:

6. If chair will NOT recline when left or right recline levers are pulled, rotate the gas spring clockwise (A) half (1/2) of a revolution (or 180°).

### Chair reclines without the use of recline levers:

7. If the chair reclines without the use of recline levers, rotate the gas spring counter-clockwise (B) half (1/2) of a revolution (or 180°).
8. After adjustment; Replace Clevis Pin and Bow-Tie Cotter Pin.
9. Pull the recline lever (A) and push back on the chair back (B) to check for proper adjustment. Repeat above steps as needed until correct release action is achieved. Then TIGHTEN HEX NUT (that you loosened in step 5).

### **IMPORTANT:**

- Make sure all bow tie cotter pins are securely inserted in all clevis pins.

### **WARNING:**

- Failure to securely insert the bow tie cotter pins into the clevis pin could cause the clevis pins to fall out and result in injury, or damage to the chair.

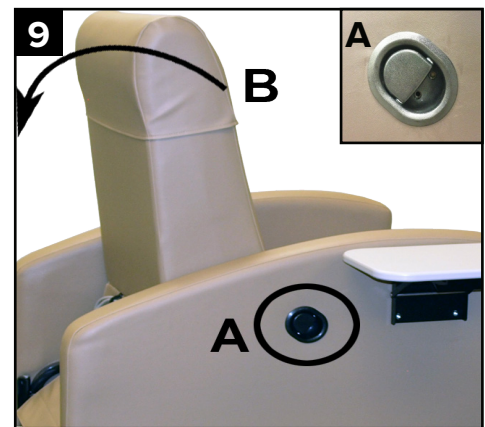
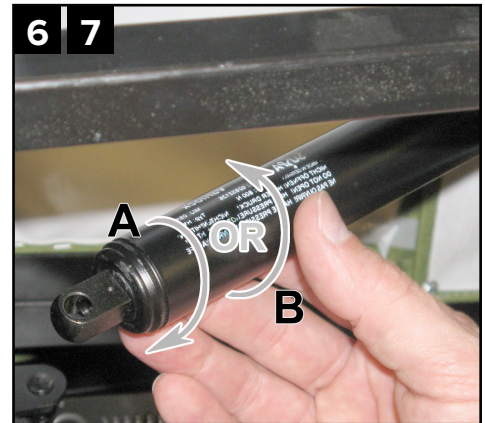

## GENERAL CARE & CLEANING:

- REGULARLY lubricate pivot points on the recline mechanism with a lubricant approved by your facility. Periodically position the chair back into full recline position to keep the gas cylinder lubricated.
- Periodically inspect tightness of all screws, bolts, and nuts.
- Winco furnishings are built to provide durable reliable service when properly cared for. In general all of our products should be 1) Cleaned 2) Rinsed 3) Allowed to air dry. It is important to note that disinfecting a product is not the same as cleaning the product. Disinfectants alone will not provide adequate cleaning, they do not have grease or oil cutting properties to remove grime or hair and skin oils. Over time, the appearance and feel and performance of your upholstery may diminish if not cleaned properly

### **CLEANING:**

Remove grime, hair and body oils; Your furnishings should be cleaned with mild soap & water solution and a damp cloth on a regular basis (especially where skin & hair make contact with upholstery). Avoid harsh detergents that could damage the upholstery or finish of your recliner. If the furnishing is disinfected with bleach, it MUST be wiped off using only clean water on a damp cloth and then be allowed to air dry. Failure to rinse upholstery with clean water can result in a build-up of residues over time that can dry out the upholstery and cause changes to the look and feel of the upholstery and eventually can lead to cracking.

### **WARNING:**

- When seat is removed, use caution cleaning in and around mechanisms. Keep hands clear of pinch points & metal edges or injury may occur. Disconnect power (Chairs w/ HM or HT option) when cleaning chair.

# AUGUSTINE RECLINER SPECIFICATIONS



## Specifications

Seat Height .....	..19.75"	Back Height Above Seat.....	28.5"
Seat Width (arm to arm).....	..25.75"	Seat Depth.....	20.75"
Overall Height .....	..45.75"	Weight .....	181lbs.
Overall Width.....	34.5"	Overall Length.....	40"
(With OPTIONAL Trays Up).....	45.5"	Overall Length Reclined.....	76"

**Maximum Weight Capacity....500 lbs.**



# AUGUSTINE RECLINER OPTIONS

## Heat & Massage

HM .....Heat & Massage  
 HT .....Heat ONLY  
 FACTORY INSTALLED ONLY



## Side-Table

Available on LEFT, RIGHT, or BOTH sides  
 (Also available with Wood Finish)



## Pivot-Table

Available on LEFT, RIGHT, or BOTH sides  
 (Marine Board Only)



## IV Pole & Attachment

IV.....IV Pole & Attachment  
 (Left or Right Side)



## Accessory Holder

AH.... Accessory Holder  
 (Left, Right, or Both Sides)



## Central Front Brake

BE.....Central Front Brake

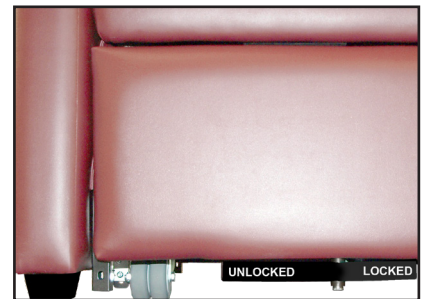

## Armrest Covers

AIRX.....ARMREST COVER RIGHT  
 AILX.....ARMREST COVER LEFT



## Urethane Arm

UB.....Urethane Arm



## Headrest Cover & Pillow Set

NP.....Headrest Cover & Pillow Set



# ARMREST COVER OPTION INSTRUCTIONS

## Installing Armrest Covers with Side Tables:

1. Raise the side table by grasping the center of the table and gently lift into place.
2. Locate large square opening in cover and position over the side table. Stretch the opening over the side table and slide over side table.
3. Fit the front portion of the Armrest cover over the front of the arm. Pull down tight for best fit.
4. Fit the rear portion of the Armrest cover over the rear of the arm.
5. Smooth wrinkles.
6. Make sure openings align with release handle.

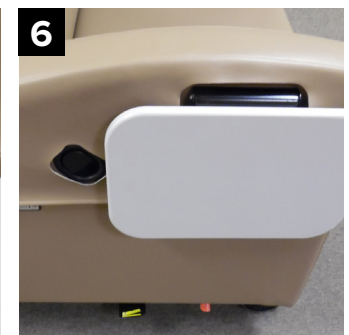
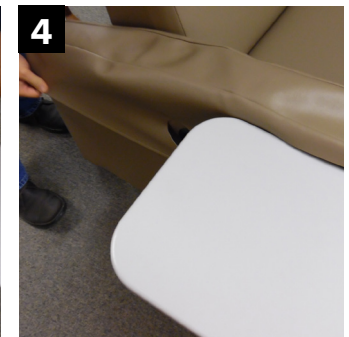
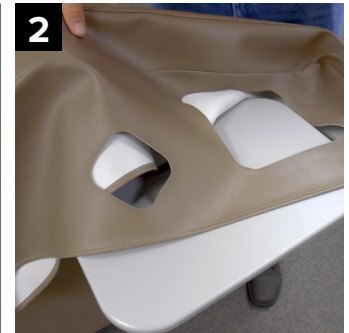
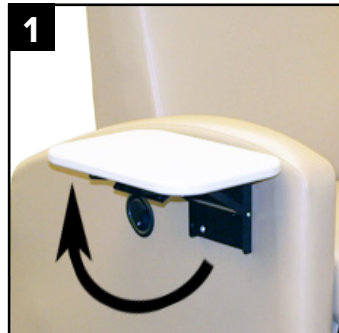

# ARMREST COVER OPTION INSTRUCTIONS

## Installing Armrest Covers with Pivot Tables:

1. Loosen pivot table knob.
2. Remove pivot table by pulling straight up on pivot table.
3. Find pivot table opening in armrest cover located in the upper front portion of the armrest cover.
4. Place pivot table opening over pivot table bracket and fit armrest cover over the front portion of the arm.
5. Fit the rear portion of the Armrest cover over the rear of the arm.
6. Gently insert pivot table into bracket.
7. Tighten knob.

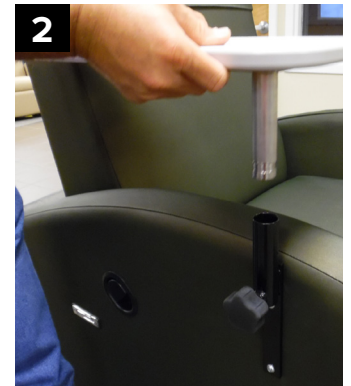

# ARMREST COVER OPTION INSTRUCTIONS

## Installing Armrest Covers with IV Poles:

1. Using a Phillips screw driver, remove the top screw mounting the IV bracket to the arm and loosen the bottom screw enough to allow the bracket to move. (Be careful not to allow the bracket to damage the vinyl)
2. Fit the armrest cover over the rear of the arm and pull tight.
3. Use the Phillips screw driver to punch a hole in the armrest cover in line with the top mounting hole for the IV bracket.
4. Reattach the bracket using the screw that was removed in step 1. Tighten both screws.



This section intentionally left blank

**OTHER PRODUCTS SUPPLIED BY WINCO**

# **VERÒ CARE CLINER COLLECTION™**



**PLEASE DO NOT DISCARD THIS MANUAL! KEEP FOR FUTURE REFERENCE AND TRAINING**

# OTHER PRODUCTS SUPPLIED BY WINCO



Clinical Recliners



Exam Tables



Convalescent (LTC) Recliners



Privacy Screens



Phlebotomy Chairs



Specialty Chair Stretcher-Chair



Stools



Oncology and Dialysis Chairs



## WINCO MFG., LLC LIMITED WARRANTY

### TERMS

*Winco Mfg., LLC., warrants this product to be free of manufacturer's defects in material and workmanship, provided that the product is used according to normal operating conditions and proper maintenance intended by manufacturer. This warranty is available only to the original retail purchaser, is non-transferable and commences on the date of retail sale; proof of purchase required.*

- **Limited One Year Complete Product Warranty:** Winco Mfg., LLC warrants the complete product for one (1) year. At Winco Mfg., LLC's sole discretion, it may repair or replace any components freight free that are found to be defective during the first year after shipment from the Winco facilities. *Winco Mfg., LLC, shall not be liable for any labor, or any other costs incurred as a result of or in conjunction with a warranty claim.*
- **Limited Three-Year Warranty:** Winco Mfg., LLC warrants the recliner mechanisms, casters, electrical components, vinyl [from cracking or delaminating], and pressurized gas springs, for a period of three (3) years. At Winco Mfg., LLC's sole discretion, it may repair or replace components found to be defective. *Winco Mfg., LLC, shall not be liable for any labor, shipping or any other costs incurred as a result of or in conjunction with a warranty claim.*
- **Limited Lifetime Chair Frame Warranty:** Winco Mfg., LLC warrants the steel chair frame, when new, for the lifetime of the original purchaser. This limited warranty does not apply to paint/finish or any components attached to the frame such as; upholstery, foam, casters, mechanisms or related parts that are covered under above warranties. *Winco Mfg., LLC shall not be liable for any labor, shipping or any other costs incurred as a result of or in conjunction with a warranty claim.*

The purchaser's exclusive remedy under this warranty shall be limited to such repair or replacement of defective components at Winco Mfg., LLC sole discretion. For warranty service, contact the dealer that the product was originally purchased from or Winco Mfg., LLC directly.

### EXCLUSIONS

There are no other warranties, conditions, representations or guarantees, express or implied, made or intended by Winco Mfg., LLC and all other warranties, conditions, representations or guarantees including any warranties, conditions, representations or guarantees under any Sale of Good Act or Like legislation or statute is hereby expressly excluded. Any and all other implied warranties shall not extend beyond the duration of the express warranty. Liability for incidental or consequential damages is excluded to the extent permitted by law. Some states do not allow exclusions or limitations so the above limitations or exclusions may not apply to you. This warranty gives you specific legal rights. In addition, you may also have other rights, which vary from state to state.

### GENERAL PROVISIONS

No warranty herein contained or set out shall apply when damage or repair is caused by any of the following:

1. Damage in transit
2. Accident, alteration, abuse or misuse of product i.e., exceeding weight capacities, applying inordinate pressure to footrest/leg rest, use in Mental Health facilities or like institutions
3. Fire, water damage, theft, war, riot, hostility, acts of God

*Examples contained in this list are not to be construed as all-inclusive.*

5516 SW 1st Lane  
Ocala, FL 34474

**WEB** wincomfg.com  
**PHONE** 800 237 3377  
**FAX** 352 854 9544

ISO 13485: 2016





## CONTACT US

To arrange a demonstration or to speak with one of our associates, please feel free to contact us at:  
**800-237-3377 | [WincoMfg.com](http://WincoMfg.com) | 5516 SW 1st Lane, Ocala, FL 34474 | [Info@WincoMfg.com](mailto:Info@WincoMfg.com)**