

Instructions for Use

OA EASE

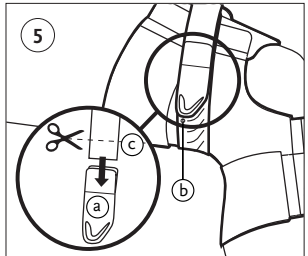

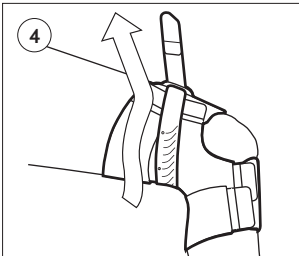
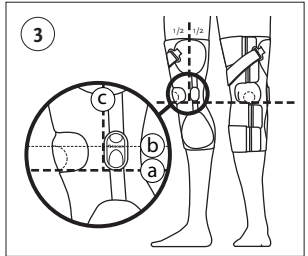
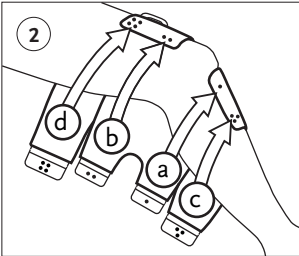
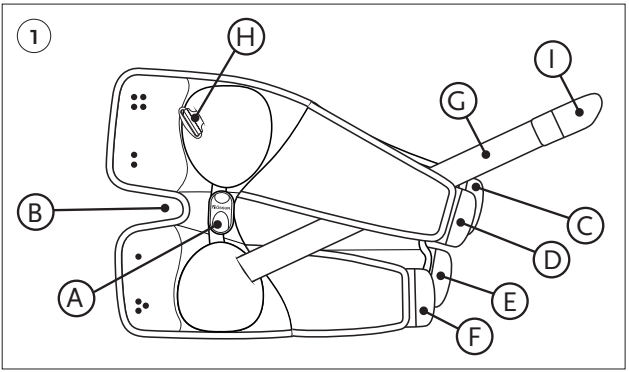

INTENDED USE

The device is intended for unicompartmental unloading of the knee
The device must be prescribed by a healthcare professional.

Indications for use

- Unicompartmental osteoarthritis of the knee.
- Other conditions that may benefit from unicompartmental unloading, such as degenerative meniscal tears.

No known contraindications.

Warnings and Cautions:

- Regular healthcare professional supervision is recommended for patients with peripheral vascular disease, neuropathy, and sensitive skin.
- Make sure the device fits properly to minimize the possibility of skin irritation. Increase usage time gradually as the skin adapts to the device. If redness appears, temporarily decrease the usage time until it has subsided.
- Care should be taken not to overtighten the device.
- Make sure the device fits properly to achieve effective pain relief.
- The use of the device may increase the risk of deep vein thrombosis and pulmonary embolism.

GENERAL SAFETY INSTRUCTIONS

The healthcare professional should inform the patient about everything in this document that is required for safe use of this device.

Any serious incident in relation to the device must be reported to the manufacturer and relevant authorities.

The patient should stop using the device and contact a healthcare professional:

- If there is a change or loss in device functionality, or if the device shows signs of damage or wear hindering its normal functions.
- If any pain, skin irritation, excessive pressure, or unusual reaction occurs with the use of the device.

The device is for single patient – multiple use.

FITTING INSTRUCTIONS

While carrying out the following instructions, please refer to the overview figure for locating components mentioned in the text (**Fig. 1**).

Device Application

1. Ask the patient to sit down on a chair and partially bend the knee with the foot flat on the floor. Position the fully opened device on the leg so that the Hinge (A) is on the affected side of the knee and the Kneecap Opening (B) is positioned around the kneecap (**Fig. 2**). Ensure proper alignment of the device on the leg (**Fig. 3**).
 - Height positioning: Lower edge of the Kneecap Opening should be below the kneecap (3a) and align Össur logo on the Hinge with upper edge of the kneecap (3b).
 - Side positioning (3c): Front edge of the Hinge cap should be at midline of leg.

2. Attaching the Tabs (C, D, E, F).
 - While keeping the device in place with one hand, affix the Tabs in the order shown to the fastening locations on the device (**Fig. 2: a, b, c, d**). The dot symbols on each Tab and fastening location indicate the correct sequence and locations for attachment.
 - • Make sure all the Tabs are tight but comfortable. If necessary, adjust the Tabs again.
3. Attaching the DFS Strap (G).
 - Ask the patient to sit down on a chair and bend the knee with the foot flat on the floor. Move the DFS Strap behind the leg and thread it through the D-ring (H) (**Fig. 4**).
 - Detach the Alligator Clip (I) (**Fig. 5a**) and fasten it to the “5” position on the DFS Strap (5b).
 - While keeping the device in place with one hand, tighten the loose end of the DFS Strap down over the Alligator Clip. When sufficiently tight and sitting firmly against the leg, fold the DFS Strap into the Alligator Clip.
4. Have the patient stand up and take a few steps to verify correct positioning of the device (**Fig. 3**) and tightness of the DFS Strap and Tabs.
 - Determine optimal DFS Strap tension based on patient's pain relief feedback.
 - If patient requires more or less tension with the Alligator Clip at the “5” position, adjust the length of the DFS Strap accordingly.
 - Aim for final DFS Strap placement at the “5” position since this will give patient the ability to adjust dosing during daily life activities.
5. When final fit has been confirmed, trim the DFS Strap to the appropriate length (5c).

Device Removal

1. Ask patient to sit down with the leg extended.
2. Remove the DFS Strap from the D-ring.
3. Unfasten the Tabs from the fastening locations on the device.

Accessories and Replacement Parts

Please refer to the Össur catalog for a list of available replacement parts or accessories.

USAGE

Cleaning and care

Note: Secure the hook and loop fasteners before washing to avoid damaging the textiles.

Washing Instructions

- Insert the entire device into a washbag, without removing soft goods.
- Machine-wash with a mild detergent at cold temperature (30°C).
- Air dry.

Note: Do not tumble dry, iron, bleach, or wash with fabric softener.

Note: Avoid contact with salt water or chlorinated water. In case of contact, rinse with fresh water and air dry.

DISPOSAL

The device and packaging must be disposed of in accordance with respective local or national environmental regulations.

LIABILITY

Össur does not assume liability for the following:

- Device not maintained as instructed by the instructions for use.
- Device assembled with components from other manufacturers.
- Device used outside of recommended use condition, application, or environment.