

MVP 502 series (KM-5000.2)

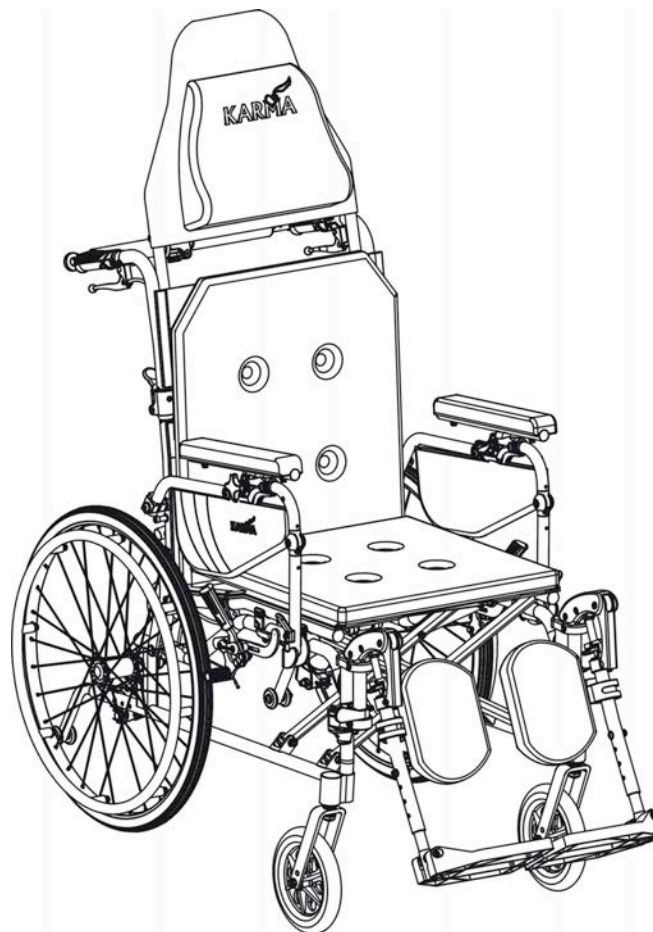

ISO 9001



Lead the way, all the way!

GENERAL WARNING

- DO maintain your chair, particularly, check the tire pressure since this affects the efficiency of the brakes.
- DO make sure both brakes are applied before getting in or out of the chair.
- DO make sure both brakes are applied when the chair is not being pushed or used.
- DO pay special attention when climbing curbs or turning on slopes.
- DO avoid steep or uneven surfaces that may cause the chair to tip over.
- DO avoid soft surfaces as the casters may become bogged down.
- DO travel smoothly under all conditions.
- DO look ahead to anticipate hazards such as furniture, doors, and potholes, etc.
- DO make sure that both feet are safe on the footrests and that clothing is safely tucked out of the way so that it cannot get caught in the wheels.
- DO take care when traveling up or down or across inclines.
- DO keep both hands on the push handles to control the chair, if you are the attendant.
- DO pay attention to keep the chair balanced.
- DO check the frame and components regularly and refer to this user guide during and after the warranty period.
- DO tie-up the upholstery or replace which with a new one when it becomes loose.
- DO lubricate bearings regularly.
- DO equip with anti-tippers to avoid falling backwards.
- DO equip with a seat belt designed for disabled people.
- DO equip with "ankle supports" for disabled people.
- DO clean both hands after oiling the wheelchair.
- DO tighten the screws of headrest tubes.
- DO NOT overload the chair in any circumstance.
- DO NOT hang anything heavy on the back of the chair that could cause the chair to become unstable, particularly when negotiating inclines.
- DO NOT allow more than one user at a time.
- DO NOT use with an unconscious patient.
- DO NOT use other transport to pull the wheelchair.
- DO NOT do "wheelies", as you may fall or tip over backwards and suffer a severe injury.
- DO NOT sit in the wheelchair within a moving vehicle unless it has been affixed the labels of hook mark.
- DO NOT go too fast or turn too quickly.
- DO NOT stand on the footplates when getting in or out of the chair.
- DO NOT go down steps forward, whether solo or with an attendant.
- DO NOT attempt to lift the wheelchair by any removable (detachable) parts. Lifting by means of any removable (detachable) parts of the wheelchair may result in injury to the user and/or assistant or damage to the wheelchair.
- DO NOT use the wheelchair when the back is folded. This alters the centre of gravity and may cause the wheelchair to tip backwards. The back should only be folded for storage or transport of the wheelchair.
- DO NOT hang anything on the back joint that could cause the backrest folding suddenly and may cause injury.

YOU AND YOUR KARMA SERVICE PROVIDER

- No tools are required for assembly. Your wheelchair should be assembled by your authorized Karma dealer. Your authorized Karma dealer is also your service provider. Unauthorized repairs, upgrades and add-ons will negate your warranty. Anything wheelchair related that requires tools should be done by your authorized Karma service provider. Your Karma service provider has the necessary service/maintenance manual for your wheelchair.
- If you have any defective parts or lose any parts, please contact your dealer for repair and/or replacement. Please only use parts authorized by Karma. Use of parts that are not authorized by Karma will negate your warranty.
- Part numbers are listed on our bill of materials (explosion drawings), which we give to our authorized dealers and service providers. Customers should order parts through their dealer as well as all repairs and scheduled maintenance.
- Customers should go to their dealership for all service needs to guarantee their warranty is not nullified. Always go to an authorized service provider. Unauthorized repairs will nullify your warranty. Procedures other than those described in this manual must be performed by a qualified technician. They also have the service manual with a complete list of maintenance required to keep your Karma wheelchair in top performance. Check the warranty section of this manual to find out what Karma guarantees and what maintenance and parts you will have to pay for.
- Karma does not have an official list of service providers at this time. Please contact your dealer for service. If you cannot contact your dealer, please contact another authorized Karma dealer for service. If all else fails, contact Karma directly via our website or give us a call and we can refer you to your new service provider.

CE MARKING

This wheelchair complies with the requirements of the Medical Devices Directive 93/42/EEC.



CAUTION:

Before purchasing and using Karma wheelchairs, please consult qualified professionals so as to ensure that you choose suitable products and use them correctly as well. For safety reasons, if there is any risk due to the user's movement in the wheelchair or other environmental factors that might cause the wheelchair to tip or the person on the wheelchair to fall off, Karma recommends that you install anti-tippers, safety belt, or other additional safety accessories.



TABLE OF CONTENTS

1. PREFACE.....	1
2. SAFETY.....	2
3. INTENDED USE & PARTS.....	6
4. OPERATION.....	8
5. INSPECTION AND MAINTENANCE.....	19
6. OPTIONS AND ACCESSARIES	Error! Bookmark not defined.
7. TROUBLESHOOTING.....	24
8. SPECIFICATIONS.....	24
9. CLEANING & RECYCLING.....	25
10. WARRANTY.....	25

1. PREFACE

Please carefully read this owner's manual before using the wheelchair. Improper use of the wheelchair could result in harm or injury. Therefore, for safe and enjoyable use of the wheelchair, please read this owner's manual.

- This owner's manual includes operation instructions for the aspects of the wheelchair, unfolding/folding instructions, and instructions on how to deal with possible accidents.
- This owner's manual is for Karma wheelchair: MVP 502 series.
- The symbols used in this manual are given and explained below. Pay special attention to the parts marked with these symbols.

	WARNING:	Improper use could lead to serious injury or death.
	CAUTION:	Improper use could lead to serious injury and/or damage to your wheelchair.
	SUGGESTION:	Follow these instructions to keep the wheelchair in good condition.

- This manual includes the repair and maintenance chart as well as the warranty.
- If someone else uses the wheelchair, make sure that you give him or her this owner's manual for his or her reference.
- As designs change, some illustrations and pictures in this manual may not correspond to the wheelchair that you purchased. We reserve the right to make design modifications without further notice.

2. SAFETY

2.1 Doorways

The safest way to operate the chair is on level floors that are free of obstacles. Whenever possible use a ramp to enter or exit a facility. Keeping your hands on the push rims will allow you to maintain maximum balance. Do not try to force yourself over an obstruction by propulsion and never use the sides of a doorway to pull yourself through a passageway.

2.2 Leaning

Do not lean over the side of your wheelchair since such an action may cause you to lose balance and fall. (See Figure 2.1)

2.3 Navigating Inclines

Never turn on a hill due to the danger of tipping.

When assisting, go straight up a slope. If user needs to go down midway, walk backwards until user is on level ground. (See Figures 2.2 and 2.3)

Avoid stopping on an incline; it can potentially cause you to lose control of the chair.

Do not use the brakes to slow down or stop the wheelchair; this could cause it to seize up, causing you to lose control or fall out of the chair.

Whenever possible, utilize help from an assistant/attendant while navigating inclines.

2.4 Curbs

Whenever possible get help from an assistant/attendant (if you have assistance make sure that your chair is equipped with push handles).

Avoid hard impacts when descending a curb. A hard impact could adversely affect the chair.

Never try to scale or descend curbs that exceed a normal height. (30-50cm)

Always be careful when climbing curbs and never move up or down a curb in reverse without an assistant.

2.5 Stairs

Always use two or more assistants. Tilt the wheelchair to its point of equilibrium. One assistant (at the back) holds the wheelchair up against the first step, gripping the handles firmly to lift. The second assistant, holding firmly a fixed part of the front frame, lifts the wheelchair above the stairs and holds it while the first attendant place one foot on the following step and repeat the operation. (See below figure)

Never go down steps forwards.

Never use an escalator for transport, use an elevator.



2.6 Streets

Always use extreme caution when crossing streets. Reflective tape on the chair and/or your clothing will make you more visible to drivers.

Avoid potholes and rough terrain that might cause the casters to become stuck. (See Figure 2.4)

2.7 General

- Always make sure BOTH brakes are applied before getting in or out of the chair.
- Never stand on the footplates when getting in or out of the chair.
- Never carry more than one passenger. Karma wheelchairs are limited to one user.
- Use caution to assure your clothing doesn't get tangled with the wheels.

2.8 Transport

- Do not use other transportation to pull the wheelchair.
- Do not get transported on any vehicle while seated in your wheelchair. Karma doesn't approve of any tie-down systems. Please transfer into seating approved by the automotive (or other) industry and wear a safety belt.

2.9 Upholstery

- When cleaning the upholstery, use warm water and a mild soap.
- Upholstery cleaner/foam can also be used, but avoid other cleaning solvents.

2.10 Anti-tippers

Anti-tipper must be installed under all conditions, especially when the backrest is reclined. (See below figure)



2.11 Maximum User Weight Limit

Refer to "Max. User Weight" in section 8. SPECIFICATIONS. Loads exceeding maximum capacity can damage your wheelchair and cause malfunctions yielding a safety hazard. The warranty does not cover damage caused by improper operation of the wheelchair.

2.12 Avoid General Misuse

Please note that our "Owner's Manual" contains a number of cautions -- any vehicle can cause injury if misused -- use within our guidelines and with reasonable care and your safety will be increased. Your wheelchair will give years of safe use if used sensibly and carefully. Be aware that careless use endangers your own safety as well as that of others. ALWAYS follow the Highway Code when outdoors and the guidelines written in this manual.

Do not let children stand or play on the wheelchair. (See Figure 2.5)



Figure 2.1



Figure 2.2



Figure 2.3



Figure 2.4



Figure 2.5

2.13 Labeling

Please carefully read all the labeling on the wheelchair before driving it. Do not remove them. Protect them for future reference.



1

 KARMA Karma Medical Products (UK) Ltd. <small>28 Hewfield Road, Hagley, Stourbridge, West Midlands, DY9 0JR UK Tel: +44 (0)152 885097 Fax: +44 (0)152 886838</small>	
WARNING! USE ONLY ON STABLE SURFACES MAXIMUM USER WEIGHT 115kg (255lbs)	

2

Serial NO: MXXXXXXX

3

Model:	
Order No.:	
Delivery Date:	
Sewing No.: <input type="checkbox"/> 1 <input type="checkbox"/> 2 <input type="checkbox"/> 3 <input type="checkbox"/> 4 <input type="checkbox"/> 5 <input type="checkbox"/> 6	
Seat Width	Seat Depth
<input type="checkbox"/> 13	<input type="checkbox"/> 13
<input type="checkbox"/> 14	<input type="checkbox"/> 14
<input type="checkbox"/> 16	<input type="checkbox"/> 16
<input type="checkbox"/> 16	<input type="checkbox"/> 16
<input type="checkbox"/> 17 <input type="checkbox"/> 0	<input type="checkbox"/> 17 <input type="checkbox"/> 0
<input type="checkbox"/> 18 <input type="checkbox"/> 5	<input type="checkbox"/> 18 <input type="checkbox"/> 5
<input type="checkbox"/> 19	<input type="checkbox"/> 19
<input type="checkbox"/> 20	<input type="checkbox"/> 20
<input type="checkbox"/> 21	<input type="checkbox"/> 21
<input type="checkbox"/> 22	<input type="checkbox"/> _____
<input type="checkbox"/>	<input type="checkbox"/>
KARMA	Unit: inch 105-90099

3. INTENDED USE & PARTS

3.1 Intended Use

- The MVP 502 series can be either propelled by the user or by the attendant.
- These wheelchairs are suitable for users up to 253 lbs in weight. Hand brakes are provided for both rear wheels and are connected to a dual attendant brake located on the left push handle.
- It has pneumatic tires for traction and comfort. It also has an extremely durable aluminum alloy frame with tough accessories and does not suffer in dramatic extremes of temperature (neither user nor attendant need touch metal parts in normal use).
- This chair is designed for both indoor and outdoor use.
- The casters have PU tires for greater durability; pneumatic casters are available on request.
- Rear wheels are 22 inches in diameter and solid PU tires are available on request.
- When prescribing wheelchairs for use by full or partial amputees (above or below knee, single or double) or other conditions that affects the user's natural center of gravity, we suggest contacting your therapist or dealer as well as attaching anti-tippers.
- Backrest reclines smoothly from 93-160 degrees.
- Lightweight foldable design allows easy transport.
- The gas cylinders give attendant to recline user more easily

3.2 Parts Description MVP 502 F22

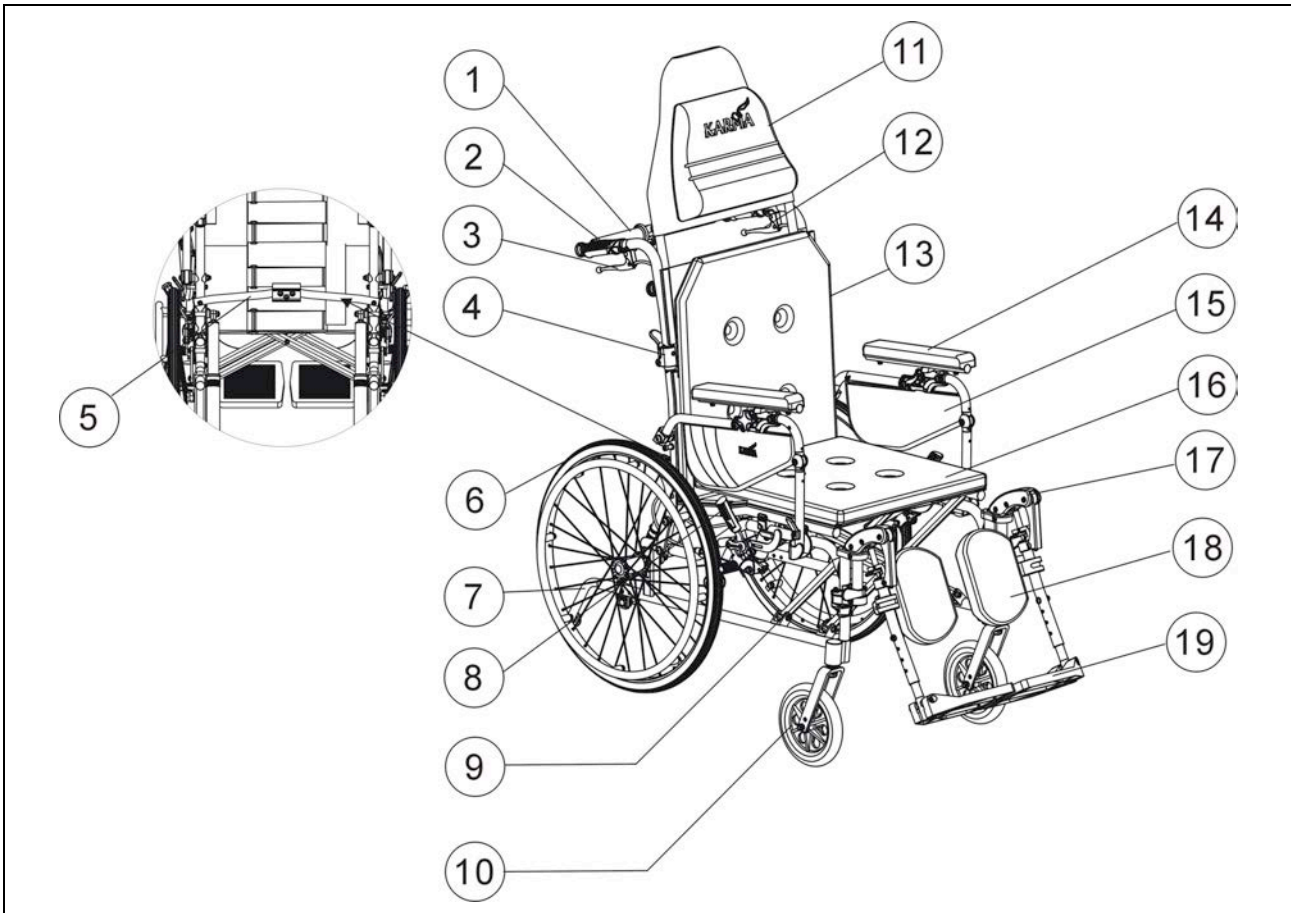

1. Rigidifying Push-bar (Lateral Support Bar)(Note 1)	10. Caster
2. Push Handle	11. Ergonomic Pillow
3. Reclining Lever (Black)	12. Attendant Brake (Red)
4. Back Joint	13. Back Upholstery
5. Backrest Support Unit (Note 2)	14. Armrest
6. Rear Wheel	15. Side Panel
7. Anti-Tip	16. Seat Upholstery
8. Brake	17. Swing-away Elevating Footrest
9. Cross Brace (Cross Bar)	18. Calf Pad
	19. Footplate

Note 1: Item 1 is optional for the markets that require the crash test. (affixed the labels of hook)

Note 2: Item 5 is optional for the markets that do not require the crash test.

3.3 Parts Description MVP 502 F14

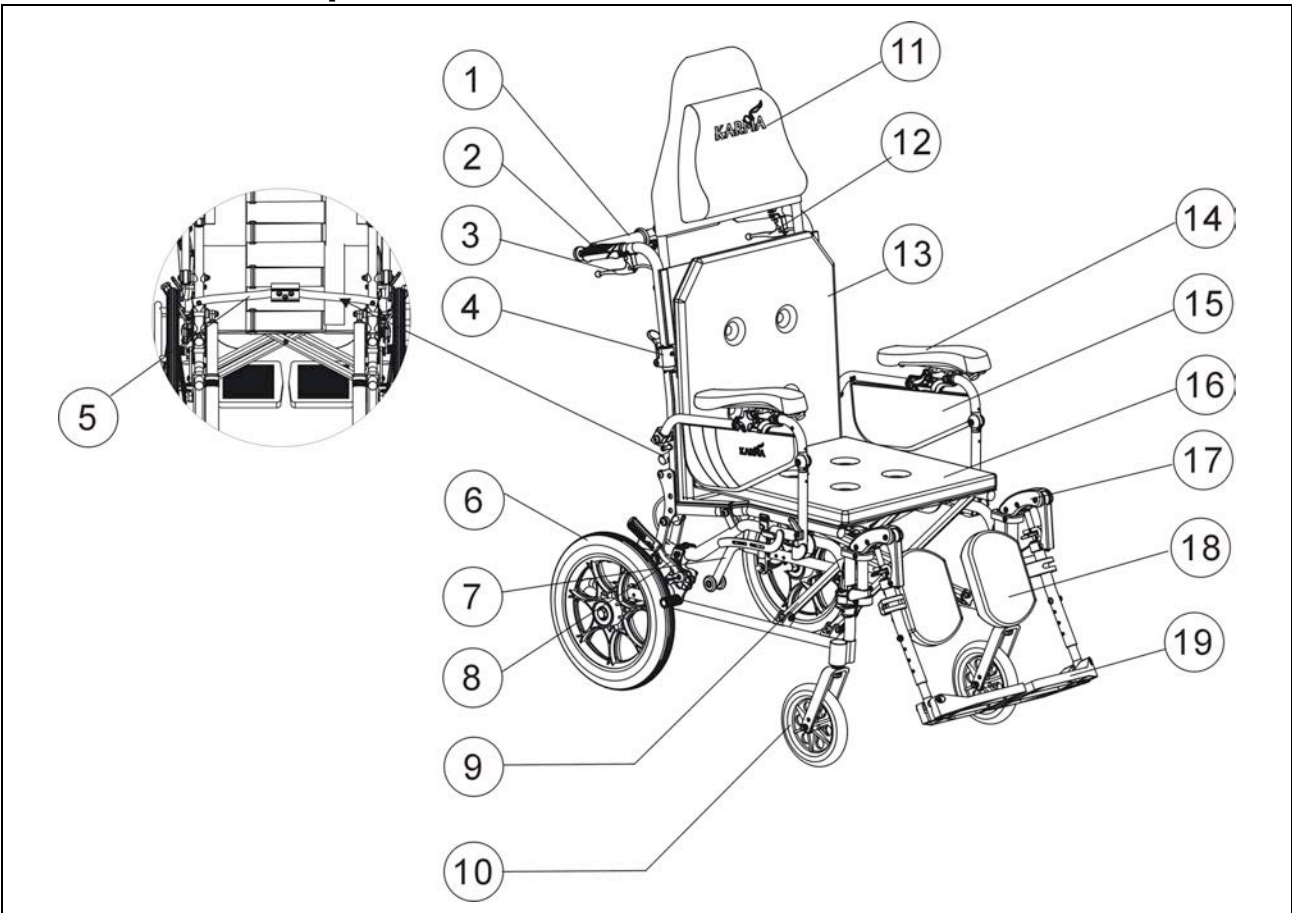

1. Rigidifying Push-bar (Lateral Support Bar)(Note 1)	10. Caster
2. Push Handle	11. Ergonomic Pillow
3. Reclining Lever (Black)	12. Attendant Brake (Red)
4. Back Joint	13. Back Upholstery
5. Backrest Support Unit (Note 2)	14. Armrest
6. Rear Wheel	15. Side Panel
7. Anti-Tip	16. Seat Upholstery
8. Brake	17. Swing-away Elevating Footrest
9. Cross Brace (Cross Bar)	18. Calf Pad
	19. Footplate

Note 1: Item 1 is optional for the markets that require the crash test. (affixed the labels of hook)

Note 2: Item 5 is optional for the markets that do not require the crash test.

4. OPERATION

4.1 Preparing For Use

4.1.1 Unfolding

Hold the grip and fold up the back joint, and you can hear a sound. (See Figure 4.1.)

Pointing your fingers inward with the palm of your hand on the frame, push down until the seat is fully lowered. Make sure the frame is firmly seated in its holder. (See Figure 4.2)

Push down the joint of the backrest support unit. (See Figure 4.3.) (option)

Push down the joint of the rigidifying push-bar, and you can hear a sound. (See Figure 4.4)(option)

Attach the upholstery to the chair. (See Figure 4.5)

Put the bracket of swing-away footrest into the front tube of frame. (See Figure 4-6.)

Put the footrest pivot into the end hole of front tube of frame. (See Figure 4-7.)

Swing the footrest to make the release pins fall into the hole of hanger lock base. (See Figure 4-8.)

Attach the headrest and tighten the knob bolts. (See Figure 4-9 and Figure 4-10.)



Figure 4.1



Figure 4.2



Figure 4.3



Figure 4.4



Figure 4.5



Figure4-6



Figure4-7



Figure4-8



Figure 4.9

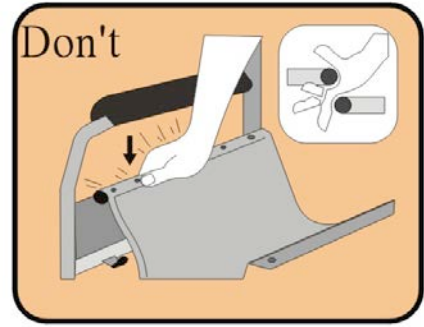

Figure 4.10



CAUTION:

Be careful! Do not get your fingers hurt when unfolding the wheelchair. (See Right Figure)



CAUTION:

Please make sure to tighten the knob bolts of the headrest, otherwise it might result in injury to the user or damage to the wheelchair. (See Figure 4.10)

4.1.2 Folding

Unscrew the knob bolts and then remove the headrest. (See Figure 4.11)

Flip up the calf pad. (See Figure 4.12)

Flip up the footplate. (See Figure 4.13)

Detach the upholstery. (See Figure 4.14)

Pull up the joint of backrest support unit. (See Figure 4.15.) (option)

Pull down the release pin and pull up the rigidifying push-bar. (See Figure 4.16.)

Pull up the front seat upholstery by holding the center between its front and back edge. (See Figure 4.17)

Press the two release levers on the backrest frame (push handle tubes) to fold the backrest down for compact storage and easy transport. (See Figure 4.18)

Swing the release lever outward (inward) and then detach the footrest. (See Figure 4.19 and Figure 4.20.)

Folding is now completed. (See Figure 4.21)



Figure4-11



Figure 4-12



Figure 4-13



Figure 4-14



Figure 4-15



Figure 4-16



Figure 4-17



Figure 4-18



Figure 4.19



Figure 4.20



Figure 4-21



Figure 4.22

4.2 Adjustments

4.2.1 Elevating footrest

You can elevate the footrest directly and stop at any position you desire. (See Figure 4.22)

When you want to lower it down, press the release lever, and hold the footrest tube to stop at where you desire. (See Figure 4.23)

To adjust footplate height, use Karma's tool provided to loosen the bolt at the side of the footrest tube. (See Figure 4.24)

Choose the height, tighten the screw, and make sure the footplate is firm. Then tighten the nut as a locknut from outside. (See Figure 4.24)

The calf pad can be adjusted upward and downward, forward and backward, rightward and leftward to suit the user's calf. (See Figure 4.25,4.26)



SUGGESTION:

Make sure that the footplate height is adjusted properly according to the user's calf length to reduce pressure on the body.

The footrest height must be at least 5cm above the ground. (See Figure 4.27)



Figure 4.23



Figure 4.24



Figure 4.25



Figure 4.26



CAUTION:

When adjusting footrest lengths, make sure the user's thigh is safe on the seat upholstery, and inner knee does not interfere with the front edge of seat upholstery. (See the Figure 4-28 and Figure 4-29)



Figure 4.27



Figure 4.28



Figure 4.29

4.2.2 Headrest

The ergonomic pillow may be adjusted to suit your height. Simply attach or detach it using the Velcro. (See Figure 4.30)



Figure 4.30



Figure 4.31



Figure 4.32

4.2.3 Upholstery

When upholstery is loose, you can tighten which by pulling and re-attaching the Velcro. (See Figure 4.31 and Figure 4.32.)

4.2.4 Reclining backrest 93°-160°

Please lock both brakes. (See Figure 4.33)

Grasp the right push handle and press the reclining lever (black) (See Figure 4.34)

Push the chair downward with both hands until the desired seat angle is achieved and then release the lever. (See Figure 4.35)



Figure 4.33



Figure 4.34



Figure 4.35

4.2.5 Flip-back armrest

You may flip back the armrest by pressing the release lever located at the front base of the armrest. Upon pressing the release lever, you can lift and flip the armrest backwards. (See Figures 4.36 and Figure 4.37)

Height adjustment : Simply unscrew the knob bolt, adjust the armrest height to the

desired position, and then re-tighten the knob bolt. (See Figure 4.38)



Figure 4.36



Figure 4.37



Figure 4.38

4.2.6 Rear Wheel

Your wheelchair may be supplied with quick-release wheels (option) If this is the case, please follow the instructions below.

4.2.6.1 Rear Wheel Removal

Support the weight of the chair with one hand by holding the push handle.

Press the hub button and hold down the quick-release mechanism.

Remove the wheel. (See Figure 4.39)

4.2.6.2 Rear Wheel Attachment

First ensure that the brake is at the OFF position. Take up the assembled wheel and axle and press the button in the centre of the axle. This action retracts the ball bearings that will allow you to push the axle into the wheel bracket that is located on the lower rear frame of the wheelchair. When you remove your thumb from the button on the axle, the ball bearings should be visible protruding from the axle at the back of the wheel bracket. This will secure the wheel safely on the frame. (See Figure 4.40)



CAUTION:

You should make sure that the axle is entirely mounted in the wheelchair bracket and that the ball bearings are fully open and have positively attached the wheel on the frame.

The rear wheel can be mounted at different positions on the frame to alter the seat height and overall stability of the chair. Changing the wheel position should be carried out by your approved repairer, technician, or therapist.



Figure 4.39



Figure 4.40

4.2.6.3 Important Do's and Don'ts

Do: Keep axles clean and lubricated with light oil or maintenance spray.

Do: Maintain correct tire pressure if using pneumatic tires.

Do not: Try to remove the wheels while the wheelchair is occupied even it is equipped with anti-tippers.

4.2.7 Safety Belt (Option) How to assemble and disassemble the Safety Belt

Loosen the fourth and fifth screws of both side of seat upholstery and insert the Safety Belt in between the fourth and fifth screw holes. (See Figure 4.41)

Keep the safety Belt at 45 degrees for comfortable usage. (See Figure 4.42)

Put the seat upholstery back and tighten screws.

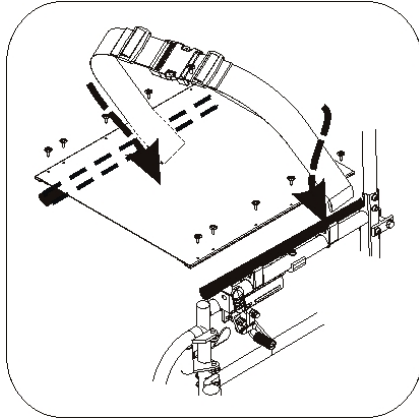

Figure 4.41

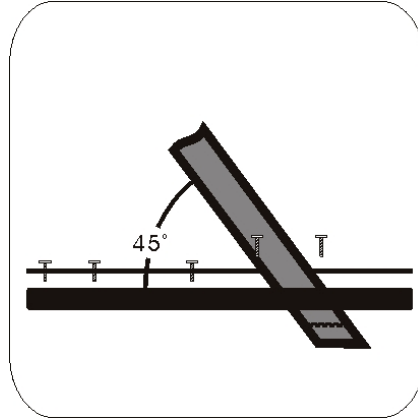

Figure 4.42

Adjusting length of seat belt

Push the two sides of belt through buckle so as to get the belt longer or shorter. (Figure 4.43 and Figure 4.44)

Pull the two sides of belt tightly. (Figure 4.45)

Push buckle up to the plastic clip so that the belt cannot slip out of its position. Do make sure that there is no gap between the clip and the buckle. (Figure 4.46)



SUGGESTION:

We recommend that the belt be fitted tightly around the pelvis. Please keep tighten the belt until there is a small space left between the user and the seat belt, which allows fingers only. Please check if the belt is fastened correctly as recommended. If you are not able to do so, please consult your supplier.



Figure 4.43



Figure 4.44



Figure 4.45



Figure 4.46

How to operate:

When you sit on the wheelchair, do fasten the safety belt.

Adjust the belt and make it fit your body for comfort and security.

When you are not using it, please fasten the belt to avoid the belt dropping into the rear wheels.

Maintenance

The safety belt is made of 100% polyester fiber and the clasp is made of plastics. It does not require any maintenance, but should be inspected each month to ensure that the edges are not frayed, and weekly to make sure that it fits the user correctly. If there are any signs of its being worn out, please replace it with a new one immediately.

4.2.8 Transport and Storage

Make sure the wheelchair is folded when stored.



SUGGESTION:

Please store the wheelchair in a location which is out of direct sunlight, rain, and dew. For more details, consult your Karma dealer.



WARNING:

Don't put anything on the wheelchair while it is in storage. Putting goods on a folded wheelchair will cause damage, which is not covered by its warranty. (See Figure 4.47)



Figure 4.47

4.3 Transferring In and Out

4.3.1 Transferring In

Engage both hand brakes.

Turn the footplates up and swing them to the side.

The user may get into the seat using the armrests as support.

Turn the footplates back down on which the user's feet can be placed. Release both hand brakes.



Caution:

Always ensure that the front casters are in line with the rear wheels and pointing forwards and that the back of the chair is secure either against a wall or firmly held by an attendant.

4.3.2 Transferring Out

Make sure that the chair is near your final destination.

Pull the chair backward to ensure that the casters are pointing forward, i.e. in line with the rear wheels and with the caster forks pointing forward all the time. Ensure that, where possible, the rear of the chair is against a wall or, if not, it is firmly held by an attendant.

Engage both hand brakes.

Turn the footplates up and swing them to the side.

Slide yourself forward on the seat.

Place one foot firmly on the ground with the knee at a right angle and the other foot slightly apart and further back.

Place your hands on the front of the armrests and move your weight forward, and bring your head and shoulders up over your knees as you push yourself up.



Caution:

Never stand on the footplates when getting into (or out of) the chair. (See Figure 4.40)

When getting in and out of the wheelchair, please use the hand brakes. The hand brake is the lever at the side of the wheelchair.

Please ensure that neither the tread on your tires nor the brake block has become overly worn. If pneumatic tires are used, please maintain at the recommended tire pressure for the same reason.

Please ensure that occupant's fingers do not get caught in the brake.

When transferring in and out of the chair, make sure that the brakes are applied to prevent the chair from moving away. You may also have the footplates flipped up for ease of entering or exiting. (See Figure 4.41)

4.4 General Use

4.4.1 Attendant Pushing and Self-propelled

Do ensure that the brakes are always applied when the chair is not being pushed. (See Figure 4.42)

Always make sure that both feet are safe on the footplates and that clothing is safely tucked out of the way and cannot get caught in the wheels. (See Figure 4.43)

Always use both hands on the push handles to control the chair. (See Figure 4.44)

Always avoid steep or uneven surfaces for the chair might tip over. (See Figure 4.45)

Always avoid soft surfaces for the casters might get bogged down. (See Figure 4.46)

Always be careful and not to go too fast or turn too quickly and try to maintain a smooth steady ride.

Before crossing the tracks, please stop completely and look both ways.

Cross the tracks perpendicular to avoid having your wheels get stuck.

Do not move at full speed while getting over railroad tracks.

Be careful when going through a doorway so that your hands and arms do not get injured.

PLEASE keep constant contact with the person in the chair. If you stop at a place to face a direction, remember to bring the chair into that direction so that the person in the chair does not have to turn the head.



WARNING:

NEVER apply the brakes all of a sudden as this might tip the user out of the chair.



Figure 4.48



Figure 4.49



Figure 4.50



Figure 4.51



Figure 4.52



Figure 4.53



Figure 4.54



Figure 4.55

4.4.2 Tilting by the Attendant

Make sure the user's feet are on the footplates and will not slip off. Make sure the handgrips are secure and cannot slip off.

Release both brakes.

Grasp both push handles firmly.

Put your stronger foot on the relevant tipping lever at the back of the chair.

Inform the person in the chair that you are about to tilt the chair backwards.

Pull the back with both hands and push down and forwards with the foot. This will bring the chair onto the back wheels. (See Figure 4.55)



Caution:

When a chair is tilted to about 25 degrees, it will balance on its rear wheels and be easy to hold. If it is tilted further back it will be difficult to hold and the person in the chair will feel unsafe.

Keep your back straight while lowering the chair; keep your foot on the anti-tipper and lower the chair slowly, forwards softly to the ground.

4.4.3 Tilting by the User

Make sure your feet are on the footplates and will not slip off.

Release both brakes.

Grasp both push rims and give a firm, sudden forward push immediately before the obstacle, continue the momentum (be ready to keep pushing) until the obstacle is mounted.



Caution:

This method should only be attempted by people experienced in wheelchair use. Strong arms are also necessary. It is always better to have the help of an attendant.

Leaning backwards causes the casters to rise higher BUT it is much safer to lean forwards and stay balanced.

4.4.4 Going Down Curbs

Please note: It is always better to avoid curbs where possible by using ramped curbs or slopes and this operation is best attempted with the aid of an attendant.

4.4.4.1 Going Down Curbs Forwards with and Attendant



Caution:

This is the more difficult method and can jar the user but allows a better view of traffic.

Be careful that the anti-tipper does not get caught on the curb causing the user to fall.

NEVER ALLOW THE CHAIR TO TIP FORWARDS WHEN GOING DOWN A CURB.

Position the chair so that the front casters are near the edge of the curb and make sure that the road is clear.

Move the chair slowly and carefully forwards while tilting it back slightly. Be ready to take the weight when the rear wheels cross the curb edge. Ensure that both rear wheels touch the ground at the same time to avoid tipping the chair.

Gently lower the front casters. AVOID JARRING THE USER.

4.4.4.2 Going Down Curbs Backwards with an Attendant



Caution

This is the easier and smoother method BUT it requires the attendant to step backwards into the road.

Back the chair to the curb edge and be careful that the back wheels are equally near the edge.

Grasping the push handles, gently lower the rear wheels onto the road. Be prepared to control the weight as it descends and ensure that the back wheels touch ground at the same time.

Tilt the chair back slightly and pull the tilted chair far enough into the road so that the casters and footrests can be lowered clear of the curb.

4.4.5 Going Up Curbs

Please note: This operation is best attempted with the aid of an attendant and the best method is to go up curbs forwards as this maintains the direction of travel and is physically less demanding for the attendant.

4.4.5.1 Going Up Curbs Forwards with an Attendant

As the footrests nearly touch the curb tilt the chair. The chair should be tilted just high enough to allow the front casters to roll smoothly onto the pavement.

Push the chair forward until the rear wheels are touching the curb. Then, continuing the movement, lift at the push handles while moving the chair forwards.

4.4.5.2 Going Up Curbs Backwards with an Attendant

Please note: for safety's sake we do not recommend using this method.

4.4.6 Up and Down Steps/Stairs

Please note: avoid flights of steps particularly if no extra help is available. Use ramps or lifts wherever possible.

Two attendants are necessary, each capable of carrying at least half of the combined weight of the person and the wheelchair.

Each helper should bend at the knees and grip the main frame: with the front attendants hands just under the front of the seat, with the back attendant's hands holding the frame just under the push handles.



Caution:

Don't attempt to lift the wheelchair by any removable (detachable) parts. Lifting by means of any removable (detachable) parts of wheelchair may result in injury to the user and/or assistant or damage to the wheelchair.

ALL LIFTING SHOULD BE DONE WITH A STRAIGHT BACK.

Straighten legs to lift the chair. Carefully carry it up or down steps; be aware of how you place your feet -- do not cross them and trip yourself up.

4.5 Transportation

The MVP502 has been crash tested to ISO7176-19 (Report No. MBK 09/0258) and is suitable for use in a vehicle that has been adapted for this purpose. The wheelchair must be securely restrained as described in this manual. The MVP was tested with a four point webbing system. For further information on the use of wheelchair restraints please refer to the manufacturer's user guide.

Karma always recommends that the user be transferred into car seat with a safety belt or harness while in a transport.



SUGGESTION:

Please transfer to a seat in the car if at all possible

4.5.1 Before use



CAUTION:

The MVP502 was tested with a four point webbing system, with the back in the upright position. Please leave the headrest in place during transportation.

Please detach all easily removable accessories from the wheelchair and stow them in a safe place where they cannot move around and become a safety hazard.

- A four point tie-down system should tightly fasten to the lower wheelchair frame marked



with a yellow sticker as pictured.

An occupant restraint system using both a pelvis and harness must also be fastened to the transport vehicle to insure user safety. Please refer to the restraint system's instructions.

The attendant / transporter must double-check all fastening points for proper connection and tightness to assure the wheelchair users safety. The attendant / transporter must be fully cognisant of the fastening system's usage and its weight limitations.

See <http://www.unwin-safety.com/> for more information.

4.5.2 Method of restraint

The MVP502 was tested with four point webbing systems, with the back in the upright position. Please refer to the restraint manufacturer's user guide for further details of its operation.

Fitting the front restraint

Connect the straps around the wheelchair frame and caster bracket as pictured below. The anchor point is marked with a yellow sticker.

Take the brakes off and reverse the wheelchair to tension the front straps. Apply wheelchair brakes (the brakes should be left on during transport)

Fitting the rear restraint

Attach rear straps into rail approximately 11.81 in. behind the wheelchair backrest.

Attached the hooks to the wheelchair brackets at the rear of the wheelchair as pictured below. Tension the restraint until the wheelchair is secure.



CAUTION:

The MVP502 was tested with a four point webbing system, with the back in the upright position. Please leave the headrest in place during transportation.



Fitting the front restraint



Fitting the rear restraint

Fitting seat beat

Fasten the 3 point safety belt around the user.

The occupied wheelchair should be located in a forward-facing configuration, with the parking brake applied.

Pelvic restraints should make full contact across the front of the body near the junction of the thigh and pelvic as pictured below (correct seat belt position).

Restraints should not be held away from body by wheelchair components such as armrest or wheels as pictured below (Incorrect seat belt position).

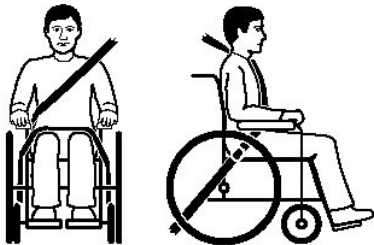

Correct seat belt position



Incorrect seat belt position

5. INSPECTION AND MAINTENANCE

5.1 Daily Check

Check the following items before traveling. If you find anything abnormal, visit your Karma wheelchair dealer for further inspection before using it.

Examine brakes, checking for wear, damage and misalignment. Replacing or adjusting the brakes should be carried out by your approved repairer.

Check that the hand grips are not damaged and are securely bonded to the push handles.

Check anti-tippers are not damaged and are securely attached.

Check that the anti-tippers' wheels and frame are not damaged and are securely mounted.

Check that the headrest screws are tightened.

Before using the wheelchair, make sure all nuts and bolts are tight. Check all parts for damage or wear and have a qualified technician replace it if necessary. Check all parts for proper adjustment.

Inspect brakes for proper operation.

The wheels and tires should be checked periodically for cracks and wear, and should be replaced by a qualified technician.

A qualified technician can be found with an authorized distributor/dealer.



CAUTION:

Visit a Karma wheelchair dealer for inspection and maintenance if you find anything abnormal.

5.2 Regular Maintenance Record

To make sure your wheelchair is in good condition, visit your Karma wheelchair dealer regularly for maintenance (and keep records accordingly) every six months after purchasing.

A maintenance/service fee may apply.



SUGGESTION:

Even if you don't use the vehicle for a long time, the wheelchair should still be maintained regularly. You should clean your wheelchair regularly to keep it beautiful and safe.

Item	Weekly	Monthly
GENERAL		
● Wheelchair rolls straight (no excessive drag or pull to one side)		V
FRAME AND CROSS BARS		
● Inspect frame structure for small cracks/fissures		V
● Inspect for bent frame or cross bars		V
BRAKES		
● Do not interfere with tires when rolling		V
● Pivot points free of wear and looseness		V
● Easy to engage	V	
● Prevent chair from moving when engaged	V	

HEADREST, SEAT & BACKREST		
● Inspect for rips or sagging	V	
● Inspect for loose or broken hardware		V
CASTERS		
● Inspect the casters for smooth rotation of the caster wheel and caster assembly		V
● Inspect the caster for wear in the bearings/mountings and for tire wear or damage		V
REAR WHEELS		
● Quick-release axles lock properly; lubricate if necessary	V	
● No excessive side movement or binding when lifted and spun		V
● Inspect for cracked, bent or broken spokes	V	
ARMRESTS		
● Inspect the detachable armrest button for effective locking		V
● Make sure the armrest detaches and flips back properly		V
● FOOTRESTS		
● Inspect the footplate height adjustment screws are securely tightened		V
● Inspect the swing-away footrest release lever for effective locking		V
TIRES		
● Inspect for flat spots, cracks and wear	V	
● If pneumatic tires, check for proper inflation	V	
● Check tire tread depth is more than 1mm		V
● Check tire pressure; tire pressures are located on the side of the tire	V	
 CAUTION: As with any wheelchair, the wheels and tires should be checked periodically for cracks and wear, and should be replaced. Failure to keep tires at the correct pressure will reduce the braking efficiency.		

 **CAUTION:**
Never disassemble or modify the wheelchair frame structure. Otherwise, injury or damage may occur. This will negate the warranty.

- Multi-purpose Safety Belt
 - Attaches to all Karma manual wheelchairs.

**CAUTION:**

Attaching accessories may alter the overall stability and center-of-gravity of the chair. Thus, this should be performed by your approved repairer and therapist.

7. TROUBLESHOOTING**Trouble or Problems with Your Wheelchair**

You can inspect the following before taking your wheelchair to a Karma wheelchair dealer.

Problem	Checking Points and Corrective Action
Chair Veers Right/Left	<ul style="list-style-type: none"> • Check tires for correct and equal pressure • Check caster bracket angle • Check that rear wheels are equally spaced from the seat frame
2. Sluggish Turn or Performance	<ul style="list-style-type: none"> • Check tires for correct and equal pressure • Check for loose nuts and bolts
3. Caster Flutter/Wobble	<ul style="list-style-type: none"> • Check tires for correct and equal pressure • Check for loose nuts and bolts • Check caster bracket angle
4. Squeaks and Rattles	<ul style="list-style-type: none"> • Check for loose nuts and bolts
5. Looseness in Chair	<ul style="list-style-type: none"> • Check for loose nuts and bolts

If you cannot solve the problem by yourself, contact your Karma wheelchair dealer for help.

8. SPECIFICATIONS

Model	MVP 502-F22		MVP 502-F14	
Overall Length (in)	45.67	45.67	45.67	48.03
Overall Width (in) F22	24.41	25.39	26.38	26.38
Overall Width (in) F14	24.02	24.80	25.59	25.59
Overall Height (in)	37.4/53.15	37.4/53.15	37.4/53.15	37.4/53.15
Total Weight (lb)	38.58			
Seat Width (in)	16	17	18	18
Seat Depth (in)	16	16	16	18
Seat Height (in)	20			
Backrest Height (in)	21.26			
Armrest Height (in)	9.06 ~ 11.42			
Calf Length (in)	16.97 ~ 20.98			
Overall Collapsed Length (in) F22	34.45	34.45	34.45	35.82
Overall Collapsed Length (in) F14	29.92	29.92	29.92	29.92
Overall Collapsed Width (in) F22	14.96	14.96	14.96	14.96
Overall Collapsed Width (in) F14	14.17	14.17	14.17	14.17
Overall Collapsed Height (in) F22	30.31	30.31	30.31	30.31
Overall Collapsed Height (in) F14	29.92	29.92	29.92	29.92
Total Weight (lb)	104.5(F22)	104.5(F22)	104.5(F22)	104.5(F22)
	97.2(F14)	97.2(F14)	97.2(F14)	97.2(F14)
Maximum User Weight (lb)	253		253	

Stability (According to ISO 7176-1:1999)

Forward Min. 27 degrees
 Backward Min. 15 degrees
 Sideways Min. 18 degrees

- The degree tolerance is +0, -1 degree.
- The test condition: size of test dummy used, 253 lbs.
- Please don't travel across a slope (in any direction) greater than 7 degrees.

9. CLEANING & RECYCLING**9.1 CLEANING**

In order to lengthen the life of your wheelchair, it is suggested that you clean the wheelchair periodically (if not daily), especially after it is used in the rain or snow. We suggest that you don't use your wheelchair in the rain or snow. If you are traveling and get caught in the rain, we suggest you try to find shelter while waiting it out. If you can't find shelter, proceed to your destination.

9.1.1 Frame

Wipe with a damp cloth.

9.1.2 Upholstery

When cleaning the upholstery, use warm water and a mild soap.

Upholstery cleaner/foam can also be used, but avoid other cleaning solvents.

9.2 POST-CONSUMER RECYCLING

A post-consumer recycling plan should follow the Environmental Protection Administration's regulations. The items listed below are for reference only as local laws and regulations may vary.

Material	Part Name	Method
Aluminum-alloy	Frame	Recyclable
Plastic	Modular Components	Recyclable
Paper	Owner's Manual	Recyclable

There are many organizations in many countries you can find on the Internet that will accept used goods for charity. Please search the information highway to help less fortunate individuals and protect our planet for future generations. If you do not have access to the world wide web please use your local phone directory, ask for operator assistance or go to your local government center for more information. Earth Day is every day.

Check with your local recycling center on where and how to recycle your wheelchair as this information varies from region to region.

10. WARRANTY**10.1 Serial Number**

To ensure after-sale service and warranty, please record and fill in the serial number which can be found on the frame.

Model	
Serial Number	

10.2 U.S.A. Limited Warranty Policy

Karman warrants the main frame of MVP-502 against defects in material and workmanship for the lifetime from the date of purchase, 6 months on parts.

Karman warrants the main frame of MVP502 against defects in material and workmanship for one year from the date of purchase, 6 months on parts.

This warranty is extended only to original purchasers of our products. Warranty is NOT TRANSFERABLE. Parts or materials which are subject to normal wear and which must be replaced/repared are the owner's responsibility and are not covered by warranty. Arm pads and upholsteries are not covered by warranty. It is recommended that wheelchair be returned to the authorized dealer through whom it was original purchased.

If within such warranty period, any such product is proven to Karman's satisfaction to be defective; such product shall be repaired or replaced at Karman option. In no case are goods to be returned without first obtaining an R.M.A. (Returned Merchandise Authorization) number issued by Karman and that the part in question is returned insured with freight prepaid to Karman, within the period of warranty. Labor charge incurred in the installation or repair of the above-mentioned parts plus all freight charges are not included in the warranty.

If Karman does not have a completed Warranty Registration Card on file for the consumer's product, then a copy of the invoice with date of purchase must be provided. The warranty period for the consumer commences on the purchase date from the seller. The warranty period for the seller, if the products are not to be sold to a consumer, commences on the invoice date from Karman Healthcare. The warranty is void on wheelchairs that have had the serial # tag removed or altered.

Products which have been subject to negligence, abuse, improper storage or handling, improper operation, unauthorized modifications or misuse are not covered by this warranty. Karman Healthcare will not warrant the frame or any parts damaged when the maximum weight limit is exceeded. Warranty applies in the U.S. only.

Karman Healthcare's sole liability extends to repair or replacement of parts or components as previously specified. The foregoing is in lieu of all warranties expressed, implied or statutory, whether written or oral.