

Lifetime Limited Warranty

If you have a question about your MOBB Healthcare device or this warranty, please contact an authorized MOBB Healthcare dealer.

MOBB Healthcare warrants to the original consumer purchaser for as long as they own their MOBB product that it will be free from defects in material and workmanship under normal use. This warranty is only applicable to products used in residential applications within the United States and Canada and is not transferable to subsequent owners. Should defects in material or workmanship exist during the applicable warranty period in any MOBB Healthcare Product, MOBB Healthcare will elect at its discretion to either repair or replace the defective material. This warranty covers only parts and materials of the products supplied by MOBB Healthcare. Not covered under this warranty are wear and tear items or abuse of the product in a manner that was not intended for the product to be used. This warranty shall become void if the product is in any way modified, improperly adjusted or abused.



Non-Tilt Overbed Table



Assembly Instructions

1. Remove contents from packaging and lay Table Top (1) upside down on flat surface with Mounting Bracket (5) facing upward. See Fig. 2.
2. Stand the Column Assembly (2) right side up as shown in Fig. 1. Ensure Trip Rod (15) is visible in the rectangular tube (as shown), but not protruding out of the top. If necessary, shake the Column Assembly (2) until the Trip Rod (15) drops into place inside the Column Assembly (2). Next, insert the Trip Lever (3), with rounded side facing up, into the Column Assembly (2) as shown, ensuring that the flat side of the Trip Lever (3) rests on the Trip Rod. (15)

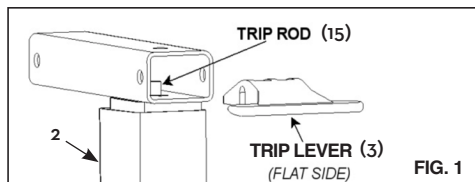

3. While holding the Trip Lever (3) securely in place on top of the Trip Rod (15), flip the Column Assembly (2) upside down and insert the Column Assembly (2) into the table top Mounting Bracket (5) as shown in Fig. 2.

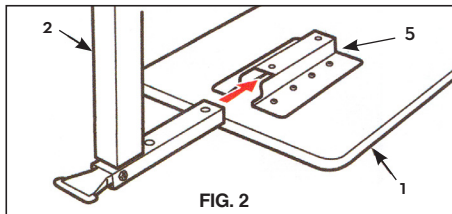

4. Align horizontal hole in table top Mounting Bracket (5) with horizontal hole in Column Assembly (2) and hole through Trip Lever (3). Insert 1/4 x 20 Bolt (4) into horizontal hole & secure with Nut (4). Tighten with 10mm wrench. See Fig. 3.

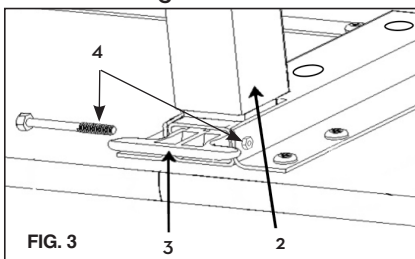

5. Install two Domed Phillips Head bolts and locking washers (6) through the vertical holes in the Mounting Bracket (5) and into the threaded holes in Column Assembly (2) as shown in Fig. 4.

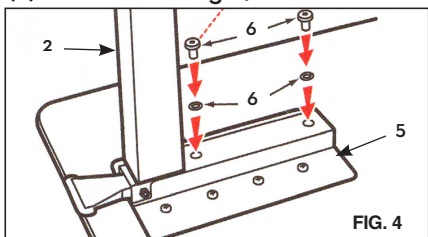

6. Install two Casters With Lock (8) into Base (7) which connects to Column Assembly (2). Install two Non-Locking Casters (9) into base opposite Column Assembly (2). See Fig. 5.

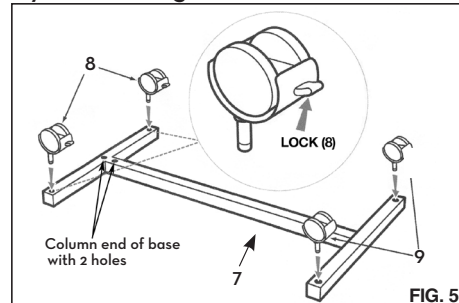

7. Install two Bolt Sleeves (10) into upside down Base (7) and then position two Bolts (12) through Bolt Plate (11) and into Bolt Sleeves (10). Position Base (7) over Column Assembly (2) and thread bolts into bottom of Column Assembly (2) and tighten using 16mm wrench. See Fig. 6.

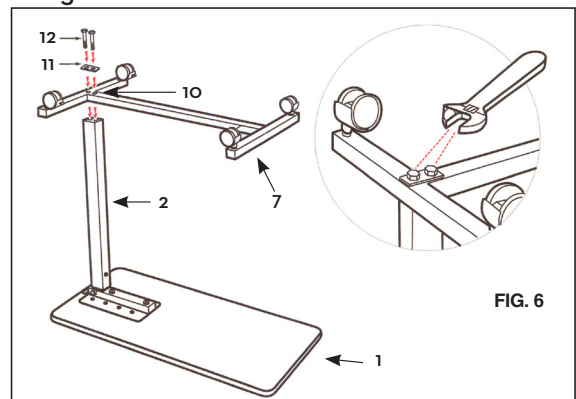

8. Turn the table upright and stand on casters.
9. **CAUTION:** This step must be completed last to prevent damage to the spring loaded mechanism. Remove the Black Screw (13) in the Column Assembly (2) collar labeled "Remove for Assembly" and replace it with the Chrome Screw (14) contained in hardware package. Do not remove Chrome Screw labeled "Do Not Remove". See Fig. 7 and Fig. 8.

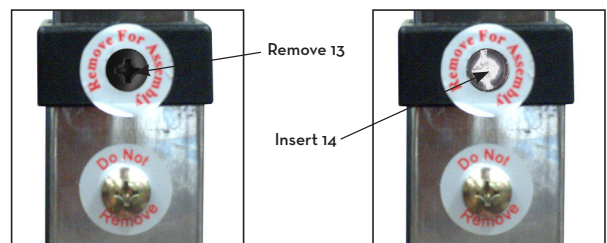

WARNING

FOR SAFETY – DO NOT REMOVE BLACK SCREW (13) ON COLUMN ASSEMBLY (2) UNTIL THE TABLE IS FULLY ASSEMBLED AND STANDING IN UPRIGHT POSITION. AFTER REMOVING BLACK SCREW, REPLACE WITH CHROME SCREW (14) INCLUDED IN HARDWARE PACKAGE.

THE BOTTOM CHROME SCREW WITH THE "DO NOT REMOVE" LABEL SHOULD NEVER BE REMOVED AS IT WILL DAMAGE THE UNIT AND VOID YOUR WARRANTY"

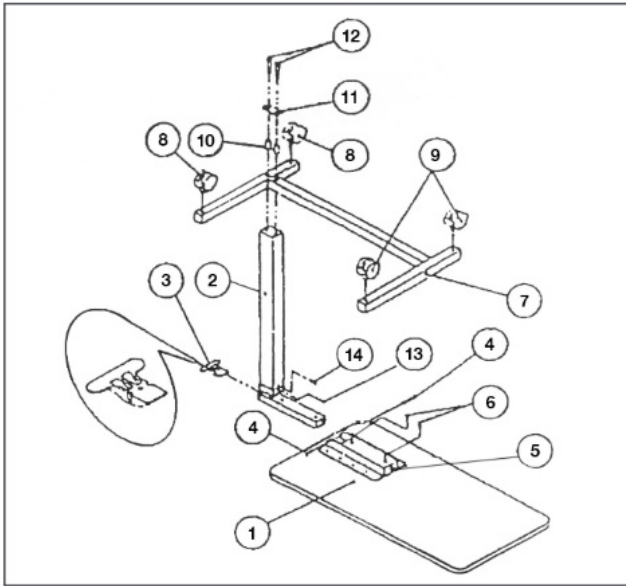

Operating Instructions

1. To raise top to desired height, apply light pressure upward at any point under table.
2. To lower, squeeze trip lever (3) up towards top and push down at column to desired height. Do not put pressure on tabletop end that is opposite the column. Column assembly will lock upon release of trip lever.

Assembly Precautions

This Overbed Table utilizes a high-tension spring loaded mechanism to raise the table, DO NOT remove #13 Black Screw and replace with #14 Chrome Screw until table is fully assembled.

DO NOT over tighten bolts, screws or use power tools when assembling this product.

Important Warnings

Please follow all instructions and warnings to avoid hazardous situations that can result in property damage and/or patient/resident/staff/caregiver injury and/or death.

Inspect the product for damage and loose hardware before each use. DO NOT use the product if it appears to be damaged or unstable and DO NOT modify the product in any way.

Intended Use

This product is designed for use as a movable patient/resident table top surface for reading, eating, or keeping small personal items such as glasses, telephone, or books within easy reach.

This product is designed for indoor use ONLY within close proximity of skilled caregivers. It is not designed to hold electrical items (such as televisions, computer monitors, coffee pots, etc.) and should not be used near open flames and excessive heat.

Maximum weight limitation for this product is 50 lbs (22 kg.); weight should be evenly distributed over the table top surface while at the lowest usable height to help maintain a stable condition.

DO NOT overload the product as that could result in breakage, as well as damage to property and/or serious injury.

Use ONLY as directed for its intended use. This product should NOT be used: as a sleep surface; as a walker or mobility aid to assist a person in walking, sitting down or standing up; to prevent or brace a person's fall; or to help transport persons or items.

Parts List

- | | |
|---|--|
| 1. Table Top | 9. Casters without Lock (2 each) |
| 2. Column Assembly | 10. Bolt Sleeves (2 each) |
| 3. Trip Lever | 11. Bolt Plate |
| 4. 1/4 - 20 x 2 1/8" Bolt & Nut (1 each) | 12. 3/8 - 15 x 2" Bolts (2 each) |
| 5. Mounting Bracket (Top to Column Assembly) | 13. Black Screw |
| 6. 1/4 - 12 x 1/4" Domed Phillips Head Bolt & Lock Washer (2each) | 14. Chrome Screw (to replace #13 black screw) |
| 7. Base | 15. Trip Rod 1/4" x 20 1/2" (inside Column Assembly) |
| 8. Casters with Lock (2 each) | |

