

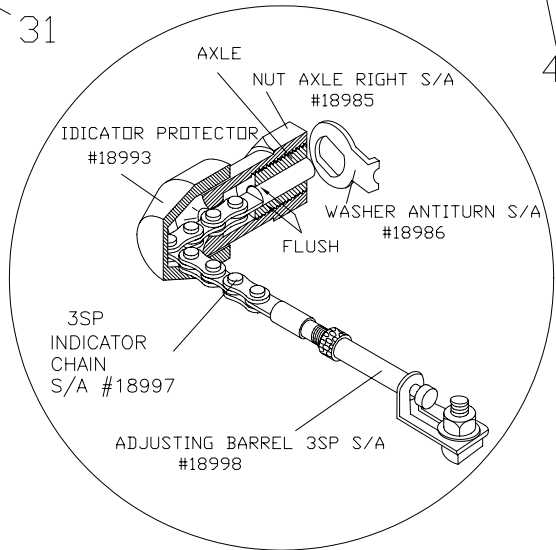

20" & 26" INDUSTRIAL HEFTY HAULER.

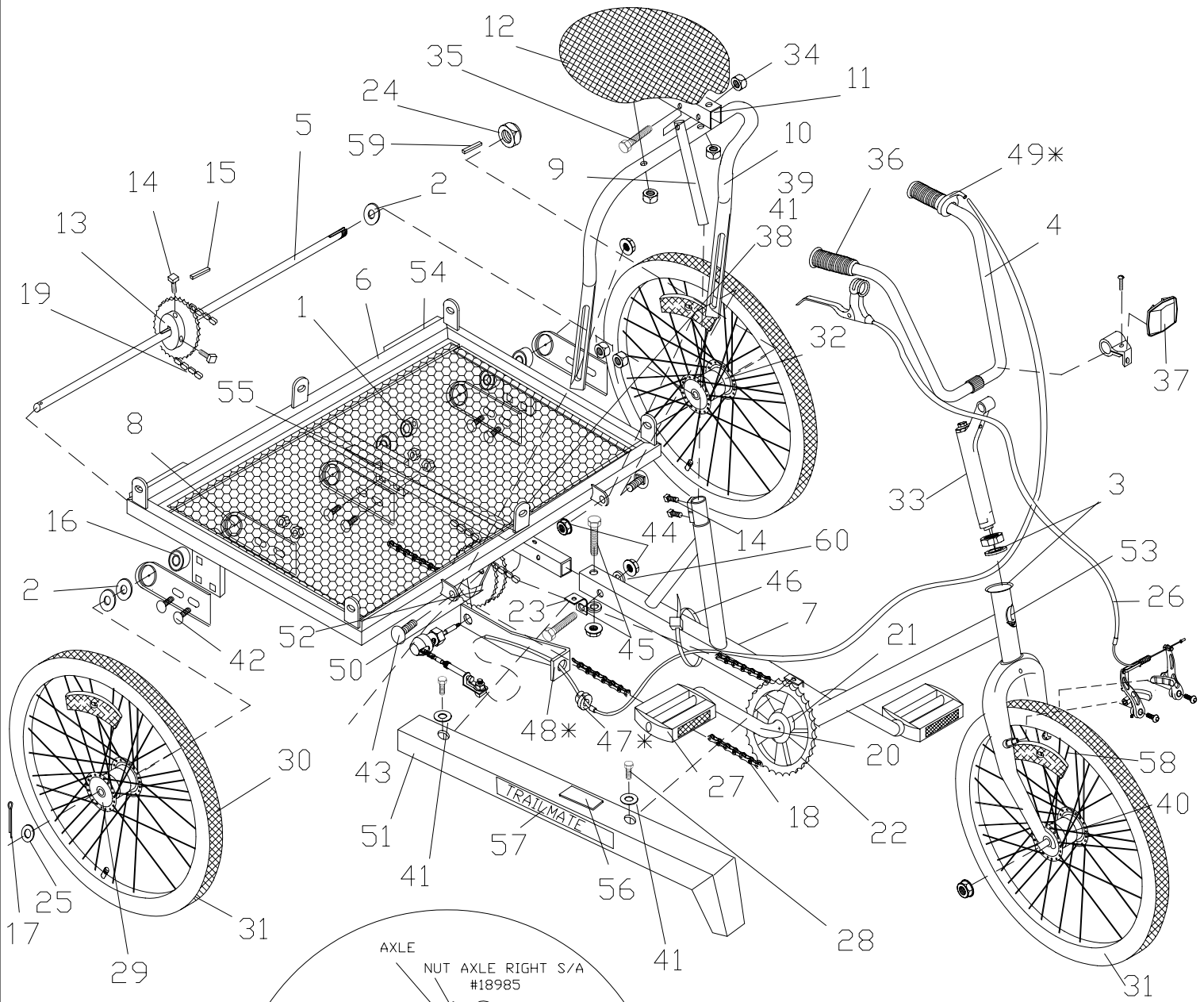

3 SPEED COASTER BRAKE OPTION

**INDUSTRIAL 20" & 26" HEFTY HAULER PARTS LIST**

ITEM NO.	PART NO	DESCRIPTION	QTY.	ITEM NO.	PART NO	DESCRIPTION	QTY.
1	12241	SET COLLAR 5/8	1	30	11985	RIMSTRIP 26X1.75	3
2	19640	WASHER 5/8 SAE	4		11984	RIMSTRIP 20X1.75	3
3	11831	HEAD SET COMPLETE	1	31	20156	TIRE 26X2.125 W/TPTUBE	3
4	11805	HANDLEBAR HI RISE #8890M-TRK/LR	1		19356	TIRE 20X2.125 W/TPTUBE	3
5	20144	AXLE DRIVE HEFTY HAULER 26"	1	32	20152	WHEEL 26" INDUSTRIAL DRIVE	1
	19669	AXLE DRIVE INDUSTRIAL 20"	1		19685	WHEEL 20" INDUSTRIAL DRIVE	1
6	19670	BACK FRAME TUBE ASSY IND	1	33	11815	STEM 12" LOW RIDER/IND TRIKE	1
7	20143	FRAME TUBE ASSY FRT HEFTY HAULER	1	34	12175	NUT 5/16-18 FLANGED	7
	19693	FRAME TUBE ASSY FRT 20" INDUSTRIAL	1	35	12212	SCREW 5/16-18X1-1/2HHCS GR 5	1
8	18220	AXLE BEARING HLD RR JR/JUNR/DJ	5	36	11801	GRIP BLACK 7/8 #40-0203-055	2
9	20146	SEAT POST 10"X1"	1	37	19715	REFLECTOR KIT INDUSTRIAL	1
	12076	SEAT POST 9"	1	38	12193	SCREW 10-32X1 PHIL PAN HD MS	1
10	12075	SISSY BAR DESOTO STATE COLOR	1	39	12170	NUT 10-32 HEX KEPS	1
11	11898	BRACKET WESTERN SADDLE	1	40	12032	WHL 26X2.125X36X0105 FRONT	1
12	11894	SEAT WESTERN SADDLE-DES/LR	1		11016	WHL 20X2.125X0105 FRT	1
13	11952	SPROCKET 22T SOLID W/ADAPTER	1	41	12229	WASHER #10 FLAT	6
14	11071	SET SCREW 5/16-18X3/4 SQ HD	4	42	12215	SCREW 5/16-18X3/4 CARRIAGE	6
15	12246	KEY SQUARE 3/16X5/8	1	43	12218	SCREW 3/8-16X3/4 SHT NEK CARR	2
16	11643	BEARING SP 99502HNR	5	44	12178	NUT 3/8-16 FLANGED	4
17	11139	PIN COTTER 1/8X1	1	45	12213	SCREW 5/16-18X2 HHCS	2
18	20168	CHAIN IND LONG 121 PITCH W/CL 26"	1	46*	12269	TIE CABLE BLACK 8X0.18	3
	19682	CHAIN IND LONG 143 PITCH W/CL 20"	1	47*	12285	HUB 3SPCB PLASTIC STOP #37201	1
19	12934	CHAIN IND SHORT 67 PITCH W/CL	1	48*	20141	HUB HOLDER 3SPCB CABLE GUIDE	1
20	11696	CRANK 6-1/2	1	49*	20163	GRIP SHIFTER W/CBL 1900MM-IND	1
	11695	CRANK 5-1/2	1	50*	18913	HUB 3 SPCB TRIKE W/22 SPKT S/A	1
21	11697	CRANK SET COMPLITE	1	51	20145	CHAINGUARD HEFTY HAULER 26"	1
22	11934	SPROCKET 36T 1/2X1/8-TRK/EZ/FC	1		19686	CHAINGUARD INDUSTRIAL 20"	1
23	20148	CHAINGUARD BRKT HEFTY HAULER	1	52	11667	HUB CB TRIKE SHIMANO	1
24	11115	NUT 5/8-18 JAM	1	53	11718	DECAL TM HEAD	1
25	12240	WASHER SPSE1X41/64X.062	1	54	17380	REFLECTOR JUNIOR JR SIDE RED	2
26	18227	BRAKE CABLE JR/JUNR/DL 34X42	1	55	19325	DECAL "DO NOT STAND ON CYCLE"	1
	19684	BRAKE CALIPER IND ASSY FRT	2	56	14089	DECAL AVOID SHARP TURNS	1
27	11857	PEDAL 1/2" PR #643P10E141	2	57	11719	DECAL TM CHAINGUARD	1
28	12188	SCREW 10-32X3/8 SLTD HWH T/F/S	2	58	14248	FORK 20" MWT STATE COLOR	1
29	20151	WHL 26X2.125 SPOKED ZINC W/BEARING	1	59	20012	KEY SQUARE 3/16X1-1/4	1
	19347	WHL 20X2.125 SPOKED ZINC W/BEARING	1	60	12235	WASHER 5/26 USS	2
				61	20247	OPT. EXT. SEAT POST & SISSY BAR	1

\*-- 3 SPEED COASTER BRAKE ONLY

Literature Kit #20142 & #19692 (10-03-06)

# ASSEMBLY 20" & 26" INDUSTRIAL HAULER.

1. Remove back (6) and front (7) frame assemblies from carton.
2. Slide back frame assembly (6) in to front frame assembly (7) fasten securely using bolts (45) and nuts (34).
3. Remove, the outside cotter pin (17) and washer (25) from right axle, install wheel with bearing (29) and fix in place with cotter pin and washer.
4. Install left wheel (32) on axle, using washer (2), key (59), and nut (24)
5. Install the long chain (18) on front sprocket (22).
6. Install chain guard (51).
7. Install handlebar assembly (4).
8. Fasten seat (12) and sissy bar (10) on frame
9. Install pedals (27).
10. Adjust seat and tighten securely with screws (35) and nut (34).
11. Fasten cable to frame with tie cables (46).

## Option Front Basket.

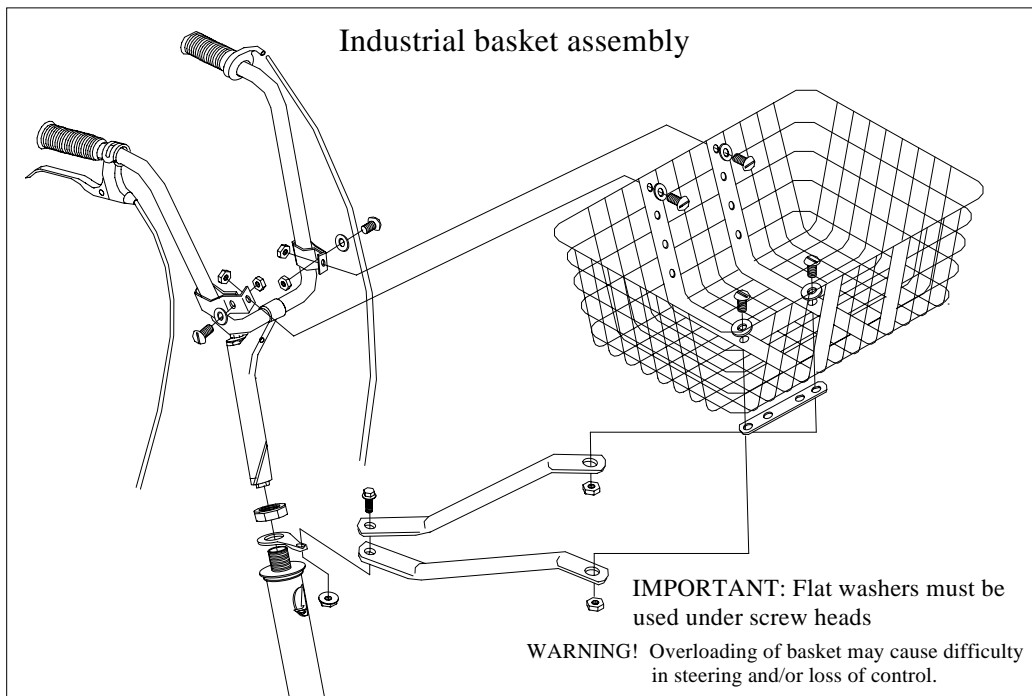

### **Industrial Hauler**

*This is a recreational unit, not designed for excessive speeds or misuse.  
Careless operation may cause ride to lose control and result in serious injury.  
Do not brake or turn at high speeds; this may cause to roll-over and rider injury.*

### **Things to know before riding you cycle:**

1. Know your local bicycle laws and wear a helmet.
2. Do not exceed the recommended weight limit 500 lbs.
3. Do not stand on unit.
4. Wear light-colored clothing.
5. Do not ride at night.

# MAINTENANCE AND INSPECTION

---

## REGULAR MAINTENANCE: Bi-Monthly

1. Keep all painted parts cleaned and waxed for along-lasting luster.
2. Lubricate the following:
  - Axle shafts
  - Chain- turn pedal crank forward and spray freely.
3. When storing over prolonged periods, turn upside down to prevent flats from occurring on the tires. If stored outside, cover to protect finish and moving parts.

---

## PREVENTIVE MAINTENANCE: Every Six Months

These are services that should be performed by you local bicycle shop. A fee may be charged.

1. Check tires for wear, rim cuts and valve core alignment (usually caused by improper air pressure)
2. Check wheels for cracks and alignment.
3. Check brakes for proper operation.
4. Check and repack all bearings and adjust all cones.
5. Check for worn bearings, cones and cups.
6. Check chain for adjustment and clean as needed.
7. Check for loose bolts and nuts.

Attention: While your unit is new, some noises may occur when the unit is breaking in. Should they continue for more than 30 days, see local bike shop.

---

## INSPECTION

Check the following, as it applies to your cycle, on a regular basis:

1. Hand Brake: Make sure the brake engages, by squeezing the hand brake.
2. Wheels: Check wheels for alignment.
3. Pedals: Inspect pedals and make sure pedals is tightly attached to crank.
4. Handle grips: Replace worn or loose grips.
5. Chain: Check for proper tightness. Replace damaged chain immediately.
6. Seat: Adjust seat for ride comfort and safety.
7. Tires: Keep tires inflated to the recommended tire pressure, as indicated on the tire's sidewall.
8. Frame: Replace damaged frame immediately.



Trailmate

# INSTALLATION GUIDE

## 3-Speed Coaster Brake Kit #19749

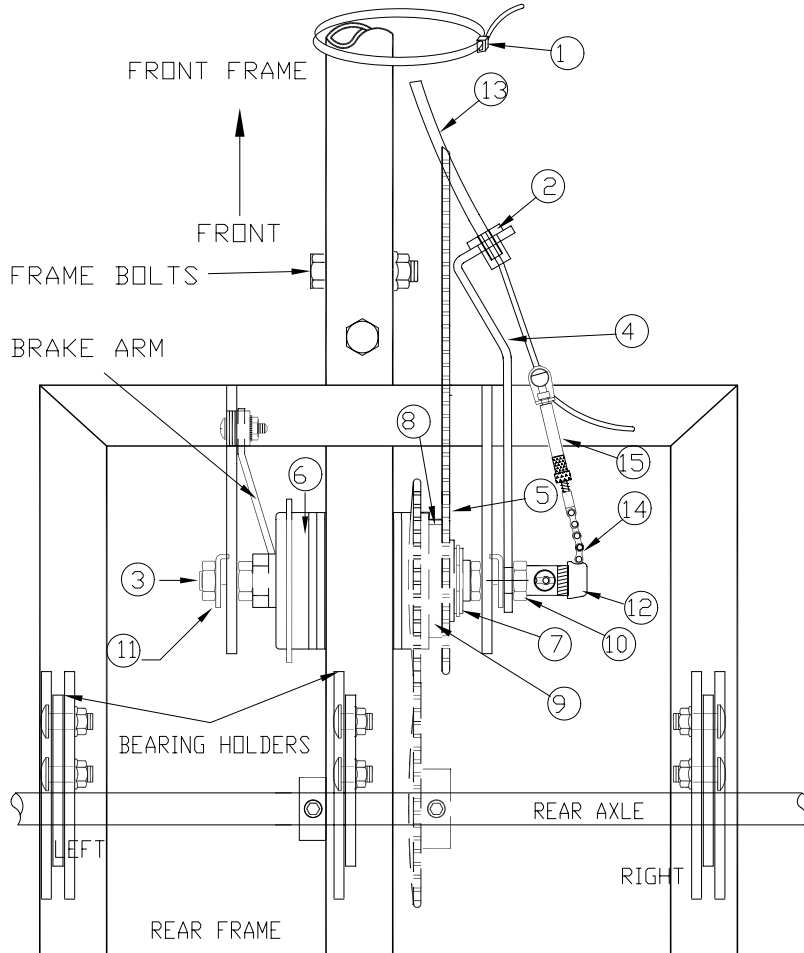

Check to make sure that you have all parts.

### Parts Listing:

1.	12269	Cable Ties	3
2.	12285	Plastic Cable Stop S/A	1
3.	18049	Nut Axle S/A	1
4.	18746	Hub holder 3spcb cable guide	1
5.	18909	Sprocket 21T S/A	1
6.	18913	Trike 3-spd CB Hub w/22 Tooth Sprocket	1
7.	18982	Snap Ring S/A	1
8.	18983	Dust Ring S/A	1
9.	18984	Washer Sprocket Spacer	1
10.	18985	Nut Axle Right S/A	1
11.	18986	Hub Axle Antiturn Washers S/A	1
12.	18993	Indicator Protector	1
13.	20163	Grip shifter 3sp w/ cable	1
14.	18997	Indicator Chain S/A	1
15.	18998	Adjusting Barrel S/A	1
16.	19713	Grip shifter plastic washer	1
17.	19714	Grip shifter instruction sheet	1
18.		Installation Instructions	1

### Kit Installation Preparation

Remove chainguard. Loosen the frame, bearing holder and CB hub bolts . Remove chains. Remove CB hub.

#### Step 1

Install the 3-sp CB Hub (6) into the open-ended slot. Refer to drawing for the location of hub (6) and correct hub position. Make sure the sprockets line up properly.

#### Step 2

Install front chain around crank sprocket and outside sprocket on brake hub. Install rear chain on solid sprocket on rear axle. Slide frame assembly apart until chains are tight. Tighten the frame nuts first and then axle nuts. NOTE: When tightening nuts, make sure that frame and hub are straight and not out of alignment. Tighten the nut and screw on the brake arm. Install chainguard.

#### Step 3

Install grip shifter (13) onto left side of handlebar. Fasten plastic cable stop (2) to hub holder cable guide (4). Run cable from grip shifter down along main frame tube and into plastic stop. Secure cable housing to frame tube with cable ties (1).

#### Step 4

Refer to drawing and Diagram 1 of Sturmey Archer Installations Instructions for connecting cable to hub and gear adjustment.



**Trailmate**

1851 67<sup>th</sup> AVE East

Sarasota, FL 34243

Tel: (941) 755-5511

Fax: (941) 758-5141

Visit us @ [www.trailmate.com](http://www.trailmate.com)

**For service or to order  
replacement parts  
please contact your  
local Trailmate dealer.**

# INDUSTRIAL

This is a recreational unit, not designed for excessive speeds or misuse.

Do not brake or turn at high speeds. This may cause cycle to roll over. Careless operation may cause rider to lose control and result in **serious injury**.

## Things to know before riding your cycle:

1. Know your local bicycle laws and wear a helmet.
2. Do not exceed the recommended weight limit of 500 lbs.
3. No more than one rider at one time.
4. Do not stand on unit.
5. Be sure to install safety flags.
6. Wear light-colored clothing and protective gear.
7. Do not ride at night.
8. Children must be supervised by an adult at all times.

### Trailmate Limited Warranty

Trailmate, Inc., guarantees each cycle product against all defects in materials and workmanship for a period of 90 days from date of purchase. Tires and tubes are not covered by this guarantee.

During this period, any part that is judged by the makers to be defective will be replaced free of charge. Any failure resulting from accident, abuse, neglect, normal wear, or improper assembly or maintenance by the owner is not covered.

Trailmate, Inc., further authorizes a lifetime frame guarantee and will replace any frame, at no cost to the buyer, providing that item has not been used for rental use and that:

- 1) The item has not been altered, repaired, or modified in any way.
- 2) The item has not been subject to misuse, negligence, and/or an accident.
- 3) Original ownership is established.

Any parts under this guarantee on which claims are entered shall be returned for inspection with transportation charges prepaid by the claimant. Replacement parts will be shipped F.O.B. factory.

There are no warranties or guarantee, expressed or implied, written or oral, which extend beyond the description on the face hereof.