



LUMBAR SUPPORT, SHORT

Rx Only — Single Patient Use Only



Instructions for Use

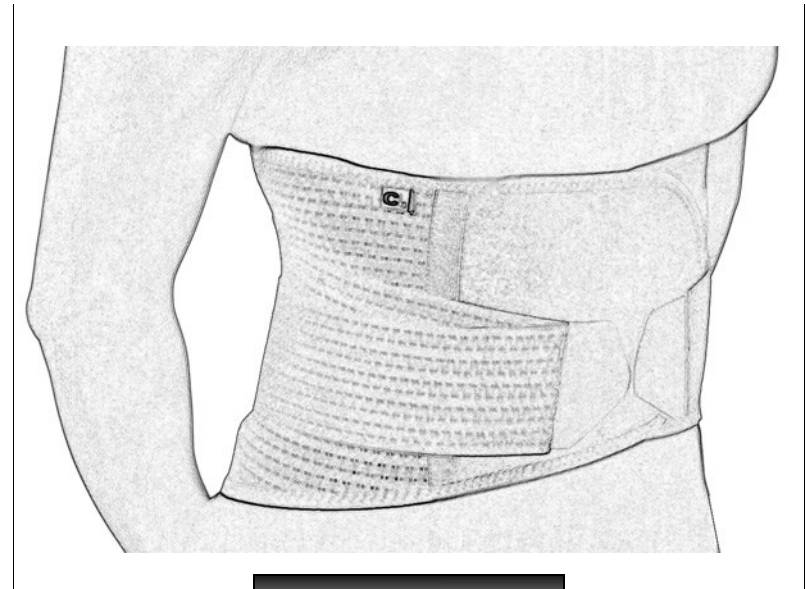

FEEL THE FUNCTION

The intended function of this support is to relieve stress on the lumbar spine. This is accomplished by using compressive forces to lift and/or help the abdominal muscles provide support to the lumbar spine. Review instructions on inside page carefully before application.

Lumbar Support, Short

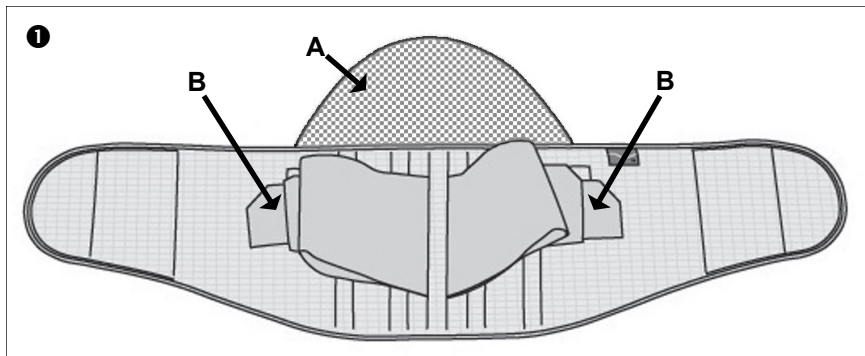

1. Place optional back pad, "A", mesh side up, under the open support as shown. Make sure two small straps, "B", on the outside are loosened.

2. With white tag on top and inside, center support on small of back. Grasp ends of wide elastic and stretch support away from your body. Wrap the main part of support around waist and secure in front, low and tight.

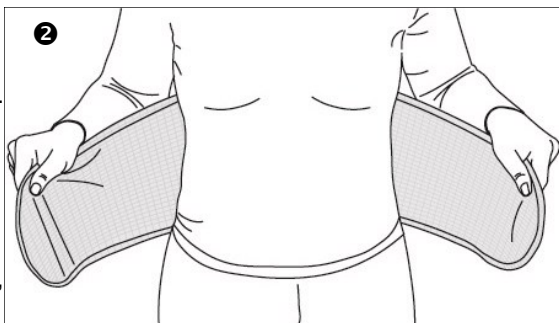

3. Locate small elastic straps that were loosened in step 1.

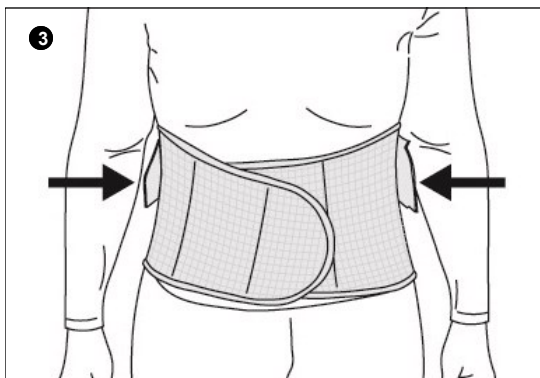

4. Grasp small straps and pull them down and away from your body.

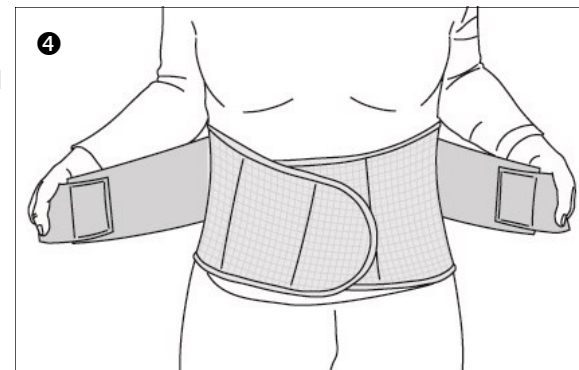

5. Finish wrapping the small straps around and secure. Small straps should land on bottom half of support as shown.

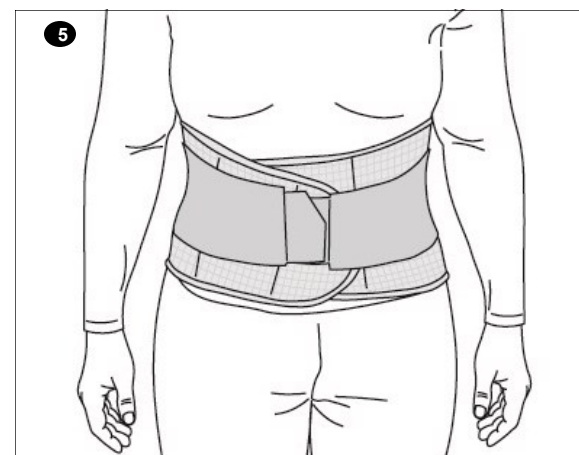

Indications / Intended Use

Moderate to severe low back pain, lumbar sprains & strains, lumbar muscle weakness, lumbar instability.

Contraindications

Poor peripheral circulation, diabetes or decreased skin sensitivity.

Adjustment

This brace should only be fitted by a licensed medical professional.

Warning

Do not overtighten, as this can cause poor circulation and/or skin irritation. If you feel any irritation, observe skin discoloration, or experience other problems such as excess swelling, remove brace and consult your healthcare professional. Check skin on a daily basis.

Wash instruction

Hand wash in cold water using mild detergent. Air dry.