

# karma

A Better Wheelchair, A Better Fit



## Manual Wheelchair Owner's Manual

### Flexx Series

(KM-8022/KM-8522)



**ISO 9001**



---

## GENERAL WARNING

- e DO maintain your chair well, in particular check the tire pressure since this affects the efficiency of the brakes. To know the correct tire pressure, please see the walls of the tires.
- e DO make sure both brakes are applied before getting in or out of the chair.
- e DO make sure both brakes are applied when the chair is not being pushed or used.
- e DO take care when climbing kerbs or turning on slopes.
- e DO avoid steep or uneven surfaces that may cause the chair to tip over.
- e DO avoid soft surfaces because the castors may become bogged down.
- e DO travel smoothly in all conditions.
- e DO look well ahead to anticipate hazards such as furniture, doors, potholes, etc.
- e DO make sure that both feet are safely on the footrests and that clothing is safely tucked out of the way so that it cannot get caught in the wheels.
- e DO take care when traveling up or down or across inclines.
- e DO keep both hands on the push handles to control the chair, if you are the attendant.
- e DO pay attention to keep the wheelchair balanced.
- e DO check the frame and components regularly and refer to this user guide during and after the warranty period.
- e DO tie-up the upholstery or replace which with a new one when it becomes loose.
- e DO lubricate bearings regularly.
- e DO equip with anti-tippers to avoid falling backwards.
- e DO equip with a seat belt designed for disabled people.
- e DO equip with "ankle supports" for disabled people.
- e DO clean both hands after oiling the wheelchair.
- e DO keep far away from flame.
- e DO tighten the screws of headrest tubes (if applied).
- e DO NOT overload the chair in any circumstance.



- 
- e DO NOT hang anything heavy on the back of the chair that could cause the chair to become unstable, particularly when negotiating inclines.
  - e DO NOT allow more than one user at a time.
  - e DO NOT use with an unconscious patient.
  - e DO NOT use other transport to pull the wheelchair.
  - e DO NOT do "wheelies", as you may fall or tip over backwards and suffer a severe injury.
  - e DO NOT sit in a wheelchair within a moving vehicle unless it has affixed the labels of hook mark.
  - e DO NOT go too fast or turn too quickly.
  - e DO NOT stand on the footplates when getting in or out of the chair.
  - e DO NOT go down steps forward, whether solo or with an attendant.
  - e DO NOT attempt to lift the wheelchair by any removable (detachable) parts. Lifting by means of any removable (detachable) parts of the wheelchair may result in injury to the user and/or assistant or damage to the wheelchair.
  - e DO NOT use the wheelchair when the back is folded. This alters the centre of gravity and may cause the wheelchair to tip backwards. The back should only be folded for storage or transport of the wheelchair.
  - e DO NOT hang anything on the back joint that could cause the backrest folding suddenly and may cause injury.

## **YOU AND YOUR KARMA SERVICE PROVIDER**

- e No tools are required for assembly. Your wheelchair should be assembled by your authorized KARMA dealer. Your authorized KARMA dealer is also your service provider. Unauthorized repairs, upgrades and add-ons will void your warranty. Anything wheelchair related that requires tools should be done by your authorized KARMA service provider. Your KARMA service provider has the necessary service/maintenance manual for your wheelchair.
- e If you have any defective parts or lose any parts, please contact your dealer for repair and/or replacement. Please only use parts authorized by KARMA. Use of parts that are not authorized by KARMA will void your warranty.



- 
- e Part numbers are listed on our bill of materials (explosion drawings), which we give to our authorized dealers and service providers. Customers should order parts through their dealer as well as all repairs and scheduled maintenance.
  - e Customers should go to their dealer for all service needs to guarantee their warranty is not void. Always go to an authorized service provider. Unauthorized repairs will void your warranty. Procedures other than those described in this manual must be performed by a qualified technician. They also have the service manual with a complete list of maintenance required to keep your KARMA wheelchair in top performance. Please check the warranty section of this manual to find out what KARMA guarantees and what maintenance and parts that are not covered by our warranty.
  - e KARMA does not have an official list of service providers at this time. Please contact your dealer for service. If you cannot contact your dealer, please contact another authorized KARMA dealer for service. If all else fails, contact KARMA directly via our website or give us a call and we can refer you to your new service provider.

## CE MARKING

- e This wheelchair complies with the requirements of the Medical Devices Directive 93/42/EEC.

### CAUTION:

- e **When prescribing wheelchairs for use by full or partial amputees (above or below knee, single or double) or other conditions that affects the user's natural center of gravity and might cause the wheelchair to tip or the person on the wheelchair to fall off, we suggest contacting your therapist or dealer as well as attaching anti-tippers, pelvic belt, or other additional safety accessories.**
- e **Anti-tippers MUST be equipped when the backrest angle is set as greater than or equal to eight degrees.**

# TABLE OF CONTENTS

1. PREFACE.....	1
2. SAFETY.....	1
2.1 Before Using.....	1
2.2 While Moving.....	1
2.3 General.....	4
2.4 Upholstery.....	4
2.5 Anti-Tippers.....	4
2.6 Maximum User Weight Limit.....	4
2.7 Avoid General Misuse.....	5
2.8 Labeling.....	6
3. INTENDED USE & PARTS.....	7
3.1 Intended Use.....	7
3.2 Flexx Parts Description.....	8
4. OPERATION.....	9
4.1 Preparing For Use.....	9
4.2 Getting Into Your Wheelchair (See figure 4.17).....	11
4.3 Getting Out of Your Wheelchair (See figure 4.18).....	12
4.4 Rear Wheel Disassembly.....	12
4.5 Rear Wheel Assembly.....	12
4.6 Backrest Angle Adjustment.....	13
4.7 Seat Depth Adjustment.....	14
4.8 Armrest Adjustment.....	15
4.9 Footplate Height Adjustment.....	16
4.10 Footrest.....	16
4.11 Pelvic Belt.....	17



4.12 Manual Brake.....	18
4.13 Anti-Tippers (Optional).....	19
4.14 Transferring In.....	20
4.15 Transferring Out.....	20
4.16 Tilting.....	22
4.17 Going Down Kerbs.....	22
4.18 Going Up Kerbs.....	23
4.19 Going Up or Down Steps/Stairs.....	24
4.20 General Use.....	24
4.21 Storage.....	26
5. INSPECTION AND MAINTENANCE.....	26
5.1 Daily Check.....	26
5.2 Regular Maintenance Record.....	27
5.3 Adjustment Manual.....	30
6. ACCESSORIES.....	36
7. TROUBLESHOOTING.....	37
8. SPECIFICATIONS.....	38
9. CLEANING & RECYCLING.....	40
9.1 Cleaning.....	40
9.2 Recycling.....	40
10. WARRANTY.....	41
10.1 Serial Number.....	41
10.2 Warranty Policy.....	41

---

# 1. PREFACE



1.1 Please read this owner's manual carefully before using the wheelchair.

Any improper use of the wheelchair may result in harm or injury.

1.2 This owner's manual includes operation, unfolding/ folding instructions and how to prevent possible accidents for the aspects of the wheelchair.

1.3 This owner's manual is written for KARMA wheelchair: Flexx Series.

1.4 The symbols used in this manual are explained below. Pay special attention to the parts marked with these symbols.

 <b>WARNING:</b>	Improper use could lead the user to severe injury or death.
 <b>CAUTION:</b>	Improper use could lead the user to severe injury and/or damage to your wheelchair.
 <b>SUGGESTION:</b>	Follow these instructions to keep the wheelchair in good condition.

1.5 This manual includes the repair and maintenance chart as well as the warranty.

1.6 If someone else uses the wheelchair, make sure that you give him or her this owner's manual for his or her reference.

1.7 As designs change, some illustrations and pictures in this manual may not correspond to the wheelchair that you purchased. We reserve the right to make design modifications without further notice.

## 2. SAFETY

### 2.1 Before Using

The user and attendant must be familiar with the operation of the wheelchair before using. Pedestrian traffic rules apply to the wheelchair. Please be safe.

### 2.2 While Moving

Please always keep these following safety guidelines in mind.

#### 2.2.1 Doorways

The safest way to operate the wheelchair is on level floors that are free of

---

obstacles. If possible, always use a ramp to enter or exit a facility. Keeping your hands on the push rims will allow you to maintain the maximum

balance. DON'T try to force yourself over an obstacle and use the sides of a doorway to pull yourself through a passageway.

## 2.2.2 Leaning and Standing

DO NOT lean over the side or stand on the wheelchair since such an action may cause you to lose balance and fall. (See Figures 2.1 and 2.2)

## 2.2.3 Negotiating Inclines

2.2.3.1. Never turn on a hill due to the danger of tipping over.

2.2.3.2. When an attendant is pushing the wheelchair straight up a slope, if the user needs to go down midway on the slope, walk backwards until the user is on level ground. (See Figures 2.3 and 2.4)



Figure 2.1



Figure 2.2



Figure 2.3



Figure 2.4

2.2.3.3. Do not drive on 7 degrees of incline to avoid danger. When negotiating inclines, don't propel up to 5 degrees of inclines diagonally.

2.2.3.4. Avoid stopping on an incline, it can potentially cause you to lose control of the wheelchair.

2.2.3.5 Do not use the brakes to slow down or stop the wheelchair, this could cause it to stop suddenly and make the user lose control or fall out of the wheelchair.

2.2.3.6 Whenever possible, utilize help from an assistant/attendant while negotiating inclines.



### CAUTION:

- ⊖ Although the product has met ISO 7176-1 requirements, we still recommend you not to drive on any slope (in any direction) greater than 7 degrees.
- ⊖ If your daily activities require crossing <sup>3</sup>slopes, we suggest you purchase and install anti-tippers to increase the stability of the wheelchair.

## 2.2.4 Kerbs

2.2.4.1. Whenever possible, get help from an assistant/attendant. If you have assistance, make sure that your chair is equipped with push handle.

2.2.4.2. DO avoid huge impacts when descending a kerb. A huge impact could probably damage the wheelchair.

2.2.4.3. Never try to scale or descend a kerb that exceeds a normal height.

2.2.4.4. Always be careful and never move up or down a kerb in reverse without an attendant.

### **WARNING:**

- ⊖ Any improper use of the wheelchair could cause severe injury or death.
- ⊖ For increasing your safety, please make sure that you have realized those guidelines as mentioned previously.
- ⊖ ALWAYS follow The Use of Invalid Carriages on Highways Regulations outdoors and the guidelines written in this owner's manual.

## 2.2.5 Streets

2.2.5.1. Always cross streets with great caution.

Reflective tape on the wheelchair and/or your clothing will make you more visible to drivers.

2.2.5.2. Please comply with traffic safety code.

2.2.5.3. Avoid potholes and rough terrain that might cause the casters to get stuck. (See Figures 2.5)



Figure 2.5

## 2.2.6 Stairs

2.2.6.1. Always use two or more assistants. Tilt the wheelchair to its point of equilibrium. One assistant (at the back) holds the wheelchair up against the first step, gripping the handles firmly to lift. The second assistant, holding firmly a fixed part of the front frame, lifts the wheelchair above the stairs and holds it while the first attendant places one foot on the following step and repeat the operation. ( See Figures 2.6~2.7)

---

2.2.6.2. Never go down steps forwards.

2.2.6.3. Never use an escalator for transport; use an elevator.

---



Figure 2.6

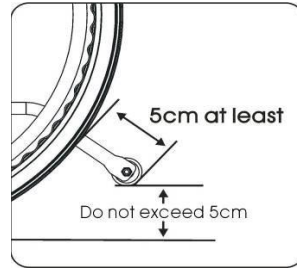

Figure 2.7

## 2.3 General

2.3.1 Always make sure BOTH brakes are applied before getting in or out of the wheelchair.

2.3.2 Never stand on the footplates when getting in or out of the wheelchair

2.3.3 Never carry more than one passenger. KARMA wheelchairs are limited to one user.

2.3.4 Use caution to assure your clothing doesn't get tangled with the wheels.

## 2.4 Upholstery

2.4.1 When cleaning the upholstery, use warm water and a mild soap.

2.4.2 Upholstery cleaner/foam can also be used, but avoid other cleaning solvents.

2.4.3 Do stay far away from any flame because it might injure the user and damage the wheelchair

## 2.5 Anti-Tippers

Please strongly consider purchasing anti-tippers and always use them to avoid personal injury. The distance between the end of each anti-tipper and the rear wheel is at least 5 cm; the distance to the ground is no more than 5 cm.

## 2.6 Maximum User Weight Limit

2.6.1 The maximum user weight limit for Flexx Series is 130 kg. For detail information, refer to Section 8. SPECIFICATIONS.

2.6.2 Please note that loading exceeding maximum capacity can damage your wheelchair and cause malfunctions, which leads to a safety hazard.

---

The warranty does not cover damage caused by improper operation of the wheelchair.



---

## 2.7 Avoid General Misuse

Please note that our "Owner's Manual" contains a number of cautions -- any vehicle can cause injury if misused -- use within our guidelines and with reasonable care and your safety will be increased. Your wheelchair will give years of safe use if used sensibly and carefully. Be aware that careless use endangers your own safety as well as that of others. ALWAYS follow the Highway Code when outdoors and the guidelines written in this manual.

## 2.8 Labeling

Please carefully read all the labeling on the wheelchair before driving it. Do not remove them. Protect them for future reference.



**1**

<b>karma</b>		CE
<b>Karma Mobility Ltd.</b>		
EC	REP	
Unit 6, Target Park, Shawbank Road, Redditch B98 8YN U.K. Tel :0845-630-3436 Fax :0845-630-3736		
<b>Karma Medical Products Co., Ltd.</b>		i
No. 2363, Sec. 2, University Rd., Min-Hsiung Shiang, Chia-Yi Hsien, Taiwan R.O.C.		
WARNING! USE ONLY ON STABLE SURFACES		
<b>MAXIMUM USER WEIGHT 130kg(286lbs)</b>		

**2**

**karma** SERIAL NO. M12-1234

**3**

Model:	
Order No.:	
Delivery Date:	
Sewing No.: 1 <input type="checkbox"/> 2 <input type="checkbox"/> 3 <input type="checkbox"/> 4 <input type="checkbox"/> 5 <input type="checkbox"/> 6 <input type="checkbox"/>	
Seat Width	Seat Depth
<input type="checkbox"/> 13	<input type="checkbox"/> 13
<input type="checkbox"/> 14	<input type="checkbox"/> 14
<input type="checkbox"/> 15	<input type="checkbox"/> 15
<input type="checkbox"/> 16	<input type="checkbox"/> 16
<input type="checkbox"/> 17 <input type="checkbox"/> 0	<input type="checkbox"/> 17 <input type="checkbox"/> 0
<input type="checkbox"/> 18 <input type="checkbox"/> 5	<input type="checkbox"/> 18 <input type="checkbox"/> 5
<input type="checkbox"/> 19	<input type="checkbox"/> 19
<input type="checkbox"/> 20	<input type="checkbox"/> 20
<input type="checkbox"/> 21	<input type="checkbox"/> 21
<input type="checkbox"/> 22	<input type="checkbox"/> _____
<input type="checkbox"/> _____	<input type="checkbox"/> _____
<b>karma</b>	Unit: inch

---

## 3. INTENDED USE & PARTS

### 3.1 Intended Use

- 3.1.1 The Flexx Series is a self-propelled or transit wheelchair. That is, it can either be propelled by the user (self-propelled) or by an attendant (transit).
- 3.1.2 The difference between KM-8022 and KM-8522 is that the backrest of KM-8022 is fixed, and that of KM-8522 is foldable.
- 3.1.3 It is designed to be used indoors, and with certain restrictions outdoor.
- 3.1.4 The bright color of key lockers make it easy for the user to operate the following functions without hesitation: swing away the footrests, flip back and adjust the armrest.
- 3.1.5 It is suitable for a single user up to 130 kg in weight. Hand brakes are provided for both rear wheels.
- 3.1.6 It is a highly adjustable wheelchair, and the detachable parts are easy to operate. Please refer to Section 4. OPERATION and Section 5.3 Adjustment Manual for detail instructions of adjustments.
- 3.1.7 Rear wheels with 24" solid tires and ergonomic handrims are provided as standard equipment. It also has an extremely durable aluminum alloy frame with tough accessories and does not deteriorate when exposed to extreme temperature. (neither the user nor the attendant need to touch any metal part in normal use)
- 3.1.8 The front casters are 7" solid tire as standard equipment.
- 3.1.9 When prescribing wheelchairs for use by full or partial amputees. (above or below knee, single or double) or other conditions that affects the user's natural centre of gravity, we suggest contacting your therapist or dealer as well as attaching anti-tippers.
- 3.1.10 Please contact your dealer for the optional accessories of the Flexx series which are planned to be launched shortly.

### 3.2 Flexx Parts Description

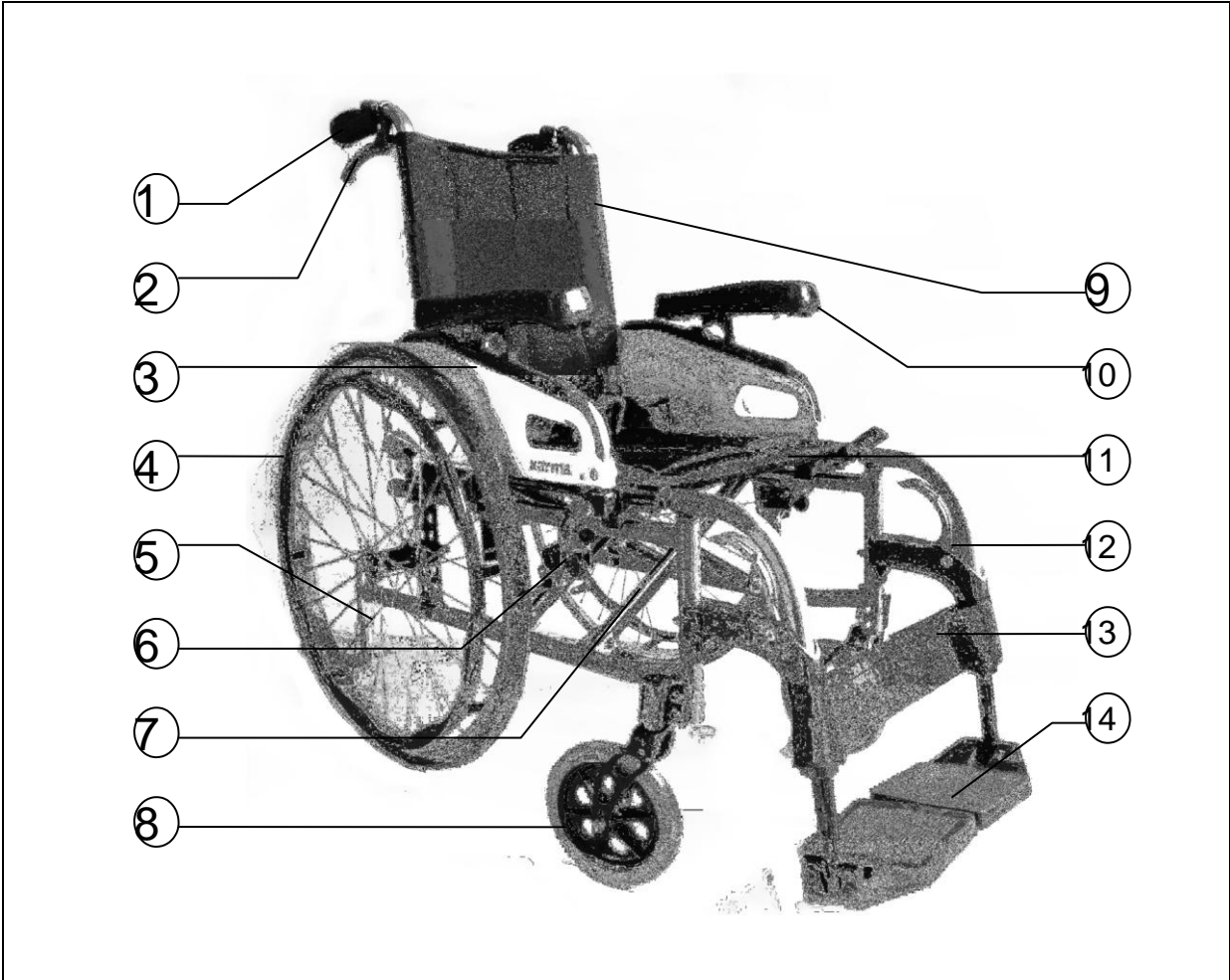

1. Push Handle	8. Caster
2. Attendant Brake (Optional)	9. Backrest Upholstery
3. Side Panel	10. Height Adjustable Armrest
4. Quick Release Rear Wheel	11. Seat
5. Anti-Tipper (Optional)	12. Swing-Away & Detachable Footrest
6. Manual Brake	13. Two-Piece Calf Strap
7. Cross Brace (Cross Bar)	14. Footplate

 CAUTION:

⊖ Standard equipments are subject to change without notice.

---

## 4. OPERATION

### 4.1 Preparing For Use

#### 4.1.1 Unpacking

4.1.1.1 If any part proves defective or missing, please notify your dealer immediately.

4.1.1.2 Please consult this owner's manual for complete instructions on the installation and operation of your Flexx.

#### 4.1.2 Assembly of Swing-Away & Detachable Footrests

Please follow the below instructions for the assembly of Swing-Away & Detachable Footrests.

4.1.2.1 Footrests are packaged in a carton. (See Figure 4.1).

4.1.2.2 The items included are as show in the list below. (See Table 4.1 and Figure 4.2 )

4.1.2.3 Insert the footplate into the footrest. (See Figure 4.3)

4.1.2.4 Adjust the footplate to the appropriate length, and insert the bolt and the nut. (See Figure 4.4 and 4.5)

4.1.2.5 Use the #4 Allen Key wrench provided by KARMA to tighten the bolt and the nut. (See Figure 4.6)



Figure 4.1



Figure 4.2

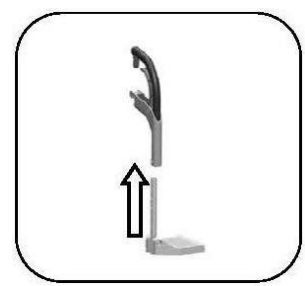

Figure 4.3



Figure 4.4



Figure 4.5



Figure 4.6

Table 4.1 Swing-Away & Detachable Footrest Assembly Part List		
No	Part	Quantity
1	Swing-Away & Detachable Footrest	2
2	Tube-in-Centre Footplate	2
3	M6 Bolt	2
4	M6 Nut	2
5	Calf Strap	2

### 4.1.3 Unfolding

While unfolding the Flexx, follow these instructions as listed below:

4.1.3.1 Stand at the side of the wheelchair as you prefer, hold the armrests and pull outwards. (See Figure 4.7).

4.1.3.2 Put your two hands on the seat pan and push down until the seat is fully lowered, be careful not to get your fingers caught. Make sure the frame is firmly seated in its holder (See Figure 4.8)

4.1.3.3 Install the footrests. (See Figure 4.9)

4.1.3.4 Flip the footplates down. (See Figure 4.10)

4.1.3.5 Fix the calf straps, and attach them. (See Figure 4.11 & 4.12)

4.1.3.6 Place the back and seat cushion on the wheelchair.

4.1.3.7 Ready to use!



Figure 4.7



Figure 4.8



Figure 4.9



---

Figure 4.10

Figure 4.11

Figure 4.12



**CAUTION:**

- ⊖ While completing step 4.1.3.2, never put your fingers around the sides or under the wheelchair as they can be trapped between the seat and the frame. (See the figure at the right.)
- ⊖ The calf straps should be adjusted to the length appropriate for the user's condition.

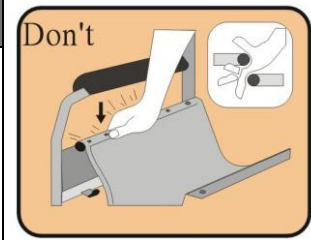

#### 4.1.4 Folding

While folding the Flexx, follow these instructions as listed below:

4.1.4.1 Unfasten the calf strap. (See Figure 4.13)

4.1.4.2 Flip up the footplates. (See Figure 4.14)

4.1.4.3 Pull up the seat by holding the front and the back of the seat. (See Figure 4.15)

4.1.4.4 Folding is now completed. (See Figure 4.16)



Figure 4.13



Figure 4.14



Figure 4.15



Figure 4.16



**CAUTION:**

- ⊖ Be careful not to get your fingers caught when folding the wheelchair.

#### 4.2 Getting Into Your Wheelchair (See figure 4.17)

4.1.1 Push the wheelchair against a wall or a solid piece of furniture.

4.1.2 Apply the brakes.

4.1.3 Flip the footplates up.

4.1.4 The user lowers the body and sits on the wheelchair gently.

4.1.5 Fold down the footplates and position your feet in front of the heel loops.



---

4.1.6 Release the brakes.

---

---

## 4.3 Getting Out of Your Wheelchair (See figure 4.18)

4.3.1 Apply the brakes.

4.3.2 Up move the feet away from the footplates and fold up the footplates.

4.3.3 With one hand on the armrest, the person should bend slightly forward, to bring the body weight to the front of the seat, and then with both feet firmly on the ground and one foot behind the other, push up into the upright position.



Figure 4.17



Figure 4.18

## 4.4 Rear Wheel Disassembly

Quick release rear wheels are optional. If your wheelchair is equipped with quick release rear wheels, please follow these instructions as listed below.

4.4.1 Ensure that the brake is in the unlocked position first.

4.4.2 Support the weight of the chair with one hand by holding the push handle.

4.4.3 Press the hub cover and pull out the rear wheel.

4.4.4 Remove the rear wheel. (See Figure 4.19)

## 4.5 Rear Wheel Assembly

4.5.1 First ensure that the brake is in the OFF position.

4.5.2 Take up the wheel with axle and press the hub cover in the centre of the axle, as above.

4.5.3 This retracts the ball bearings that will allow you to push the axle into the wheel bracket that is located on the lower rear frame of the wheelchair.

4.5.4 When you remove your thumb from the button on the axle, the ball bearings should be visible protruding from the axle at the back of the

---

wheel bracket. This will secure the wheel safely in the frame. (See Figure 4.20)

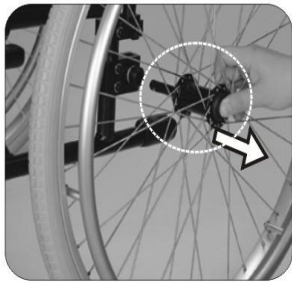

Figure 4.19

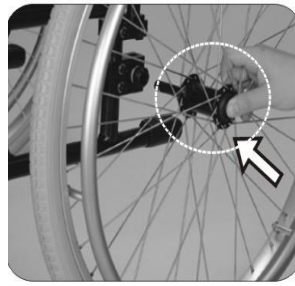

Figure 4.20

 CAUTION:

- ⊖ You must make sure that the axle is fully located in the wheelchair bracket and that the ball bearings are fully open and have positively attached the wheel in the frame.
- ⊖ The rear wheel can be mounted at different positions on the frame to alter the seat height and overall stability of the chair. Changing the wheel position should be carried out by your approved repairer or therapist.
- ⊖ Do keep the axle clean and lubricated with light oil or maintenance spray.
- ⊖ If pneumatic tires are fitted, please maintain them at the correct tire pressure.
- ⊖ When the wheelchair is occupied, DO NOT try to remove the rear wheel even when anti-tippers are equipped.

## 4.6 Backrest Angle Adjustment

To adjust the backrest angle, follow the instruction as listed below and in Section 5.3.4:

4.6.1 Flip back the armrest (if equipped).

4.6.2 Please refer to Section 5.3.4 Backrest Angle

Adjustment. Use the tool provided by KARMA to loosen the bolts and nuts at the both sides of the backrest frame.

4.6.3 Adjust the backrest forward or backward to the position as desired. (See Figure 4.21)

4.6.4 Retighten the bolts and nuts firmly.

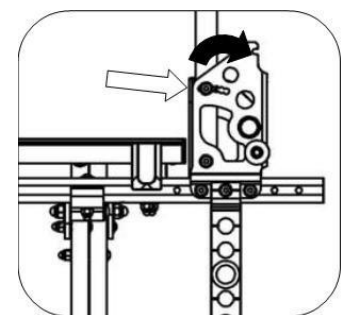

Figure 4.21

 CAUTION:

e The adjustment is in increments of  $4^\circ$  (6 positions), and the range of adjustment is  $20^\circ$  (from  $-4^\circ$  to  $16^\circ$ )



## WARNING:

- ⊖ Anti-tippers **MUST** be equipped, when the backrest angle is set as greater than or equal to eight degrees.

### 4.7 Seat Depth Adjustment

4.7.1 Remove both of the rear wheels and the seat upholstery. Lift the frame up and place it gently on a leveled table or place.

4.7.2 Use the tool provided by KARMA to loosen the bolts on the axle plate of quick release rear wheel. (See Figure 4.22)

4.7.3 Move the fixing plate of backrest tube and the axle plate of quick release rear wheel backward. (The length of adjustment depends on the accessory equipped. It can be 1" or 2" long).

4.7.4 Insert the optional extension tubes. (See Figure 4.23)

4.7.5 Tighten the screws to fix the extension tubes. (See Figure 4.24)

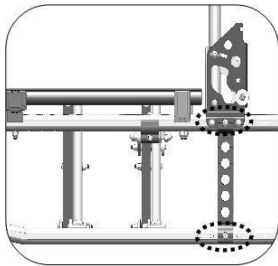

Figure 4.22

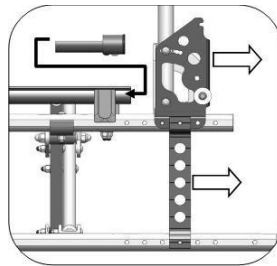

Figure 4.23

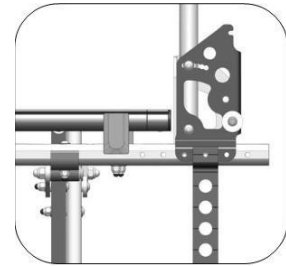

Figure 4.24

4.7.6 Position back the axle plate of quick release rear wheel, and re-tighten the bolts.

4.7.7 Re-assemble the rear wheels.

4.7.8 Add the seat depth extension strip at the front of the seat, and place back the seat upholstery. (See Figure 4.25)

4.7.9 Cover the seat depth extension strip with the extended part of the seat upholstery. (See Figure 4.26)





Figure 4.25

Figure 4.26

 CAUTION:

- ⊖ The adjustment is in increments of one inch or two inches. The length of adjustment depends on the accessory equipped.
- ⊖ Changing the seat depth should be carried out by authorized dealer or qualified therapist.
- ⊖ As the seat depth changes, the manual brakes and the front support also moves. Adjust the caster bracket to make it vertical to the floor.

 WARNING:

- ⊖ For your safety, when the seat depth is set as 18", please note the wheelchair CAN NOT be equipped with 20" rear wheels.

### 4.8 Armrest Adjustment (if equipped)

The available armrest is flip-back height-adjustable armrest.

#### 4.8.1 To flip-back the armrest:

Press the key locker of and lift the armrest up to flip it back. (See Figure 4.27 and 4.28)

#### 4.8.2 To adjust the height of the armrest.

4.8.2.1 Gently press the spring lock at the armrest and lift it up. (See Figure 4.29 and 4.30)

4.8.2.2 Adjust the height as desired.



Figure 4.27



Figure 4.28



Figure 4.29



Figure 4.30

 CAUTION:



- 
- ⊖ The adjustment is in increments of 2 cm (5 positions), and the range of adjustment is 8 cm.
  - ⊖ Before the user uses the armrest to release pressure or transfer, please make sure that the armrest height is secured in the effective range.

- ⊖ When the attendant is moving the chair when it is occupied, lower the armrest to the lowest point.
- ⊖ Do not sit on the armrest in any circumstances.

## 4.9 Footplate Height Adjustment

To adjust the footplate height, follow the instruction as listed below:

4.9.1 Use the tool provided by KARMA to loosen the bolts at the bottom part of the footrest. (See Figure 4.31)

4.9.2 Adjust the height till the user feel comfortable or the user's thighs are parallel to the ground. Retighten the bolts.



Figure 4.31



Figure 4.32



Figure 4.33



Figure 4.34

### ⚠ CAUTION:

- ⊖ The adjustment is in increments of 2.5 cm (5 positions), and the range of adjustment is 10 cm.
- ⊖ Make sure that the footplate height is adjusted properly according to the user's calf length to reduce pressure on the body. (See Figure 4.33 and 4.34)
- ⊖ The distance between the footplates to the floor must be more than 3 cm from the floor. (See Figure 4.32)

## 4.10 Footrest

Footrests can be swung away and be detached, which makes transferring out easier. Please follow below instructions to swing away and detach them.

4.10.1 Unfasten the calf straps. (See Figure 4.35)

4.10.2 Flip up the footplates. (See Figure 4.36)

4.10.3 Hold the release lever and swing the footrest to the side. Depending on the environment the user is in, you can swing it inward or outward. (See Figure 4.37)

---

4.10.4 When the footrest is swung to the side, it can be detached by lifting it

---

up. (See Figure 4.38)



Figure 4.35



Figure 4.36



Figure 4.37



Figure 4.38

## 4.11 Pelvic belt

Please follow the instructions below to use the pelvic belt for your safety.

### 4.11.1 How to Operate It

4.11.1.1 When you sit on the wheelchair, fasten the pelvic belt. (See Figure 4.39)

4.11.1.2 Adjust the belt and make it fit your body for comfort and safety.

4.11.1.3 The most comfortable way of using the pelvic belt is to keep it as 45 degrees. (Figure 4.40)

4.11.1.4 When you don't use it, please fasten the belt to avoid the belt dropping into the rear wheels during motion.



Figure 4.39

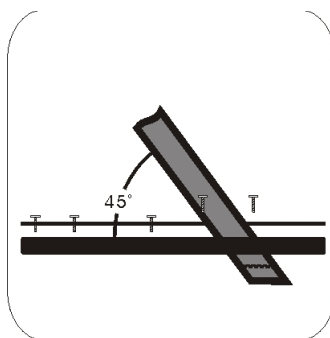

Figure 4.40

### SUGGESTION:

- ⊖ Please kindly be advised that the pelvic belt should be fitted tightly around the user's pelvis and be tightened until you can just get one finger through between the pelvic belt and the user. Kindly check the pelvic belt position is fitted to the place as we recommend. If it is not able to be this way, please consult your supplier.

## 4.11.2 Pelvic belt Adjustment

4.11.2.1 Make sure that the total length of the pelvic belt is sufficient.

4.11.2.2 Adjust the length of the pelvic belt through the buckle of both ends.

(Figure 4.41)

4.11.2.3 Pull the two parts of belt tight. (Figure 4.42)

4.11.2.4 Push the buckle of both ends to the plastic clip so that the pelvic belt will not slip out of the position. (Figure 4.43)



Figure 4.41

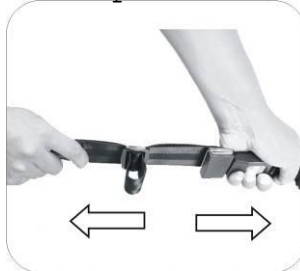

Figure 4.42



Figure 4.43

## 4.11.3 Maintenance

The pelvic belt is made from 100% polyester fibers and the clasp is made from plastic. It does not require any maintenance but should be inspected every month to ensure that the edges are not frayed and weekly to make sure that it correctly fits the user.



### CAUTION:

⊖ **Maintenance:** There is no specific maintenance for the pelvic belt; however, please check if the edge of the pelvic belt is worn or torn before you use it. Meanwhile, please adjust the pelvic belt properly to fit the user. If the pelvic belt is damaged, please replace a new one immediately.

## 4.12 Manual Brake

This wheelchair is equipped with two manual brakes.

4.12.1 They are applied directly against the tires. Push the handle of the manual brake forward to engage and pull the handle of to release.

4.12.2 Braking could be less efficient due to:

4.12.2.1 Worn tire tread.

---

4. 12.2.2 Low tire pressure. (if equipped with pneumatic tires)

---

4. 12.2.3 Wet tires

4. 12.2.4 Improper wheel locks adjustment.

4.12.3 The manual brakes are not designed to be used for a moving wheelchair.

4.12.4 Always use the handrims for braking when you are in a moving wheelchair. Make sure that the interval between the tires and the brakes complies with the given specifications. (See Figure 4.44)

4.12.5 To adjust the interval between the tires and the brakes, first loosen the bolts and set the appropriate gap. Then re-tighten the bolts. (See Figure 4.45)

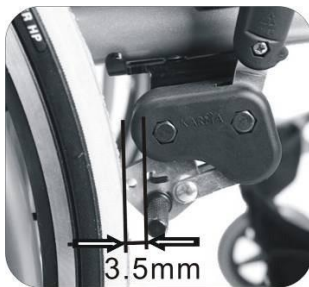

Figure 4.44

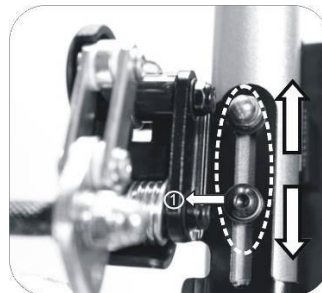

Figure 4.45

 CAUTION:

ⓘ After each adjustment of the rear wheels, check the manual brake gap and re-adjust if necessary.

### 4.13 Anti-Tippers (Optional)

The main purpose of anti-tippers is to prevent the user from tipping over backward.

4.13.1 When you install the anti-tippers, if the anti-tippers are adjustable, please make sure the distance between the end of each anti-tipper and the rear wheel is at least 5cm; the distance to the floor does not exceed 5cm. (See Figure 4.46)

4.13.2 To avoid the attendant from stumbling when pushing it forwards/backwards, be sure to put the anti-tippers away by treading them in

---

clockwise/ counterclockwise directions. (See Figure 4.47 and Figure 4.48)



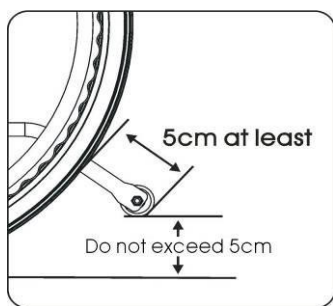

Figure 4.46



Figure 4.47



Figure 4.48

**CAUTION:**

- ⊖ If the anti-tippers are not fitted, or have been fitted incorrectly, there is a risk of tipping over and of injury

**WARNING:**

- ⊖ When the axle has been adjusted, the wheelchair must be evaluated by a qualified therapist. The position of the anti-tippers must be adjusted to guarantee your safety.
- ⊖ Anti-tippers **MUST** be equipped, when the backrest angle is set as greater than or equal to eight degrees.

## 4.14 Transferring In

4.14.1 Engage both hand brakes.

4.14.2 Turn the footplates up and swing them to the side.

4.14.3 Lower the user into the seat, allowing them to use the armrests for support.

4.14.4 Turn the footplates back down, so that the user can place his feet on them.

**CAUTION:**

- ⊖ Always ensure that the front casters are in line with the rear wheels and pointing forwards and that the back of the chair is secure either against a wall or firmly held by an attendant.

## 4.15 Transferring Out

4.15.1 Sideways transfer.

This approach is appropriate for users with sufficient torso strength.

---

4.15.1.1 Flip back your armrest, and make sure that the chair is near your final destination.

4. 15.1.2 Prop up your body and move sideward slowly, using transfer board. Be careful not to hit the brake or other components of wheelchair.

#### 4.15.2 Front transfer

This approach is appropriate for users who are more or less able to stand up and have strong upper body.

4.15.2.1 Make sure that the place where you're moving to is as close to you as possible.

4. 15.2.2 Move the wheelchair backwards so that the casters are pointing forwards and are in line with the rear wheels.

4.15.2.3 Ensure that, where possible, the rear of the chair is against a wall or, if not, it must be firmly held by an attendant.

4. 15.2.4 Engage both hand brakes.

4.15.2.5 Turn the footplates up and swing them to the side.

4. 15.2.6 Slide forwards on the seat. Place one foot firmly on the ground with the knee at a right angle and the other foot slightly apart and further back.

4. 15.2.7 Place your hands on the front of the armrests and moving your weight forward, bring your head and shoulders up over your knees as you push yourself up.



#### CAUTION:

- ⊖ Never stand on the footplates when getting into (or out of) the chair. (See Figure 4.49)
- ⊖ When getting in and out of the wheelchair please use the hand brakes. The hand brake is the lever at the side of the wheelchair.
- ⊖ Make sure that the brakes are applied to prevent the chair from sliding away. Also see that the footplates are flipped up for ease of entering or exiting. (See Figure 4.50)
- ⊖ Please ensure that neither the tread on your tires nor the brake block has become too worn. If pneumatic tires are fitted, please maintain at the recommended tire pressure for the same reason.
- ⊖ Please ensure that occupant's fingers do not get caught in the brake.



Figure 4.49



Figure 4.50



Figure 4.51

## 4.16 Tilting

For the user's safety, tilting must be performed by an attendant.

4.16.1 Make sure both the user's feet are on the footplates and will not slip off. Make sure the handgrips are secure and cannot slip off.

4.16.2 Release both brakes.

4.16.3 Grasp both push handles firmly.

4.16.4 Tell the person in the wheelchair that you are about to tilt the wheelchair backwards.

4.16.5 Pull back with both hands and push down and forwards with the foot. This will bring the wheelchair onto the back wheels. (See Figure 4.51)



### CAUTION:

- ⊖ When a wheelchair is tilted to about 25 degrees it will balance on the rear wheels and be easy to hold. If it is tilted further back it will be difficult to hold and the person in the wheelchair will feel unsafe.
- ⊖ Lower the wheelchair with your back straight, keep your foot on the anti-tipper and lower the wheelchair slowly forwards softly to the ground.

## 4.17 Going Down Kerbs

Please note: It is always better to avoid kerbs where possible by using ramped kerbs or slopes and this operation is best attempted with the aid of an attendant.

4.17.1 Going Down Kerbs Forwards with an Attendant.

 **CAUTION:**

- ⊖ This is the more difficult method and can jar the user but allows a better view of traffic.
- ⊖ Be careful that the anti-tippers do not get caught on the kerb causing the user to fall.
- ⊖ **NEVER ALLOW THE WHEELCHAIR TO TIP FORWARDS WHEN GOING DOWN A KERB.**

4.17.1.1 Position the wheelchair so that the front casters are near the edge of the kerb and make sure that the road is clear.

4. 17.1.2 Move the wheelchair slowly and carefully forwards while tilting it back slightly. Be ready to take the weight when the rear wheels cross the kerb edge. Ensure that both rear wheels touch the ground at the same time to avoid tipping the wheelchair.

4. 17.1.3 Gently lower the front casters, and **AVOID JARRING THE USER.**

4.17.2 Going Down Kerbs Backwards with an Attendant.

 **CAUTION:**

- ⊖ **This is the easier and smoother method BUT it requires the attendant to step backwards into the road.**

4.17.2.1 Back the wheelchair to the kerb edge and be careful that the back wheels are equally near the edge.

4. 17.2.2 Grasping the push handles, gently lower the rear wheels onto the road. Be prepared to control the weight as it descends and ensure that the back wheels touch ground at the same time.

4. 17.2.3 Tilt the wheelchair back slightly and pull the tilted wheelchair far enough into the road so that the casters and footrests can be lowered clear of the kerb.

## 4.18 Going Up Kerbs

Please note: This operation is best attempted with the aid of an attendant and the best method is to go up kerbs forwards as this maintains the

---

direction of travel and is physically less demanding for the attendant.

---

#### 4.18.1 Going Up Kerbs Forwards with an Attendant

4.18.1.1 As the footrests nearly touch the kerb tilt the wheelchair. The wheelchair should be tilted just high enough to allow the front casters to roll smoothly onto the pavement.

4.18.1.2 Push the wheelchair forward until the rear wheels are touching the kerb. Then, continuing the movement, lift at the push handles while moving the wheelchair forwards.

#### 4.18.2 Going Up Kerbs Backwards With an Attendant

Please note: for safety's sake we do not recommend using this method

### 4.19 Going Up or Down Steps/Stairs

4.19.1 Please note: avoid flights of steps particularly if no extra help is available. Use ramps or lifts wherever possible.

4.19.2 Two attendants are necessary, each capable of carrying at least half of the combined weight of the person and the wheelchair.

4.19.3 Each helper should bend at the knees and grip the main frame: with the front attendant's hands just under the front of the seat, with the back attendant's hands holding the frame just under the push handles.



#### **CAUTION:**

- ⊖ **Never hold on to movable or detachable parts.**
- ⊖ **ALL LIFTING SHOULD BE DONE WITH A STRAIGHT BACK.**
- ⊖ **Straighten legs to lift the wheelchair. Carefully carry it up or down steps; be aware of how you place your feet -- do not cross them and trip yourself up.**

### 4.20 General Use

In conditions of normal use in attendant pushing or self propelling, please follow the instructions below.

4.20.1 Ensure that the brakes are always locked when the chair is not being pushed. (See Figure 4.52)

4.20.2 Always make sure that both feet are safely on the footplates and that

---

clothing is safely tucked out of the way and cannot get caught in the wheels. (See Figure 4.53)

4.20.3 Always use both hands on the push handles to control the chair. (See Figure 4.54)

4.20.4 Always avoid steep or uneven surfaces because the chair may tip over. (See Figure 4.55)

4.20.5 Always avoid soft surfaces because the casters may get bogged down. (See Figure 4.56)

4.20.6 Always be careful not to go too fast or turn too quickly and try to maintain a smooth and steady ride.

4.20.7 Before crossing the road, please stop completely and look both ways.

4.20.8 Cross tracks or ruts at right angles to avoid your casters getting stuck.

4.20.9 Do not drive at full speed over the railroad tracks.

4.20.10 Please keep your hands and arms inside the wheelchair when going through doorways.

4.20.11 Note to the attendant- PLEASE keep in contact with the person in the chair. If you stop to look in shop windows or talk to people, remember to turn the chair so that the person in the chair does not have to turn.

 **WARNING:**

**NEVER lock the brakes too quickly as this may tip the user out of the wheelchair.**



Figure 4.52



Figure 4.53



Figure 4.54





Figure 4.55



Figure 4.56

## 4.21 Storage

Make sure that the wheelchair is fully folded when it is in storage.

### SUGGESTION:

- ⊖ Please store the wheelchair in a location where it is out of direct sunlight, rain and dew. For more details, consult your KARMA dealer.

### WARNING:

- ⊖ Don't put anything on the wheelchair while it is in storage. Storing goods on a folded wheelchair will cause damage and is not covered under warranty. (See the figure at the right.)



## 5. INSPECTION AND MAINTENANCE

### 5.1 Daily Check

- 5.1.1 Check the following items before travelling. If you find anything abnormal, visit your KARMA wheelchair dealer for further inspection before using it.
- 5.1.2 Examine the brakes and check for any wear, damage and misalignment. Replacing or adjusting the brakes should be carried out by your approved technician.
- 5.1.3 Check that the handgrips are not damaged and are securely bonded to the push handles.
- 5.1.4 Check that the anti-tippers are not damaged and are securely attached.

---

5.1.5 Check that the anti-tippers' wheels and frame are not damaged and are

securely mounted.

5.1.6 Before using the wheelchair, make sure all nuts and bolts are tight.

Check all parts for damage or wear and have a qualified technician replace it if necessary. Check all parts for proper adjustment. Inspect brakes for proper operation.

5.1.7 The wheels and tires should be checked periodically for cracks and wear, and should be replaced by a qualified technician.

5.1.8 A qualified technician can be found at an authorized distributor/dealer.

 **CAUTION:**

ⓔ Visit a KARMA wheelchair dealer for inspection and maintenance if you find anything abnormal.

## 5.2 Regular Maintenance Record

5.2.1 In order to make sure your wheelchair is in good condition, visit your KARMA wheelchair dealer regularly for maintenance and keep records accordingly every six months after purchasing.

5.2.2 A maintenance/service fee may apply.

 **WARNING:**

ⓔ Even if you don't use the vehicle for a long time, the wheelchair should still be maintained regularly. You should clean your wheelchair regularly.

ITEM	WEEKLY	MONTHLY
<b>GENERAL</b>		
ⓔ Wheelchair rolls straight (no excessive drag or pull to one side)		✓
<b>FRAME &amp; CROSS BRACE</b>		
ⓔ Inspect frame structure for small cracks/fissures.		✓
ⓔ Inspect for bent frame or cross bars.		✓
<b>BRAKES</b>		

e DON'T interfere with tires when rolling.		✓
e Pivot points free of wear and looseness.		✓

ITEM	WEEKLY	MONTHLY
e Easy to engage.	v	
e Stop the wheelchair from moving when engaged.	v	
<b>SEAT &amp; BACKREST</b>		
e Inspect for rips or sagging.	v	
e Inspect for any loose or broken hardware, such as the frame and etc.		v
<b>CASTERS</b>		
e Inspect the casters for smooth rotation of the caster wheels and caster assembly.		v
e Inspect the caster for any wear in the bearings/mountings and for tire wear or damage.		v
<b>REAR WHEELS</b>		
e Quick-release axles lock properly; lubricate if necessary (applied to quick-release rear wheel only)	v	
e No excessive side movement or binding when lifted and spun.	v	v
<b>ARMRESTS</b>		
e Inspect the detachable armrest button for effective locking.		v
e Make sure the armrest detaches and flips back properly.		v
<b>FOOTRESTS</b>		
e Inspect the footplate height adjustment bolts are securely tightened.		v
e Inspect the swing-away footrest release lever for effective locking.		v
<b>ANTI-TIPPERS</b>		
e Check anti-tippers are not damaged and are securely attached.		v

ITEM	WEEKLY	MONTHLY
<b>TIRES</b>		
⊖ Inspect for flat spots, cracks and wear.	✓	
⊖ If pneumatic tires, check for proper inflation.	✓	
⊖ Check tire tread depth is more than 1 mm.		✓
⊖ Check tire pressure. Tire pressures are specified on the side of the tire.	✓	
<b>PELVIC BELTS</b>		
⊖ Check pelvic belts are rigidly fixed and have no sharp edges to let the user's skin be tore and bruised.		✓



**CAUTION:**

- ⊖ Never disassemble or modify the wheelchair frame structure. Otherwise, injury or damage may occur. This will void the warranty.
- ⊖ As with any wheelchair, the wheels and tires should be checked periodically for cracks and wear, and should be replaced. Failure to keep tires at the correct pressure will reduce the braking efficiency.

## 5.3 Adjustment Manual

### 5.3.1 Wheelbase Length Adjustment

**Seat Depth = 16"**

Align the axle plate with one of the four adjustment holes. There are four positions possible = (See Figure 5.1)

- (1) Factory Setting is Medium position "C." For better stability, please set it as Passive position "D."
- (2) Active position with better handling is "A" and Standard position is "B."

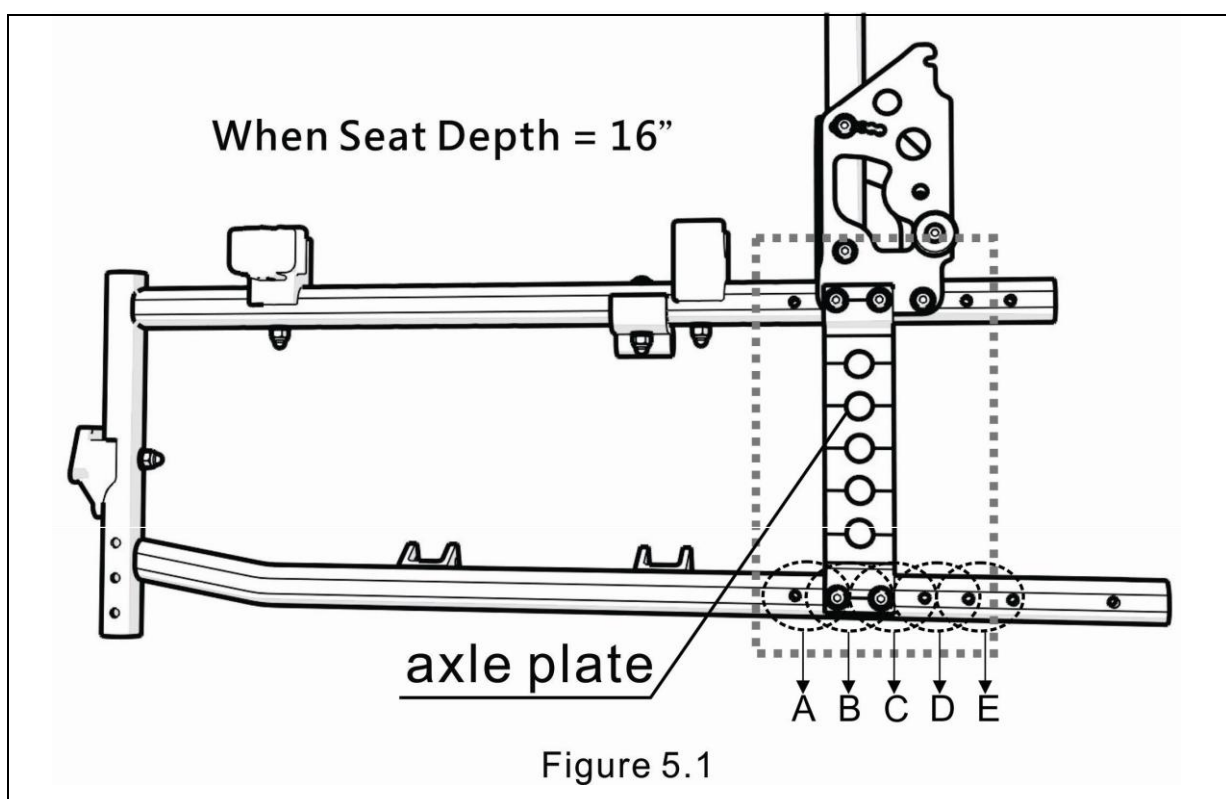

I	Axle plate at <b>A position</b> = Active position.
II	Axle plate at <b>B position</b> = Standard position.
III	Axle plate at <b>C position</b> = Medium position (Factory Setting).
IV	Axle plate at <b>D position</b> = Passive position.



**WARNING:**

- ⓘ When the axle plate is set as Active or Standard position (A or B), anti-tippers **MUST** be equipped to your wheelchair for safety reason.

## Seat Depth = 17"

Align the axle plate with one of the five adjustment holes. There are five positions possible = (See Figure 5.2)

- (1) Factory Setting is Medium position "D." For better stability, please set it as Passive position "E."
- (2) Active position with better handling is "A or B" and Standard position is "C."

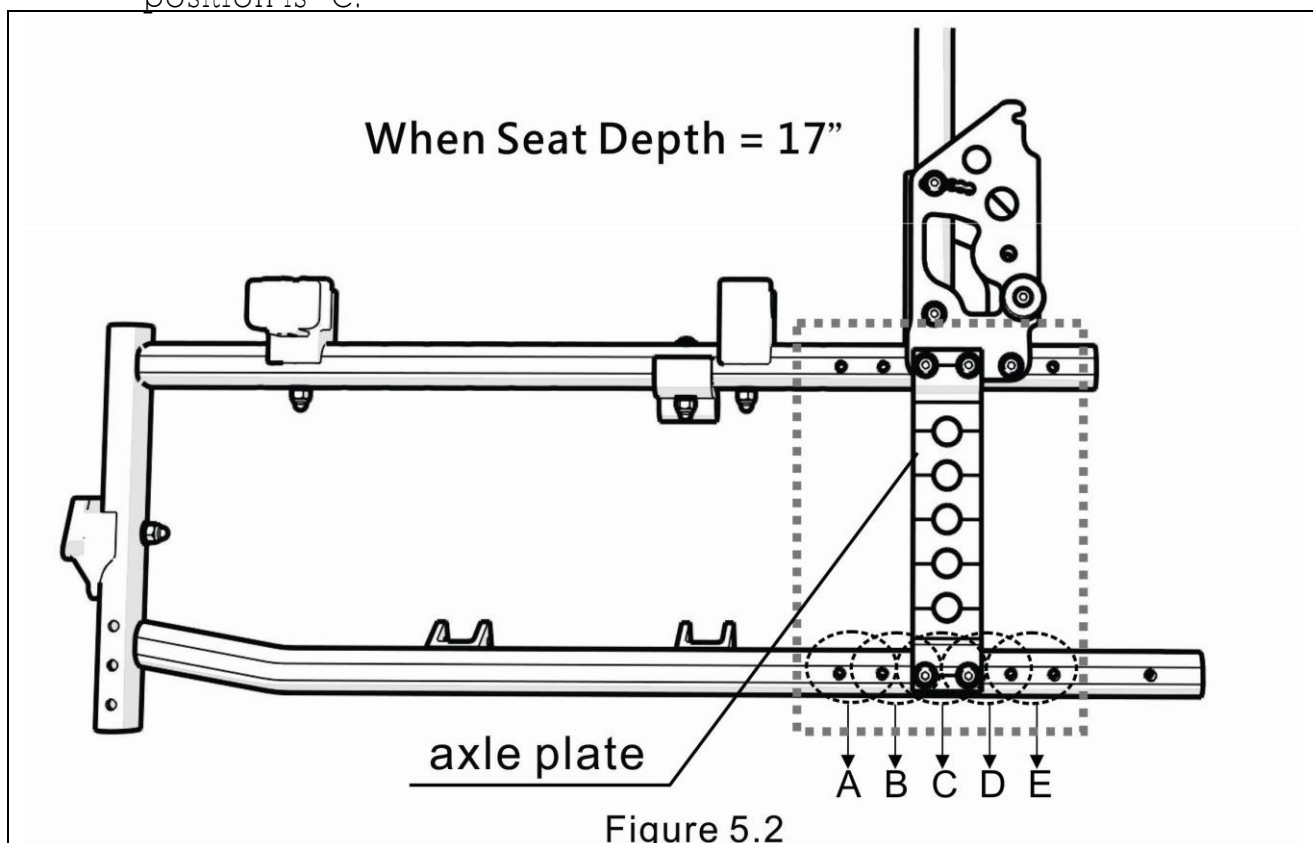

I	Axle plate at A or B position= Active position.
II	Axle plate at C position= Standard position.
III	Axle plate at D position= Medium position (Factory Setting).
IV	Axle plate at E position= Passive position.



### WARNING:

When the axle plate is set as Active or Standard position (A, B or C), anti-tippers MUST be equipped to your wheelchair for safety reason.



## Seat Depth = 18"

Align the axle plate with one of the five adjustment holes. There are five positions possible = (See Figure 5.3)

- (1) Factory Setting is Medium position "E." For better stability, please set it as Passive position "F."
- (2) Active position with better handling is "B or C" and Standard position is "D."

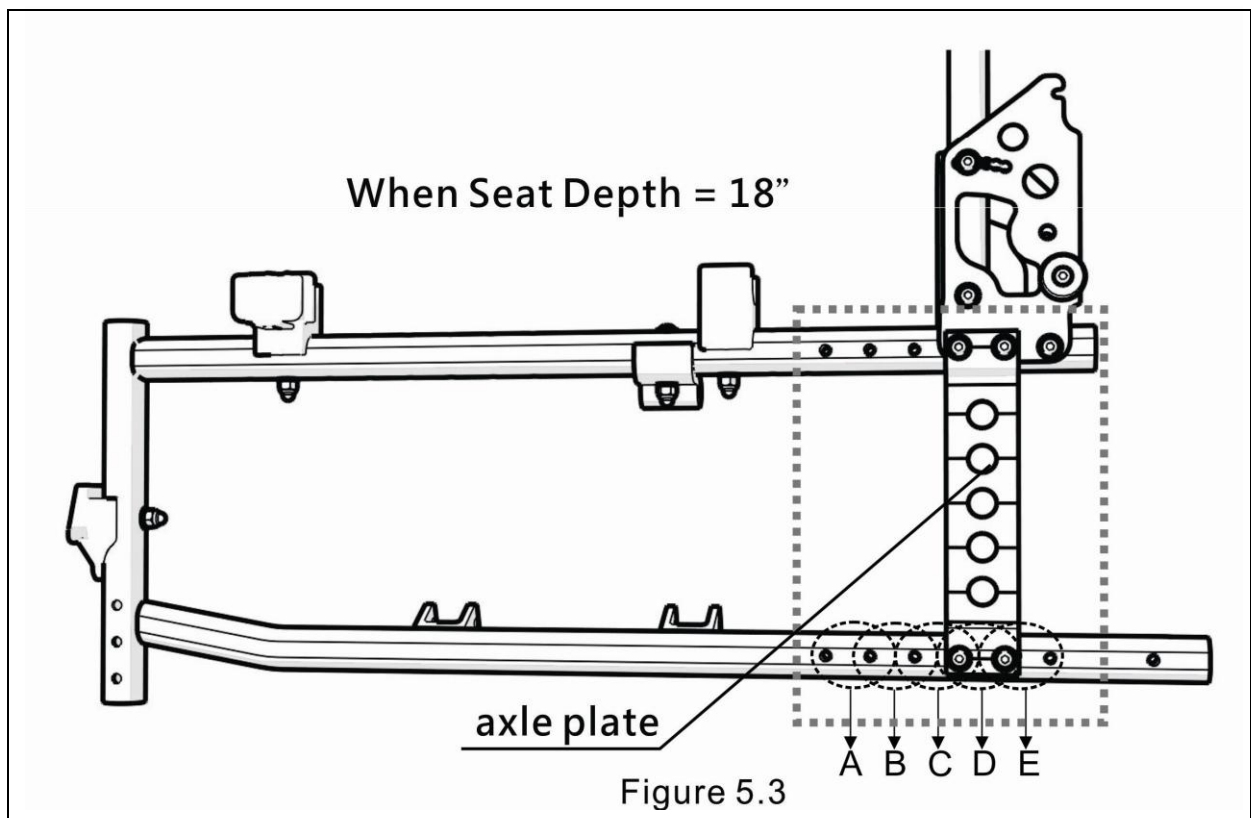

I	Axle plate at <b>B or C position</b> = Active position.
II	Axle plate at <b>D position</b> = Standard position.
III	Axle plate at <b>E position</b> = Medium position (Factory Setting).
IV	Axle plate at <b>F position</b> = Passive position.



### WARNING:

⊕ When the axle plate is set as Active or Standard position (B, C or D), anti-tippers **MUST** be equipped to your wheelchair for safety reason.

### 5.3.2 Seat Height Adjustment for 20", 22" and 24" Rear Wheels

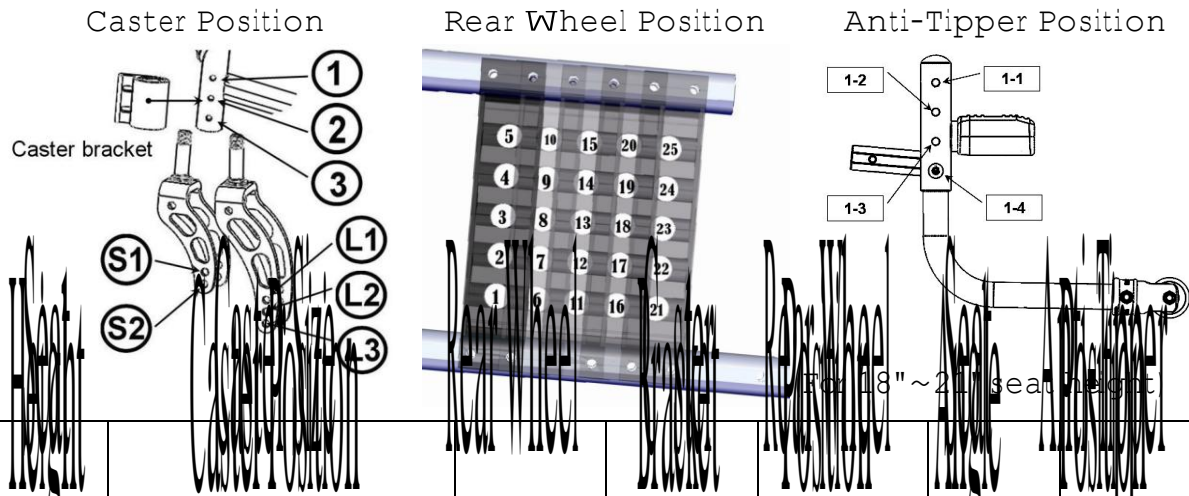

21"	8" L3		24"	2 3	6	7.4	1-4		
	Extra Spacer Required				11	6.9			
					16	6.6			
20"	8" L2	7" L3	24"	2 3	7	5.7	1-3		
	8" L2	7" L3			22"	2 3		12	5.3
	8" L2	7" L3						20"	2 3
	8" L2	7" L3	24"	2 3	6	4.8			
	8" L2	7" L3			22"	2 3		11	4.6
	8" L2	7" L3						20"	2 3
19"	7" L2	6" L3	24"	2 3	6	7.7	1-2		
	7" L2	6" L3			22"	2 3		11	7.3
	7" L2	6" L3						20"	2 3
	7" L2	6" L3	24"	2 3	8	5.7			
	7" L2	6" L3			22"	2 3		13	5.4
	7" L2	6" L3						20"	2 3
7" L2	6" L3	24"	2 3	7	6.2				
7" L2	6" L3			22"	2 3	12	6		
7" L2	6" L3					20"	2 3	17	5.5
7" L2	6" L3	24"	2 3	6	4.3				
7" L2	6" L3			22"	2 3	11	4		
7" L2	6" L3					20"	2 3	16	3.8

Caster Position

Rear Wheel Position

Anti-Tipper Position

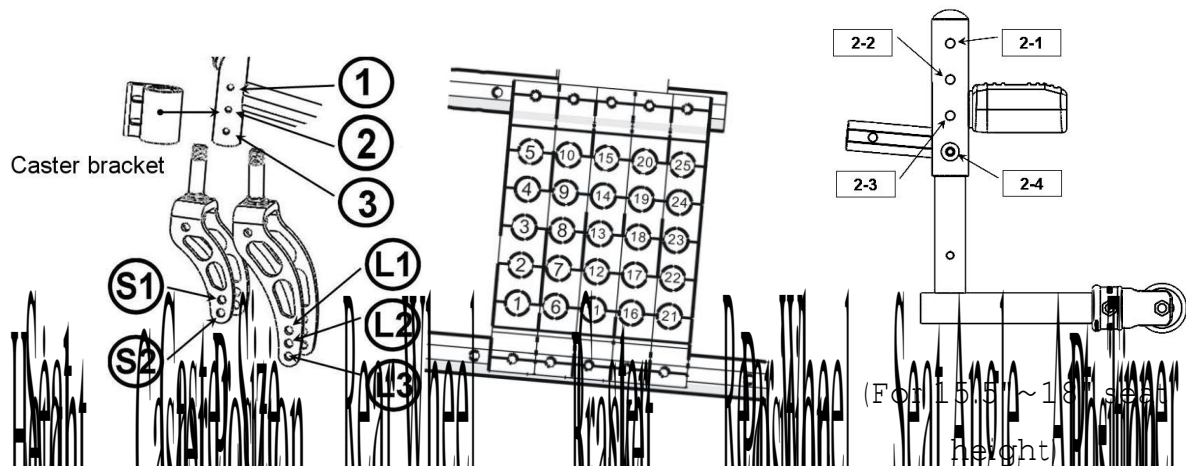

18"	6" L1	5" L2	22"	2 3	8	6.4	1-1	2-4
					13	6.0		
					18	5.7		
	6" L1	5" L2	20"	2 3	7	5.7		
					12	5.4		
					17	5.1		
17"	5" S2	22"	2 3	9	6.0	2-3		
				14	5.7			
				19	5.4			
	5" S2	20"	2 3	8	5.4			
				13	5.1			
				18	4.8			
16"	5" S2	22"	1 2	10	6.4	2-2		
				15	6.1			
				20	5.7			
	5" S2	20"	1 2	9	5.8			
				14	5.5			
				19	5.2			

Caster Position

Rear Wheel Position

Anti-Tipper Position

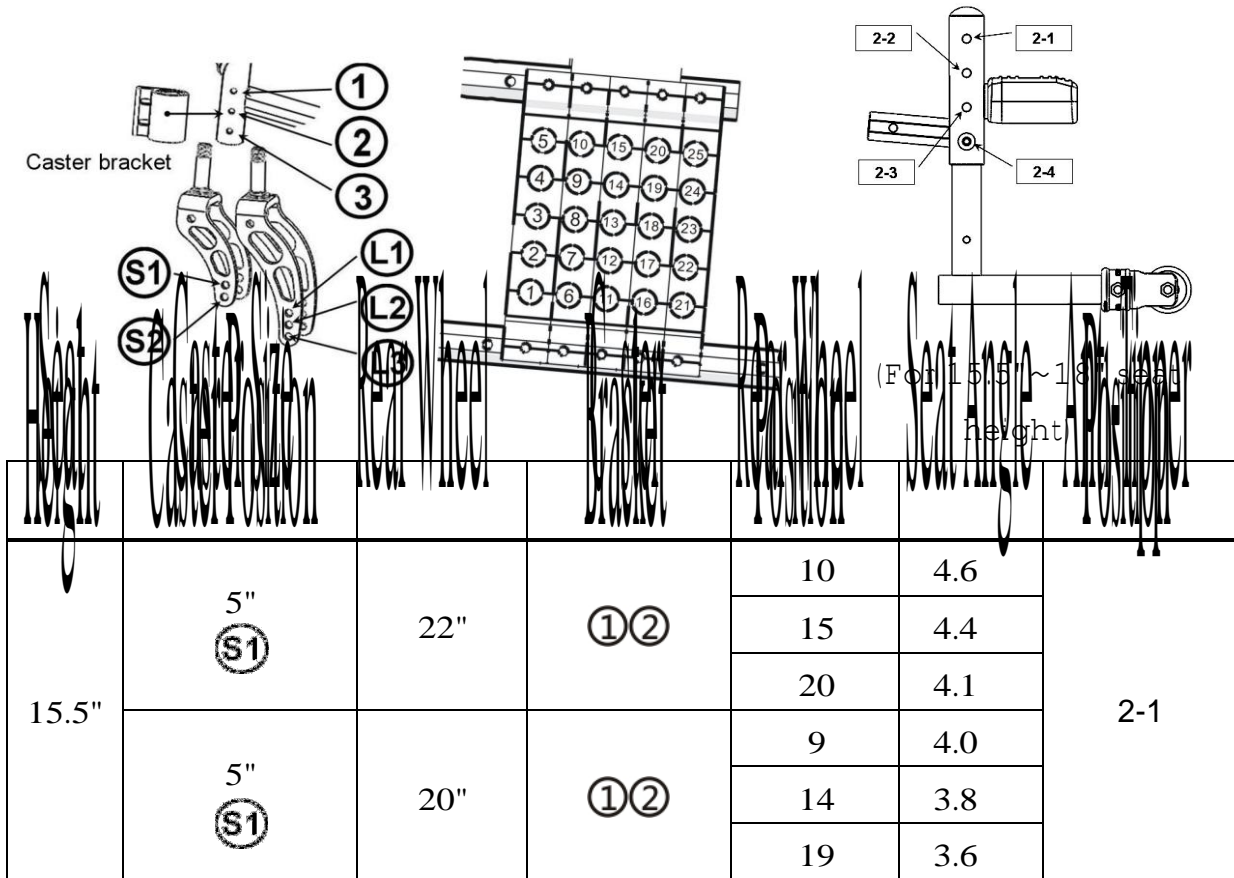

5.3.3 Seat Height Adjustment for 14" Rear Wheels

Caster Position

Rear Wheel Position

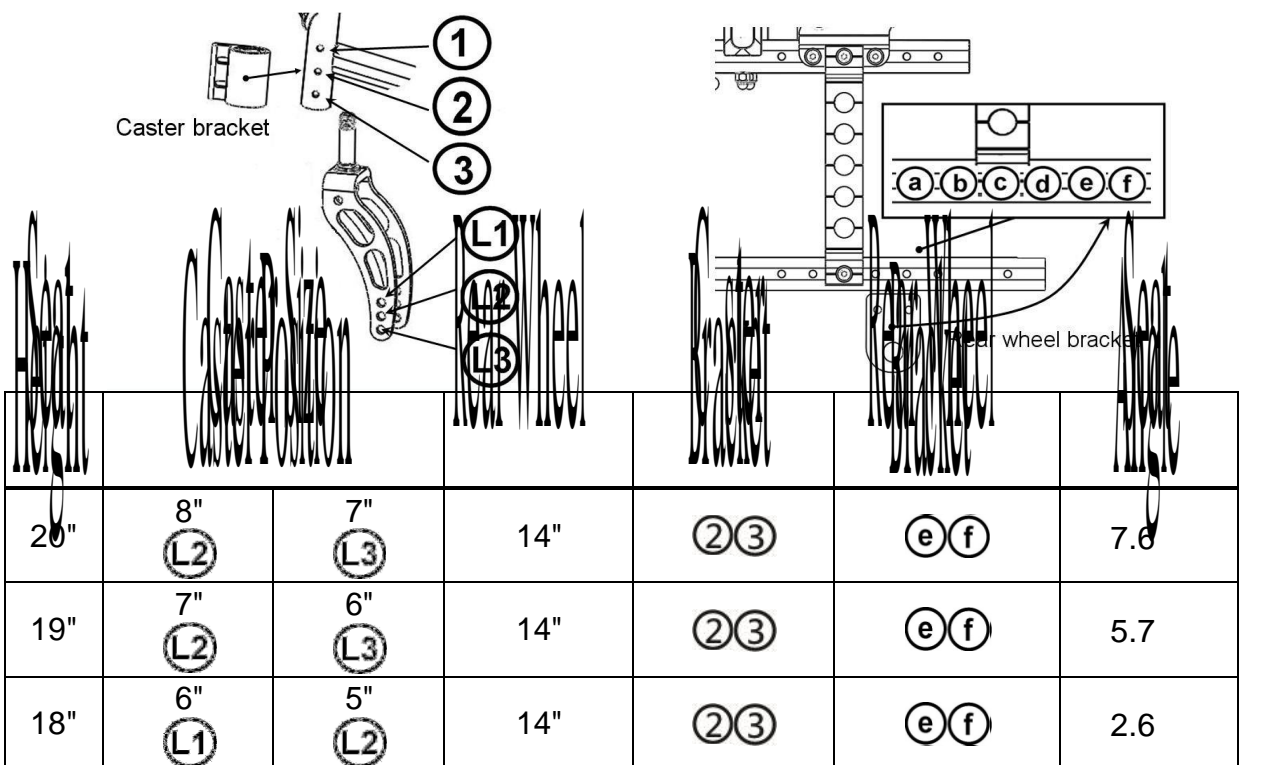

**⊘ WARNING:**

- ⊖ Set the Flexx series at the positions specified in the above sections of 5.3.1, 5.3.2 and 5.3.3.
- ⊖ Anti-tippers **MUST** be equipped to your wheelchair when the axle plate setting is at Active or Standard position mentioned in the Section 5.3.1.
- ⊖ Both rear wheels should be set at the same position.
- ⊖ Any wheel position change should **ONLY** be performed by your local dealers or approved therapists.

5.3.4 Backrest Angle Adjustment.

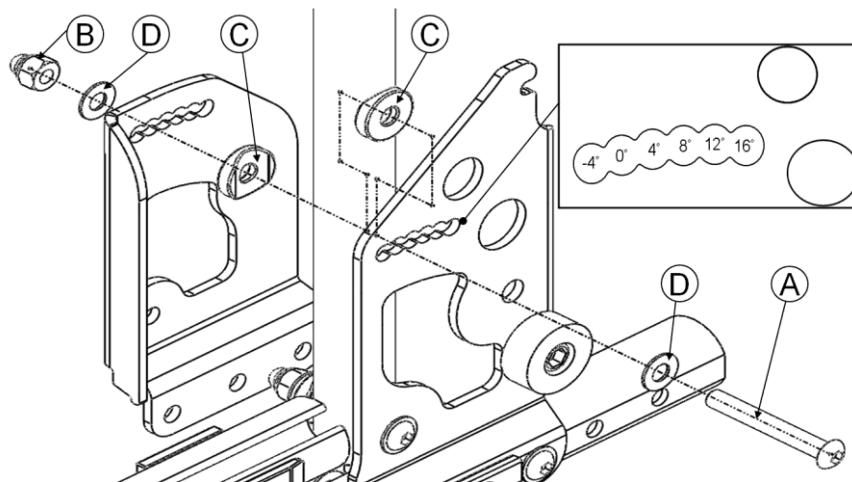

- ⊖ Loosen bolt A and nut B. Remove the arc washers C.
- ⊖ Adjust the backrest tube to the desired position and angle. (from  $-4^{\circ}$  to  $16^{\circ}$ )
- ⊖ Insert bolt A into the new position, and align arc washers C with the angle number specified in the above figure. Tighten bolt A and nut B with washer D.
- ⊖ Repeat the above procedures on the other side of the chair.

**⊘ WARNING:**

- ⊖ Anti-tippers **MUST** be equipped, when the backrest angle is set as greater than or equal to eight degrees.

## 6. ACCESSORIES

Optional accessories are as below, please contact your dealer for the purchase of these items.

6.1 Pneumatic rear wheels.

6.2 Aluminum handrim.

- 6.3 5", 6" and 8" caster.
- 6.4 Attendant brake.
- 6.5 Swing away anti-tipper.
- 6.6 IV pole holder.
- 6.7 Multi-function head support.
- 6.8 Tray for mealtimes, leisure and reading.
- 6.9 Oxygen tank holder.
- 6.10 Hub brake.
- 6.11 Tie-down bracket

 **CAUTION:**

⊖ Attaching accessories may alter the overall stability and centre-of-gravity of the chair. Thus, this should be performed by an authorized dealer/ technician or qualified therapist.

## 7. TROUBLESHOOTING

### Trouble or Problems with Your Wheelchair

You can inspect the following before taking your wheelchair to a KARMA wheelchair dealer.

Problem	Checking Points and Corrective Action
1. Wheelchair Veers Right/Left	<ul style="list-style-type: none"> <li>⊖ Check tires for correct and equal pressure.</li> <li>⊖ Check caster bracket angle.</li> <li>⊖ Check that rear wheels are equally spaced from the seat frame</li> </ul>
2. Sluggish Turn or Performance	<ul style="list-style-type: none"> <li>⊖ Check tires for correct and equal pressure.</li> <li>⊖ Check for loose nuts and bolts.</li> </ul>
3. Caster Flutter/Wobble	<ul style="list-style-type: none"> <li>⊖ Check tires for correct and equal pressure.</li> <li>⊖ Check for loose nuts and bolts.</li> <li>⊖ Check caster bracket angle</li> </ul>
4. Squeaks and Rattles	<ul style="list-style-type: none"> <li>⊖ Check for loose nuts and bolts.</li> </ul>
5. Looseness in Wheelchair	<ul style="list-style-type: none"> <li>⊖ Check for loose nuts and bolts.</li> </ul>

If you cannot solve the problem by yourself, contact your KARMA wheelchair dealer for help.

## 8. SPECIFICATIONS









(±5mm, ±0.5kg)

Model	Flexx (KM-8022 & KM-8522)	
Rear wheel	22" Solid Tire	
Frame Color	Silver Black	
Seat/Backrest Upholstery Cover Color	Black Upholstery/ Black Cushion	
Seat Width/Depth	16" * 16"	
Caster/ Rear Wheel	5" * 22"	
Brakes	Parking Brake	
Overall Length (mm/in)	1078 mm(42.4 in)	
Overall Width (mm/in)	570 mm(22.4 in)	
Overall Height (mm/in)	890 mm(35 in)	
Seat Width (mm/in)	405 mm(16 in)	
Seat Depth (mm/in)	405 mm(16 in)	
Seat Height (mm/in)	430 mm(17 in)	
Backrest Height (mm/in)	430 mm(17 in)	
Armrest Height (mm/in)	200 mm~280 mm(7.8/in~11/in) (Adjustable)	
Calf Length (mm/in)	383 mm~475 mm(15.1/in~18.7/in) (Adjustable)	
Footplates	Tube-in-Centre Flip-Up Footplates	
Overall Collapsed L*W*H (mm/in)	1078 mm *370 mm *890 mm (42.9 in*14.6 in*35 in)	
Seat/Back Angle	6° /-4°~16°	
Total Weight (kg/lb)	Min. 14.5 (±0.5) kg(32.6 lb)	
Maximum User Weight (kg/lb)	130 k(286 lb)	
Packing Size (mm/in)	820 mm*340 mm*950 mm (32.3 in*13.4 in*37.4 in)	

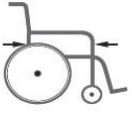
KARMA reserves the right to modify information herein without further notice.

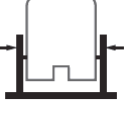
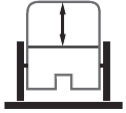
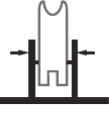
Product specification could be varied according to customer requirements.

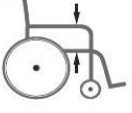
Please be noted that all the above measurements are based on the wheelchair with 16" seat width and 16" seat depth.

Diagram	Item	Min/ Max value	Diagram	Item	Min/ Max value
	Seat Width (mm)	380/ 510		Overall Length (mm)	Max. 1090
	Seat Depth (mm)	410/ 460		Seat Height (mm)	380/ 530
	Overall Width (mm)	600/ 700		Backrest Height (mm)	380/ 530
	Folded Width (mm)	370		Overall Height (mm)	760/ 1060
	Armrest Height (mm)	200/ 280		Overall Weight (kg)	Min. 14.5



**CAUTION**

- e Please don't travel across a slope (in any direction) greater than 7 degrees.
- e DON'T stand on the footplate directly, which the limit weight is 100 kg.

Test Requirement	Static Stability Test Result Flexx Series(KM-8022/8522) (According to ISO 7176-1:1999)
	Min.
Forward	11.2°
Backward	11.2°
Sideways	17°

The degree tolerance is +0, -1 degree.

The test condition:

1. The size of test dummy used is 130 kg(286 lb).
2. The backrest angle is set as 0 degree.





## CAUTION

ⓘ Please do not travel across a slope (in any direction) greater than 7 degrees.

## 9. CLEANING & RECYCLING

### 9.1 Cleaning

In order to lengthen the life of your wheelchair, it is suggested that you clean the wheelchair periodically (if not daily), especially after it is used in the rain or snow. We suggest that you don't use your wheelchair in the rain or snow. If you are travelling and get caught in the rain, we suggest you try to find a shelter while waiting it out. If you can't find any shelter, proceed to your destination.

#### 9.1.1 Frame

9.1.1.1 Wipe with a damp cloth. **DO NOT** use any abrasive material to clean it.

9.1.1.2 Although the frame of your wheelchair is aluminium, some parts, such as screws, nuts and spokes of wheels still get rusted if they are exposed to the humid environment. Always keep it dry and clean.

#### 9.1.2 Upholstery

9.1.2.1 When cleaning the upholstery, use warm water and a mild soap.

9.1.2.2 Upholstery cleaner/foam can also be used. Other cleaning solvents are excluded.

### 9.2 Recycling

A post-consumer recycling plan should follow the Environmental Protection Administration's regulations. The items listed below are for reference only as local laws and regulations may vary.

Material	Part Name	Method
Aluminum-alloy	Frame	Recyclable
Plastic	Modular Components	Recyclable
Paper	Owner's Manual	Recyclable



---

that will accept used goods for charity. Please search the information highway to help less fortunate individuals and protect our planet for future generations. If you do not have access to the world wide web please use your local phone directory, ask for operator assistance or go to your local government centre for more information. Earth Day is every day.

9.2.2 Check with your local recycling centre on where and how to recycle your wheelchair as this information varies from region to region.

## 10. WARRANTY

### 10.1 Serial Number

To ensure after-sale service and warranty, please record and fill in the serial number which can be found on the frame.

<b>Model</b>	
<b>Serial Number</b>	

### 10.2 Warranty Policy

#### 10.2.1 Contents and Duration of Warranty

10.2.1.1 Repair will be provided free of charge if the problems are due to manufacturing or defective components within the warranty period (a repair of this kind will hereafter be called warranty repair).

10.2.1.2 Warranty repairs can be performed by authorized KARMA wheelchair dealers only.

10.2.1.3 KARMA is not responsible for the transportation costs for repair and replacement.

10.2.1.4 Replaced parts will be the property of KARMA.

#### 10.2.2 Items Not Covered by Warranty

10.2.2.1 Irregularities that do not affect function and safety of product.

10.2.2.2 Damage resulting from normal wear and tear.

10.2.2.3 Problems arising due to lack of basic maintenance and self-inspection.

---

10.2.2.4 Damage resulting from use not following operation guidelines.

---

10.2.2.5 Installation or use of parts not manufactured by KARMA.

10.2.2.6 Damage resulting from use in unsuitable environments.

10.2.2.7 Any addition, modification, or alteration not authorized by KARMA.

10.2.2.8 Damage resulting from external factors such as chemicals, oil, debris, etc.

10.2.2.9 Natural disaster.

10.2.3 KARMA is Not Responsible for The Following Costs.

10.2.3.1 Replacement or refill of consumable parts, oil, lubricant.

10.2.3.2 Inspection, adjustment, cleaning, etc.

10.2.3.3 KARMA designated self-inspection costs.

10.2.4 Responsibilities

10.2.4.1 The Responsibilities of the User

10.2.4.1.1 Fully adhere to operation guidelines set forth in this manual.

10.2.4.1.2 Perform self-inspection and basic maintenance.

10.2.4.1.3 Keep a record of self-inspections and basic maintenance.

10.2.4.1.4 Not permit any alteration, addition, or modification or use of parts not manufactured by KARMA.

10.2.4.1.5 Thoroughly read and understand this manual.

10.2.4.2 The Responsibilities of the Dealer

10.2.4.2.1 Follow this manual and educate users about product operation and basic maintenance.

10.2.4.2.2 Verify whether or not conditions of warranty have been met.

10.2.4.2.3 Provide relevant warranty information and recommendations for improvements.

10.2.5 Stipulations

10.2.5.1 Consumables such as tires, front casters, seat cushions, backrest cushions, etc. are not covered by the warranty.

10.2.6 Warranty Duration and Parts Covered by the Warranty

10.2.6.1 Please contact your local dealer.

---

## 10.2.7 Transfer of Warranty Rights

10.2.7.1 If you purchase a second-hand KARMA wheelchair while it is still

---

within the warranty period, bring this owner's manual and the wheelchair to the dealer where the wheelchair was purchased for registration.

Full Name:	
Gender:	
Date of Birth:	
Address:	
Model:	
Serial Number:	
Date of Purchase:	

Dealer's Data

Name of the Store:	
Phone Number and Address:	

If you have any suggestions on how to improve our products, please don't hesitate to contact your local dealer to let us know what you think of your wheelchair. Thank you and enjoy.