

311-145 JR. SLIDER (Perm)

IMPORTANT

PLEASE READ THESE INSTRUCTIONS BEFORE COMMENCING ASSEMBLY. Please retain this instruction sheet in your files. It contains important replacement parts information. All equipment must be installed in accordance with these instructions.

It is important to use and maintain all public playground equipment properly. Playground equipment, which is improperly maintained, can cause serious injury. Periodical inspections, maintenance, repair and/or replacement of damaged parts is necessary for safe operation of equipment. Appropriate publications, available at no charge, from the Consumer Product Safety Commission, include "A Handbook for Public Playground Safety". You can receive your free copy by calling 1-301-504-7908

Use of safety surfacing in compliance with the current ASTM specification F1292 is required.



PACKING LIST

1 CTN	1	Hardware Bag	3
	1 314-460	Slide Leg Holder	3
1 CTN	1 905-707	Stair	12
1 BDL	1 403-317	Entrance Rails	7
	1 103-306	2 3/8" OD. Slide Leg	7
1 CTN	1 313-428	Platform	1
2 WF	403-248	Guard Rail Leg Assembly	2 PR
1 SLIDE	1 435-600	Slide Bedway	2
1 BDL	1 383-461	Right Stair Rail	2
	383-462	Left Stair Rail	17
			14
			1
			10
			2
			2
			2
			1

HARDWARE BAG

3/8" Nylon Insert Lock Nuts
3/8" X 1" Button Head Bolts
5/16" X 1" Button Head Bolts
3/8" X 1" Hex Head Bolts
3/8" Lock Washers
1/4" Socket Key
1 3/8" "T" Clamps
1/2" X 1/2" Socket Set Screw
5/16" X 2 1/2" Button Head Bolt
3/8" Flat Washers
5/16" Lock Washers
7/32 Socket Key
5/16" Button Head Nuts
3/16 Socket Keys
Warning Label
SportsPlay Label
MAINTENANCE CHECKLIST

3 CTN	2 BDL	2 WF	1 SLIDE	8 TOTAL PCS	WT 390#	CLASS 70
-------	-------	------	---------	-------------	---------	----------

GENERAL USE/FALL ZONE & FOOTING RECOMMENDATIONS

STATIONARY & PORTABLE EQUIPMENT - USE/FALL ZONES SHOULD EXTEND A MINIMUM OF 6 FEET IN ALL DIRECTIONS FROM THE PERIMETER OF THE EQUIPMENT GROUND SPACE. THIS AREA SHOULD BE COVERED WITH THE REQUIRED AMOUNT OF RESILIENT SAFETY SURFACING MATERIAL. FOR SOME EQUIPMENT - USE/FALL ZONES CAN OVERLAP. SEE CONSUMER PRODUCT SAFETY COMMISSION GUIDELINES. DIAMETER & DEPTH OF FOOTING ILLUSTRATED ARE SATISFACTORY IN MOST APPLICATIONS FOR PIPE SIZES UP TO 2 3/8" DIAMETER. VARYING SOIL & CLIMATIC CONDITIONS MAY REQUIRE DEEPER & HEAVIER FOOTINGS IN SOME AREAS. CHECK LOCAL BUILDING CODES.

PERMANENT INSTALLATION:



* If resilient surfacing is to be less than 12", then additional pipe should be put in concrete to maintain proper finish grade for equipment.

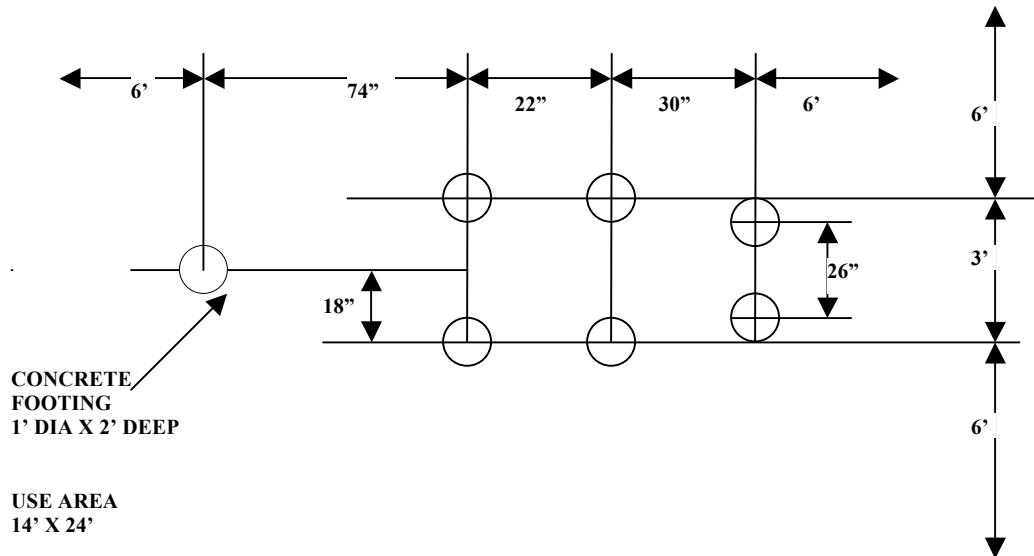

311-145 JR. SLIDER (Perm)

GENERAL ASSEMBLY INSTRUCTIONS:

Check all the parts and hardware with the packing list to be sure you have received everything needed to assemble this product. CONTACT YOUR LOCAL DISTRIBUTOR WITH NOTIFICATION OF ANY MISSING OR DAMAGED PARTS. Contact must be made within ten days of receipt of your order.

Only hand-tighten nuts & bolts on initial assembly. Final tightening should be done EVENLY after final assembly when unit has been plumbed & leveled. After assembly is complete, ANY ENDS OF BOLTS PROTRUDING BEYOND NUTS SHOULD BE CUT OFF AND/OR PEENED OVER TO REMOVE ANY SHARP EDGES. Go over entire unit to file smooth any sharp edges or projections that may have been caused by rough handling in shipping or installation. T-Clamps are designed for both one and two bolt connections. In many situations only one bolt is required. See specific assembly instructions. On products with platforms install 1 - 2 degrees off level to facilitate water drainage.

GENERAL MAINTENANCE INSTRUCTIONS:

Check MONTHLY for loose bolts, damaged or broken parts. Tighten and/or replace immediately.

SPECIFIC ASSEMBLY INSTRUCTIONS:

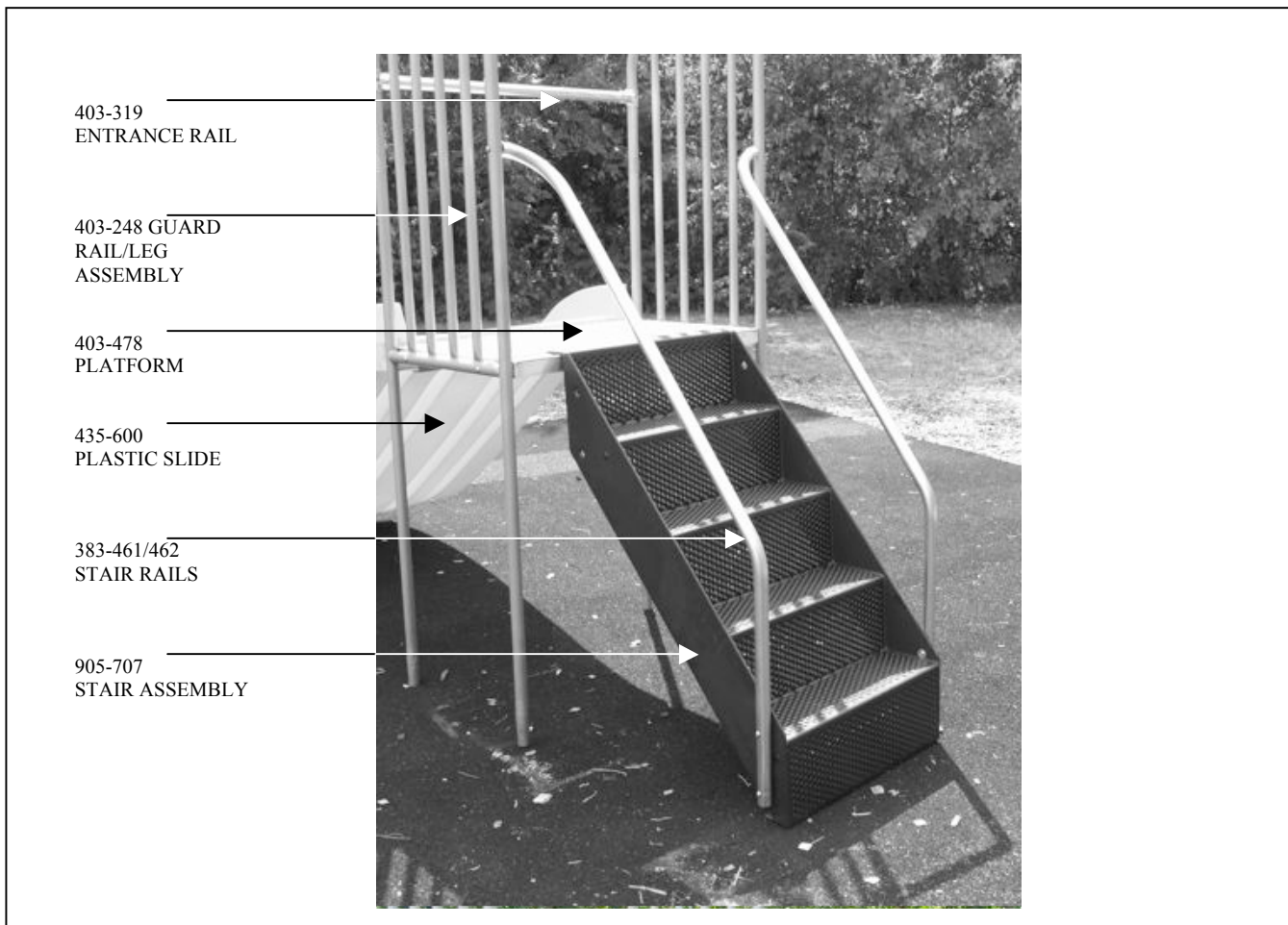

311-145 JR. SLIDER (Perm)

Page 4 of 5
Rev 04/12/10

- NOTE: Slide should be installed in shaded areas or face NORTH to prevent direct Sun on Slide's Chute.
- NOTE: All threaded ends of bolts protruding beyond nuts must be cut off and/or peened to eliminate sharp edges. No more than two threads should extend beyond face of nut.
- All washers, "T" nuts, and other fastener hardware used on round pipe or tubing must be hammered down to conform to the curved underlying surface to eliminate catch points.
- Do not fully tighten hardware until the unit is completely assembled
- STEP #1: Mark & dig footing holes per SKETCH on PAGE #2.
- STEP #2: Assemble Platform on the ground. Attach Guardrail Leg Assemblies 403-248. SEE PICTURE ON PG 3 AND REFER TO VIEW A FOR HARDWARE DETAILS
- STEP #3: Stand unit up, place it in the footing holes, level the unit and then brace it. Please note the orientation of the platform (one side of the platform is marked slide and one side is marked stairs) and orientate it in the desired direction. Attach the stairs using the 3/8 x 1" Button Head Bolts and 3/8" washers through the holes in the top of the stairs and through the platform, another 3/8" washer and into a 3/8" lock nut. Bolt the right and left stair rails on the proper side to the lower part of the stairs. (Refer to the side and front view illustration in View C) Attach the top of the stair rails to the guard wall.
- STEP #4: Attach the Slide Leg Holder to the bottom of the slide (view E) with 3/8 x 1" hex bolts, 3/8" washer and 3/8" lock washers. Place the slide leg into the slide leg holder and tighten set-screws (view F). Place slide leg into footing holes and attach the slide to the "Slide" side of the platform inserting the 3/8 x 1" hex bolts through the 3/8" washer, 3/8" lock washer, the back of the platform and into the factory installed nuts on the slide. (VIEW D). Using the "T" Clamps install the 403-319 Slide Entrance Rail above the slide (View B)
- STEP #5: Plumb & level. Tighten all nuts & bolts so that lock washers are flat. Pour Concrete. Wait 48 hours before removing braces, installing Resilient Surfacing & using equipment.
- STEP #6: Attach Warning Label and Manufacturer's Identification Label to a clean surface. The Labels should be attached in a location where they are clearly visible and legible and away from normal hand and foot placement areas. The Labels must be replaced if they become illegible, destroyed or removed. Contact your distributor for replacement Labels.

311-145 JR. SLIDER (Perm)

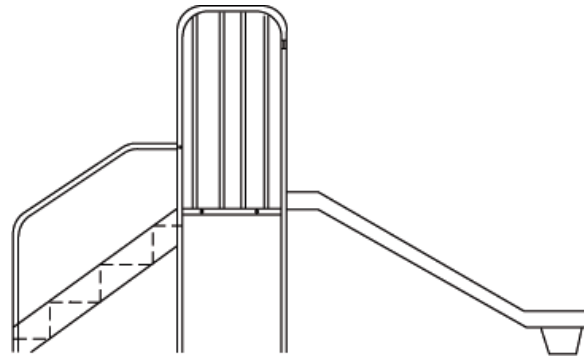

VIEW A

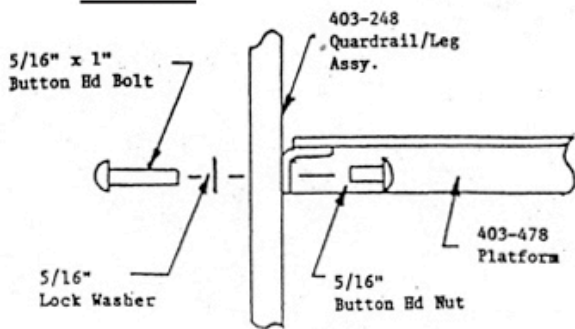

VIEW B

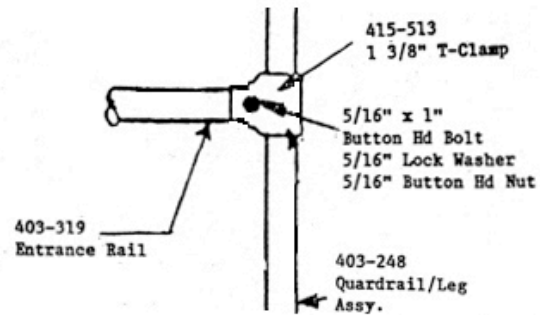

VIEW C

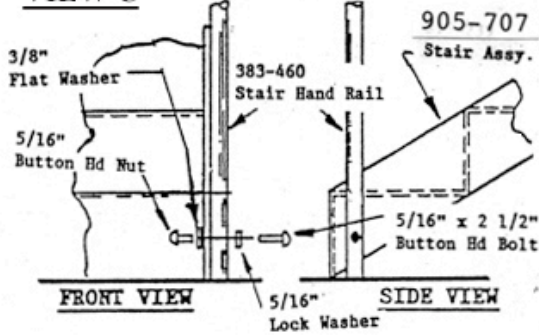

VIEW D

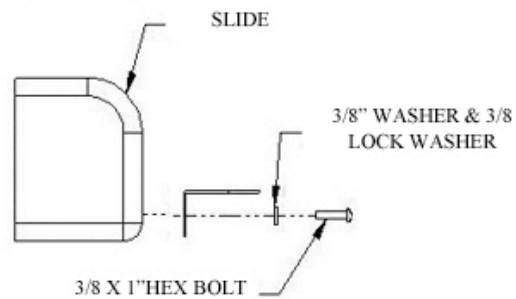

VIEW E

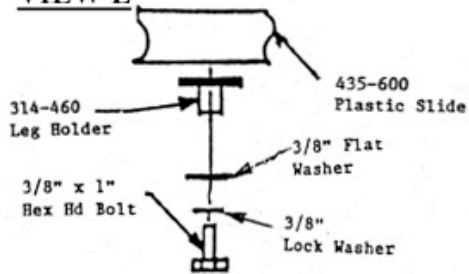

VIEW F

