

Safe•t mate[®] SM-014

**Wheelchair Anti-Rollback Device for
Invacare EX2 and non-reclining SX5**

INSTALLATION INSTRUCTIONS

Safe•t mate Model SM-008 rear anti-tippers (or a comparable style) are recommended when using this device.

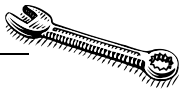

Before you begin!

Tools required:

- 7/16" open end wrench and socket
- 1/4" open end or small adjustable wrench
- 2 Phillips or straight screw drivers

PRECAUTIONS

The Safe•t mate is not designed for use with a solid drop seat or solid seat insert.

If the tires on the wheelchair are hard or brittle due to age, it may degrade the performance of this device. In this case we recommend replacing the tires.

This device is not a replacement for the factory installed brakes. The Safe•t mate Wheelchair Anti-rollback Device is a back-up system which may reduce injuries when factory brakes are not used.

Not a substitute for proper supervision. Supervise fall risk patients closely.



CALL US FIRST !

**For technical questions,
help with installation
or adjustments,**

service staff is ready to
provide friendly assistance.

If parts become damaged or
missing during shipping,
notify us immediately and
replacement parts will usually
ship from our facility
on the same day.



Authorized European Distributor

Homecraft Ltd.
Shelley Close, Lowmoor Road
Industrial Estate, Kirby-in-Ashfield
Nottinghamshire NG17 7ET, UK
Tel. 44 1623 759146
Fax 44 1623 726886

Lot No.

4 Digit number found on sticker
applied to inside of right actuator

Date Purchased:

____/____/____

Purchased From:

Before you begin, refer to parts list on page 5 to familiarize yourself with the components

1. Remove the bolts from the left and right **REAR** black plastic seat frame supports. (Diagram A)

Longer bolts are provided for this installation.

Retain original bolts to reuse in the event this anti-rollback device is removed.

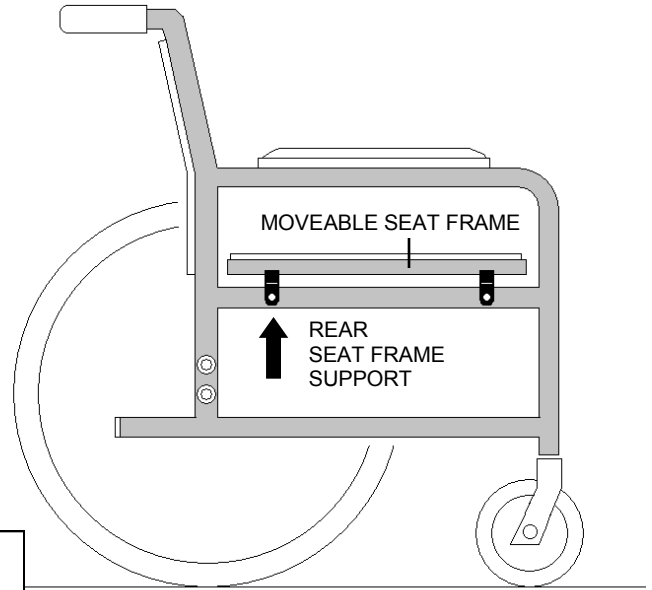

A

2. Slide Actuators into position from the rear of the chair as shown.

Left side shown in Diagram B

Left Actuator will have Brake Arm Support on right side (inside of chair) as shown.

Right Actuator will have Brake Arm Support on left side and Safe+mate label applied.

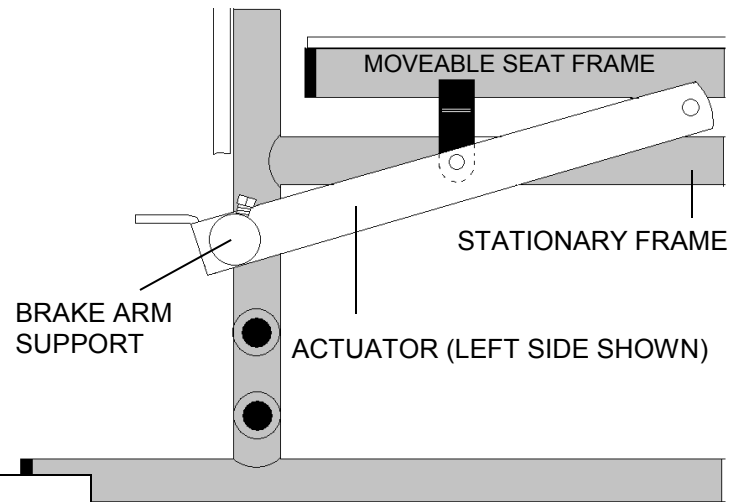

B

INSIDE OF LEFT CHAIR FRAME SHOWN

3. Insert the white nylon spacer in between the actuator and seat Support. (Diagram C)

- **Spacer on inside for fixed arm chair.**
- **Spacer on outside for removable arm chair.**

4. Slide 1/4" X 3" bolt through actuator, spacer, seat support, frame and spring. Thread 1/4" lock nut on until end of lock nut is flush with end of 3" bolt. (Diagram C)

NOTE The springs used in this step allow the actuators a non-rigid mounting with left to right play. This will enable the brake arms (Installed in Steps 7,8) to self-align as they engage the tires.

5. With the end holes of the actuator **above** the stationary frame member and **below** the moveable seat frame as shown in Diagram B, Install 1/4" X 2 1/2" bolt With two black spacers through the end holes of the actuator. Install 1/4" locknut and tighten securely.

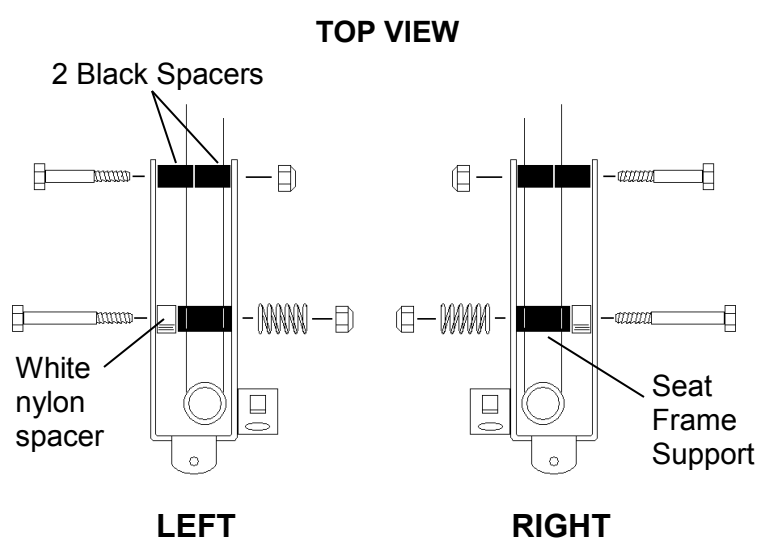

C

SHOWN WITH WHITE NYLON SPACERS ON OUTSIDE (FOR REMOVABLE ARM)

6.

Install the spring and ring.
First loop one end of the spring through the **small hole at the bottom** of the actuator (1) and the other end through one of 2 rings supplied as illustrated in Diagram D.

Next, push down on the ring to extend the spring enough to slide over the end of the frame tube as shown.

The spring has substantial tension so use caution when extending.

D

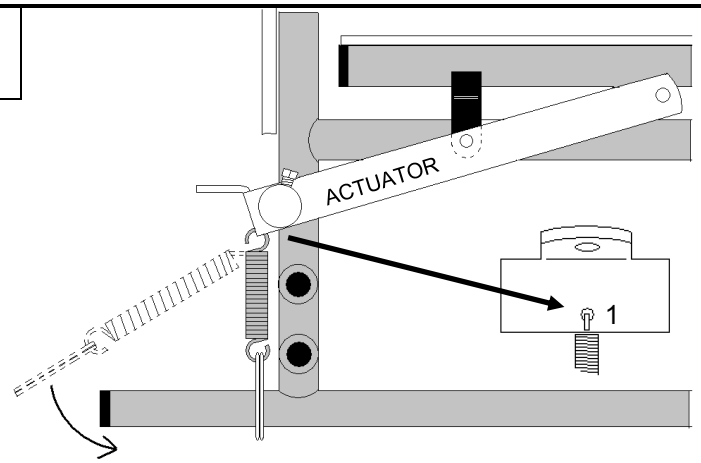

LEFT SIDE SHOWN

7.

Loosen Set Screws and Install Brake Arms.

There is a left and right brake arm. When installed correctly, the machined flats face Upward as illustrated in Diagram E.

First install black rubber protective caps on outer end of brake arms as shown.

Slide the brake arms into position with the tire grabbing portion of the arm looped around the tire as shown.

E

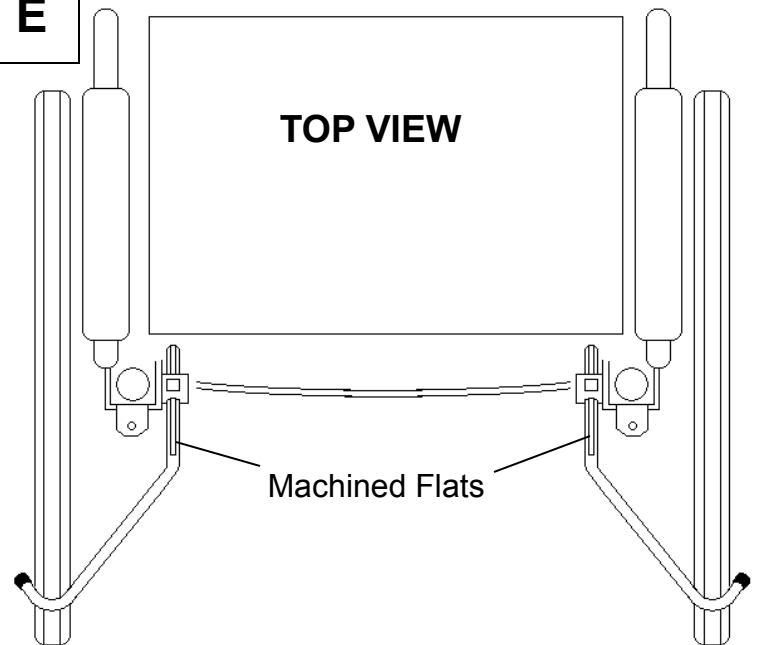

STEP 8 REQUIRES CHAIR SEAT TO BE OCCUPIED

8.

Adjust Brake Arms.
With the **chair seat occupied** (seat frame fully lowered onto seat frame supports), slide the wooden spacing dowel in between the brake arm and tire as shown in Diagram F.

While applying enough inward force on the brake arm to hold the dowel in place, securely tighten the set screw with 1/4" wrench.
Repeat for opposite side.

F

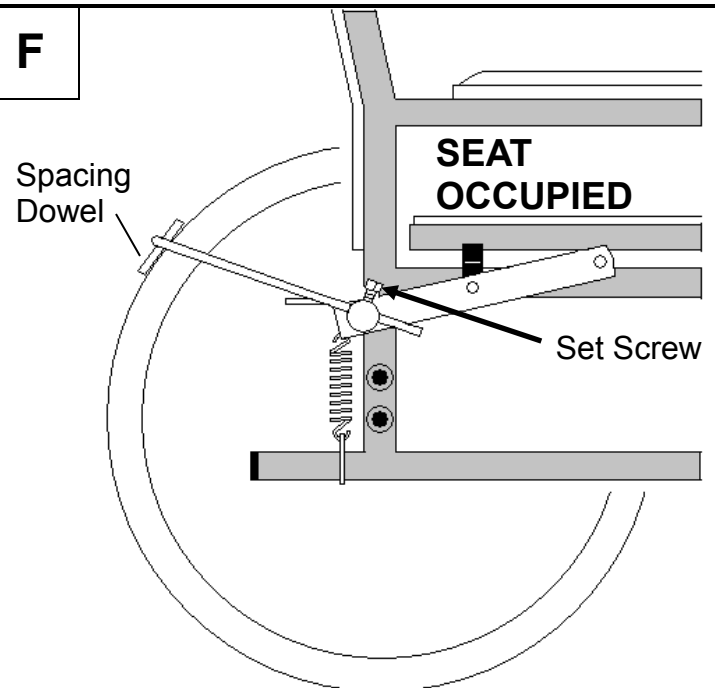

9.

Install Override Handles as follows:

Override rods come preinstalled on handles and the assemblies are swapped left or right depending on whether it is a removable or fixed arm chair. Refer to Diagram H below.

Remove top back upholstery screw / washer and insert handle clip. While holding clip in position as shown in Diagram G, reinstall screw / washer and securely tighten.

Slide Override rod into hole in actuator as shown.

Slide handle into clip and insert binder bolt and screw. Tighten securely.

SEAT SHOULD BE UNOCCUPIED FOR OVERRIDE ROD ADJUSTMENT

Install wing nut onto threaded portion of rod.

Insuring handle is all the way down, thread wing nut up until there is approximately 1/8" of play between the actuator and wing nut as illustrated in Diagram I.

Repeat for opposite side.

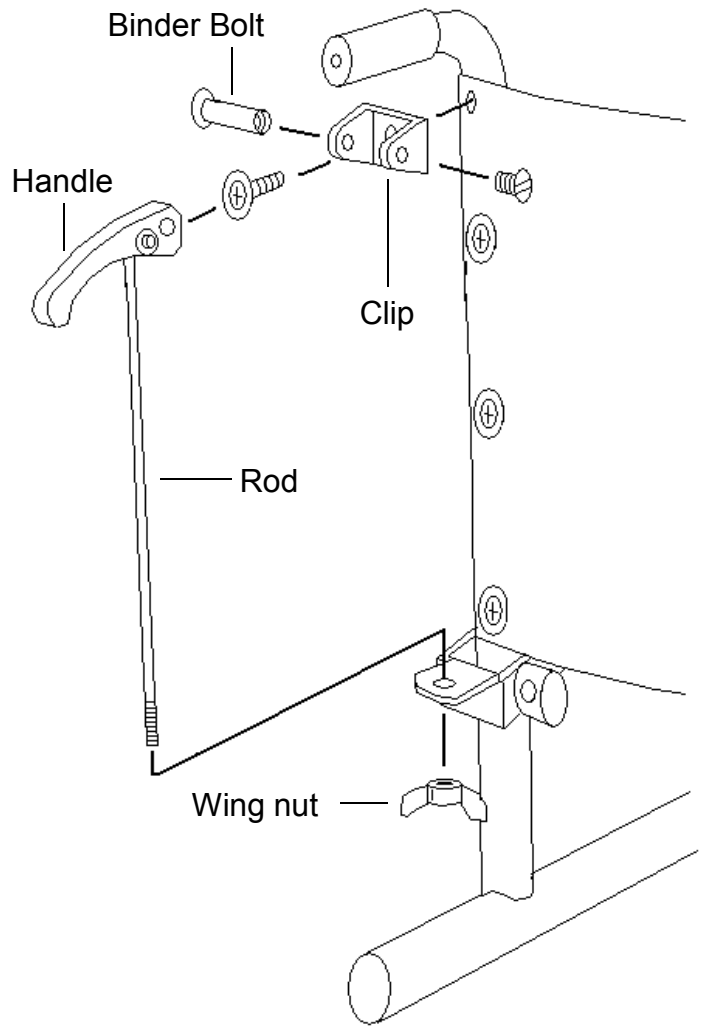

G

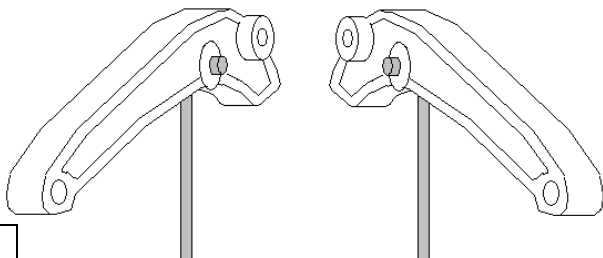
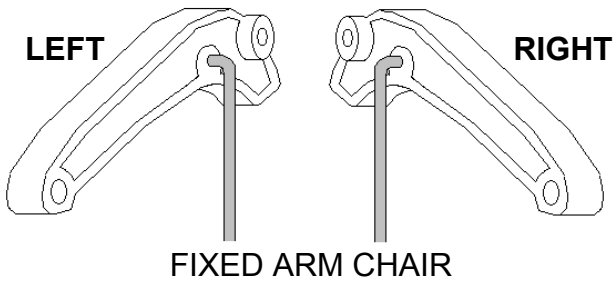

H

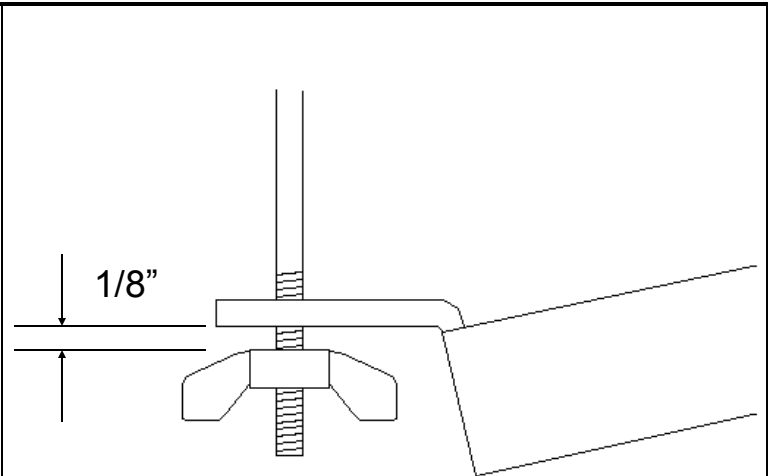

I

10. Check for proper installation and operation.

When the wheelchair seat is occupied, it will fully depress the seat frame. In turn, this will rotate the actuators slightly and lift the brake arms off of the tires. The wheelchair should now move freely in all directions.

As the wheelchair user begins to rise from the seat, the spring tension will lift the seat frame slightly and cause the brake arms to rotate down and grab the tires. As the tires try to rotate rearward, the brake arms will grab on and prevent the chair from rolling backward as the user attempts to exit or enter the chair.

The wheelchair will still move forward even with the brake arms engaged. The Override handles are provided to facilitate moving an unoccupied chair in reverse.

Parts Diagram

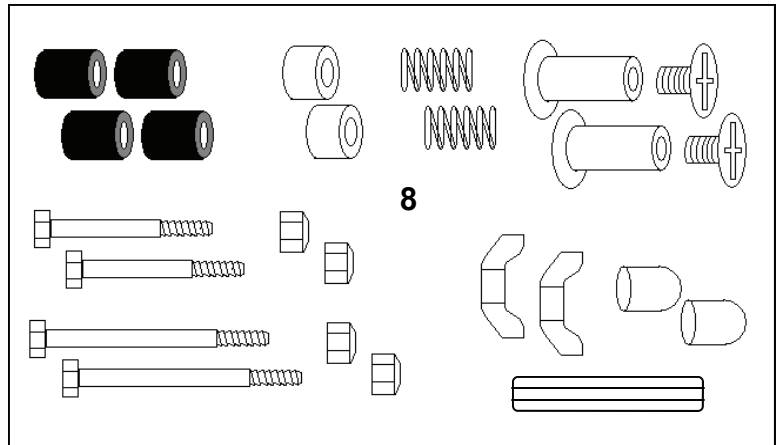
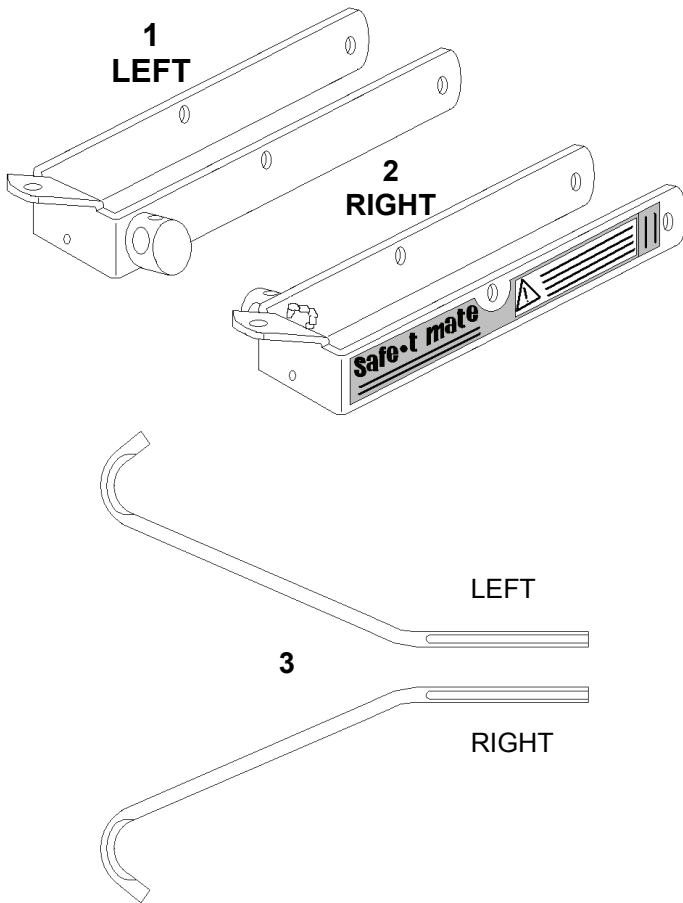

REF.	PART NO.	DESCRIPTION
1	014ACTUL	Left Actuator
2	014ACTUR	Right Actuator
3	014BAS	Brake Arm Set - Left and Right
4	014SPRINGS	Springs - Set of 2
5	014RINGS	Rings - Set of 2
6	014ORH	Override Handle / Rod Assembly - 2 required
7	014CLIP	Override Handle Clip - 2 required
8	014HWARE	2 1/4" X 3" Bolts, 2 1/4" X 2 1/2" Bolts, 4 Black Spacers, 2 White Spacers, 2 3/4" Springs, 2 Binder Bolts / Screws, 2 Wing Nuts, 4 1/4" Lock Nuts, 2 Rubber Caps, 1 Wooden Spacing Dowel

STAFF TRAINING TIPS

The Safe•t mate wheelchair Anti-rollback Device is designed to prevent a wheelchair from rolling back and away from the user as he/she attempts to sit down in or stand up from the chair. The chair will still move forward when the unit is engaged.

To facilitate moving the unoccupied chair in reverse, pull up on the temporary override handles to release the brake arms from the tires. **Do not attempt to rig the override feature to permanently disengage the device as this may cause a patient fall and serious injury.**

A wheelchair with the Safe•t mate Anti-rollback Device installed may be collapsed (for storage or transport) without affecting any adjustments. However, it is a good practice to check for proper operation after chair has been stored or transported in the collapsed position.

The Anti-rollback Device should be inspected periodically to ensure that all the mounting hardware is securely tightened and that the brake arms are in proper adjustment.

There is no need to remove this device prior to wheelchair washing. All components are made from moisture resistant materials.

Troubleshooting guide

Condition	Possible Cause	Check/Remedy
Brake arms do not lift off tires with seat occupied	Step 8 not performed with chair occupied	Review installation instructions
Only one brake arm grabs tire when patient rises from chair	Unbalanced brake arm spacing	Repeat Step 8 brake arm adjustment
Brake arms contact tires but do not prevent rollback when force is applied	Override rod wing nut adjustment needs to have specified play to allow brake arms to fully engage tires	Repeat Step 9 Wing nut adjustment Refer to Diagram I
Brake arms rotate out of position or loosen	Loose set screws or left and right brake arms swapped.	Ensure machined flat surfaces face up, readjust and FIRMLY tighten set screws Thread locking compound may be applied if needed
Override handles do not lift brake arms off of tire surface	Improper wing nut adjustment Brake arm adjustment done with chair unoccupied	See Step 9 and Diagram I Repeat Step 8 with chair occupied

Warranty

The SM-014 is warranted to be free from defects in material and workmanship under normal operating conditions for a period of **one year**. 210 Innovations sole obligation under this warranty is limited to repair or replacement of defective parts. This warranty does not cover failure due to abuse, misuse, alteration, improper assembly or installation. Please contact us at **800-210-2298** or **www.safetmate.com**