

501-118 Hercules III

IMPORTANT

PLEASE READ THESE INSTRUCTIONS BEFORE COMMENCING ASSEMBLY. All equipment must be installed in accordance with these instructions. Check your shipment against Bill of Lading and Parts list. Any missing or broken parts must be reported to your distributor within 10 days of receipt of your order. When properly installed and maintained, equipment will give many years of Safe, Trouble-Free use. Periodically check for loose or broken parts. Loose bolts must be tightened and broken parts must be replaced as they can possibly create dangerous situations leading to unnecessary accidents. Resilient Surfacing should be used under all playground equipment. Appropriate publications, available at no charge, from the Consumer Product Safety Commission, include "A Handbook for Public Playground Safety". You can receive your free copy by calling 1-301-504-7908.

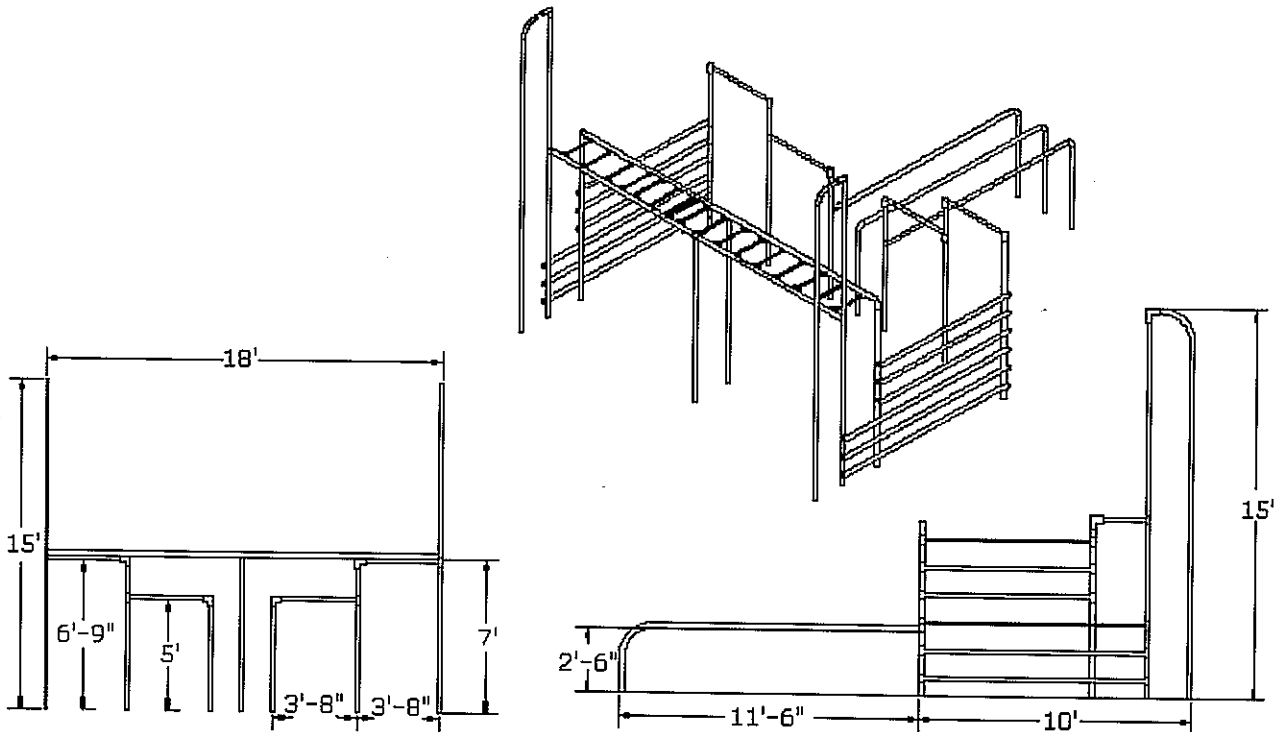

PACKING LIST

1 CTN	1	Hardware Bag
	4	503-501 2 7/8" Elbow
	2	513-511 Adaptor
2 BDL	3	503-217 Rail
2 BDL	3	503-218 Rail
1 BDL	2	503-230 Turning Bar
	2	503-231 Turning Bar
1 BDL	2	503-626 Post
1 BDL	2	503-627 Post
2 BDL	2	503-628 Post
1 WF	1	503-319 Ladder
2 PIPE	1	503-629 Post
2 PIPE	1	503-630 Parallel Bar
1 PIPE	1	503-631 Parallel Bar
2 PIPE	1	503-632 Slide Pole
2 PIPE	1	503-622 Pipe

HARDWARE BAG

24	105-015	1 5/8 Alum Pipe Plug
6 pr	125-523	2 3/8" OD T-Clamp
30	116-555	5/16" x 3 1/4" Button Head Bolt
12	116-545	5/16" x 2 1/2" Button Head Bolt
16	196-802	1/4" x 1/2" Socket Set Screw
42	326-501	5/16" Lock Washer
42	216-512	5/16" Button Head Nut
2	416-350	3/16" Socket Key
1	416-400	1/4" Socket Key
2	805-532	Warning Label
2	805-534	SportsPlay Label
1		Maintenance Checklist

1 CTN	9 BDL	1 WF	9 PIPE	20 TOTAL PCS	WT 850#	CLASS 70
-------	-------	------	--------	--------------	---------	----------

GENERAL USE/FALL ZONE & FOOTING RECOMMENDATIONS:

Use/Fall Zones should extend a minimum of 6 Feet in All Directions from the Perimeter of the Equipment Ground Space. This area should be covered with the required amount of Resilient Safety Surfacing Material. For Some Equipment Use/Fall Zone can Overlap. See Consumer Product Safety Commission Guidelines.

Diameter and Depth of Footing Illustrated are Satisfactory in Most Applications for pipe sizes Up to 2-3/8" Diameter. Varying Soil and Climatic conditions may require Deeper and Heavier Footings in Some Areas. Check Local Building Codes.

Typical Upright Footing Installation

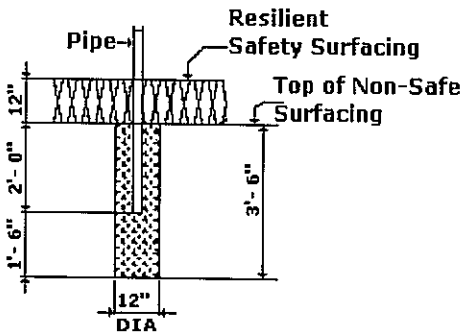

Concrete Footing (Upright)

Typical Angled Footing Installation

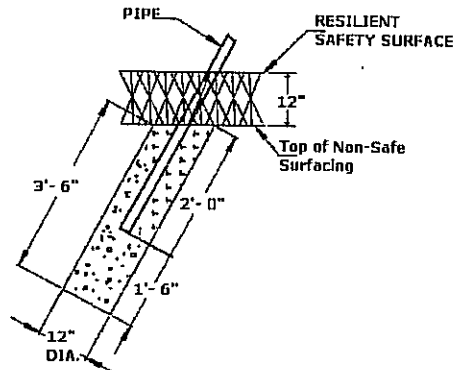

Concrete Footing (Angled)

Suggested Bracing Method

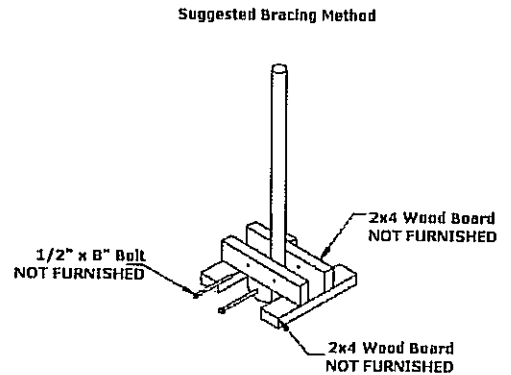

* If resilient surfacing is to be less than 12", then additional pipe should be put in concrete to maintain proper finish grade for equipment.

501-118 Hercules III

USE AREA AND FOOTING LAYOUT:

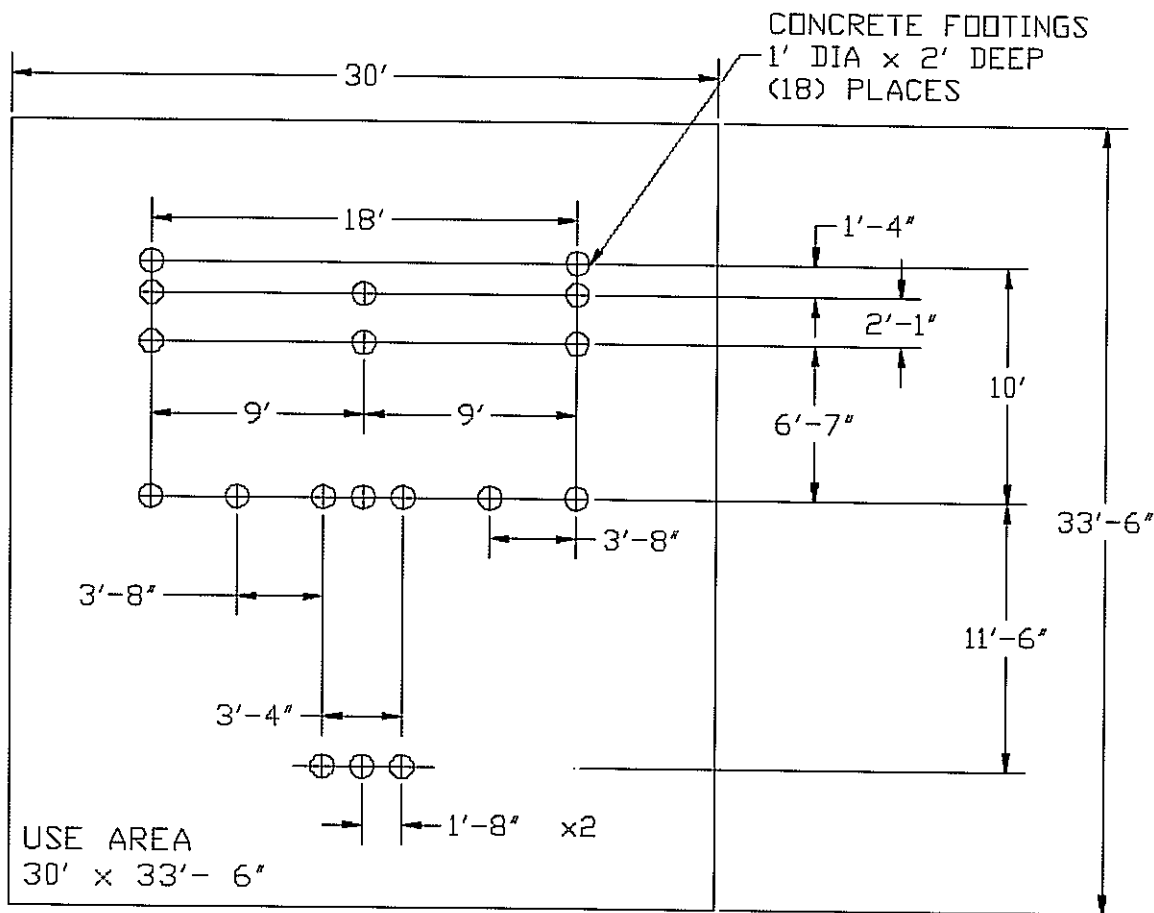

501-118 Hercules III

PARTS DIAGRAM:

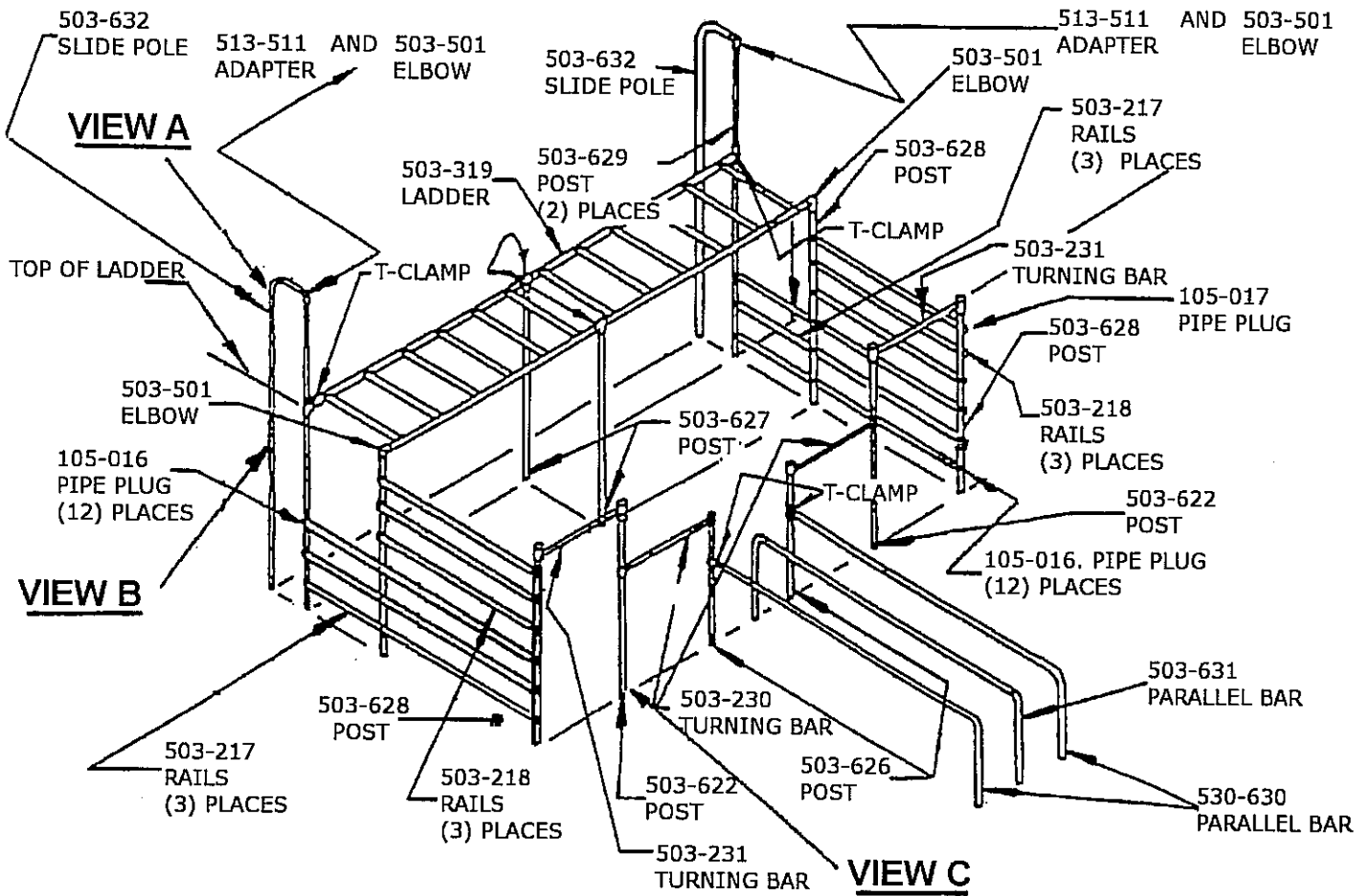

501-118 Hercules III

Page 5
Rev 06/20/08

GENERAL ASSEMBLY INSTRUCTIONS:

Check all the parts and hardware with the packing list to be sure you have received everything needed to assemble this product. CONTACT YOUR LOCAL DISTRIBUTOR WITH NOTIFICATION OF ANY MISSING OR DAMAGED PARTS. Contact must be made within ten days of receipt of your order.

Only hand-tighten nuts & bolts on initial assembly. Final tightening should be done **EVENLY** after final assembly when unit has been plumbed & leveled.

After assembly is complete, **ANY ENDS OF BOLTS PROTRUDING BEYOND NUTS SHOULD BE CUT OFF AND/OR PEENED OVER TO REMOVE ANY SHARP EDGES.** Go over entire unit to file smooth any sharp edges or projections that may have been caused by rough handling in shipping or installation. T-Clamps are designed for both one and two bolt connections. In many situations only one bolt is required. See specific assembly instructions.

On products with platforms install 1 - 2 degrees off level to facilitate water drainage.

GENERAL MAINTENANCE INSTRUCTIONS:

Check **MONTHLY** for loose bolts, damaged or broken parts. Tighten and/or replace immediately.

SPECIFIC ASSEMBLY INSTRUCTIONS:

- NOTE:** All threaded ends of bolts protruding beyond nuts must be cut off and/or peened to eliminate sharp edges. No more than two threads should extend beyond face of nut.
All washers, "T" nuts, and other fastener hardware used on round pipe or tubing must be hammered down to conform to the curved underlying surface to eliminate catch points.
- STEP #1:** Mark & dig footing holes per Layout on PAGE #3.
- STEP #2:** Assemble horizontal ladder portion of assembly. See detail B. If desired, height of sliding pole can be lowered as much as 36" and still meet C.P.S.C. minimum height of slide pole post over access point. Cut desired length off TOP of posts (503-629) & BOTTOM of Slide Pole (503-632)
- STEP #3:** Brace other two Corner Posts (503-628) in footing holes. Attach Bottom Rails (503-217), then Top Rails (503-218). See Detail C
- STEP #4:** Assemble 2 sets of Turning Bars Posts (503-622 & 503-626) with Turning Bars (503-230). Brace in footing holes. See Detail C. The 5' high Turning Bar height can be lowered as much as 2' if desired, by cutting the desired amount off the top of the Posts (503-626)
- STEP #5:** Attach Top Turning Bars (503-231).
- STEP #6:** Brace parallel bars in footing holes. Attach Posts (503-626) with T-Clamps.
- STEP #7:** Attach Slide Poles (503-632) to Post (503-629). See Detail A. Brace in footing holes.
- STEP #8:** Plumb & level. Tighten all nuts & bolts so that lock washers are flat. Pour concrete. Let stand 48 hours before removing braces, installing resilient surfacing and using equipment.
- STEP #9:** Attach Warning Label and Manufacturer's Identification Label to a clean surface. The labels should be attached in a location where they are clearly visible and legible and away from normal hand and foot placement areas. The labels must be replaced if they become illegible, destroyed or removed. Contact your distributor for replacement labels.

501-118 Hercules III

DETAIL DRAWINGS:

