

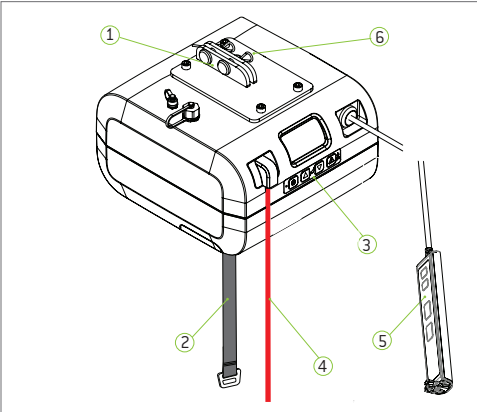

Important! This quick reference guide does not replace the user manual which can be downloaded at www.humancaregroup.com.
Read all instructions before use!

Components



- 1 Connector for Rail Roller
- 2 Lift Belt
- 3 Secondary Panel
- 4 Emergency Stop Belt
- 5 Hand Control
- 6 Mounting Pins

Secondary Panel Functions

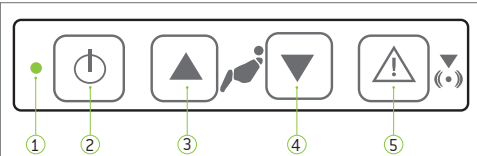

- 1 Status Indicator Light
- 2 Power On/Off
- 3 Raise Lift
- 4 Lower Lift
- 5 Emergency Lowering

Status Indicator Lights

- Flashing Green**
On/Ready for Use Full Battery
- Flashing Yellow**
On/Ready for Use Charge Battery Warning
- Flashing Red**
On/Ready for Use Low Battery
- Constant Green**
Lift in Use Lift Loaded
- Constant Red**
Safety Catch Engaged Troubleshooting!
- Constant Yellow**
Lift Charging Functions Blocked
- Flashing Green/Yellow**
Service Warning Perform Inspection
- Flashing Red/Yellow**
Service Passed Battery Low



Important! This overhead lift has been designed and tested for indoor use with one patient at a time. This product must not be immersed in water.
Read all instructions for full product information!

Hand Control Functions

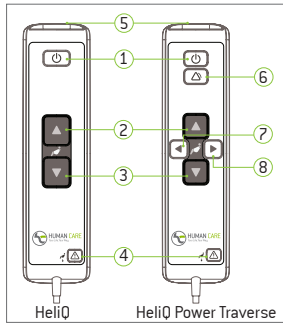

- 1 Off/On Button
- 2 Up Button
- 3 Down Button
- 4 Emergency Lowering
- 5 USB and Charge Port

- For Power Traverse only:
- 6 Alarm Button
 - 7 Lift backwards
 - 8 Lift forwards



Important! The covers for the USB input and the charging input (3) must be closed for the hand control's water protection (IPX5) to be valid.

Charging the Lift

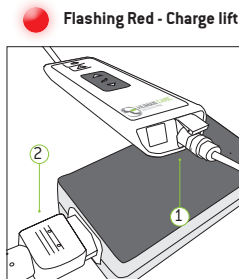

- Flashing Red - Charge lift immediately!**
- 1 Connect charger plug to handset.
- 2 Connect plug to charger and insert plug into wall to charge. The charger must only be connected to an earthed socket.
- Note: If the emergency stop is activated, the lift will not charge!



Important! The lift can only be used with a Human Care charger and must be disconnected to use the lift.

Models: 55000, 55010, 55020
(PT) 55005, 55015, 55025
Human Care HC AB. All Rights Reserved.



Using the lift

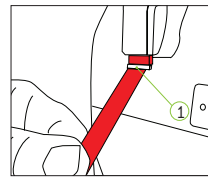

Emergency Stop Activation
Pull red belt to activate.

Emergency De-Activation
Push up activation plate (1) located at top of emergency stop belt.



Important! Emergency lowering must only be used in emergency situations. There will be a 3 second delay.



To activate, press handset "Down" button (3) and secondary panel emergency lowering button (5) at the same time.

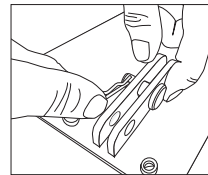

Suspending the lift
The lift is mounted directly to the rail roller which is located in the rail. **Do not use any distance straps.** Remove mounting pins holding bolts in place. Remove bolts and line up holes in rail with holes in rail roller. Replace bolts through holes and secure in place with pins. To detach, reverse process.



Important! The belt must remain taut while being fed into the lift.

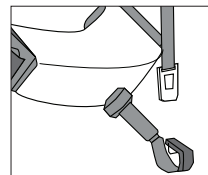

Hanger bar
Lower the lift strap to a comfortable working height. Connect hanger bar to lift by hooking hanger bar diagonally from beneath the lift strap.



Slings
Use hand control to position carry bar directly above patient. Attach head sling loops to carry bar first, then leg straps.



Proper lifting techniques
Do not use the hanger bar to move the patient and the lift. Do not hold onto the hooks while performing a lift. Once the patient is comfortably secured in sling, raise lift, hold sling and position/move patient.

General Care

Charge lift every night.

Wipe down with slightly dampened drying cloth.

Disinfect with DuPont™ Virkon®.

Never use strong detergents on lift.

Do not immerse in water.

Activate emergency stop when not in use.



Important! Do not use strap to transport!
If lift is removed from ceiling mount, it must always be stored or moved in a horizontal position. Rest on cart to move.

Inspection

Annual Inspection - The lift must be inspected at least once per year by a qualified technician certified by Human Care.
Monthly Inspection - Check lift belts for damage or wear. Feed entire length to ensure proper functioning.
Daily Inspection - Always inspect the lift for visible signs of damage before use. Ensure the lift is correctly mounted on the distance strap or rail roller. Always check slings and belts for signs of wear before use. Do not use if wear evident.

Troubleshooting

- If the indicator light is not on, check the following:**
 - Mains switch is on
 - Batteries do not require charging
 - Emergency stop is not activated
- If the indicator light is flashing, check the following:**
 - Check the hand control button functions up / down when depressed (replace if necessary)
 - When pressing up, the lift is not already in its maximum upper position
 - When pressing down, the lift is not already in its maximum lower position
- If the indicator light is constant red:**
 - The lift motor is overheated - allow to cool
 - The lift is overloaded - lower using emergency lowering button
- If the indicator light is constant yellow:**
 - Charging in progress
- If the indicator changes to flashing red:**
 - The batteries need charging, patient may be lifted a few more times