

Swim-Lift[®] Gallatin WP400

Part Numbers: 27336-00, 27332-00, 27335-00, 27333-00



Owner's Manual Assembly, Installation and Operation

27336 - Man Rev A

Thank you for purchasing the Swim-Lift® Gallatin. Providing that the unit is installed correctly and properly maintained, it will furnish you with many years of trouble free use. It is important to read this entire manual before beginning assembly or operation.

INDEX

Unpacking and Inspection	3
Material and Tool Requirements	3
Assembly Drawing	4
Anchor Installation	5
Lift Assembly	7
Lift Operation	9
Care and Maintenance	10
Troubleshooting	11
Two Year Limited Warranty	12

UNPACKING AND INSPECTION

Reminder: It is your responsibility to inspect product shipments, check for the following:

- Check the number of cartons/boxes/crates against the shipper's bill of lading
- Check the cartons/boxes/crates for freight damage

Please refer to our published freight policy in our General Catalog for further details.

If freight and/or handling damage, or shortage of cartons/boxes/crates should occur, it is your responsibility to file a claim with the freight carrier. You must note the damage or shortage on the freight carrier's bill of lading before accepting shipment.

It is Spectrum's desire to provide superior products and services. Unfortunately we cannot control circumstance related to the shipment of products beyond our freight docks. However if you have any questions or problems related to your shipment, please feel free to contact us at 800-791-8056, and we will make every effort to assist with freight problems. Ask to speak with our Customer Service Support Department.

The Gallatin is shipped in one box and is partially assembled. Before accepting the Gallatin from the carrier, inspect the skid and its contents for visible damage and verify receipt of all components. Unpack and match the contents as listed below.

Contents:

___ (1) Headrest Bar with White Spectrum Headrest	___ (1) 13289 Seat Frame Assembly w/Grips
___ (1) 13900 Flip Up Footrest w/ HDPE White Footboard	___ (1) Hardware Box
___ (1) 540250-03 50' Garden Hose	___ (1) Cleaning Kit
___ (2) 26293 Molded Seat Half Top/Bottom	___ (1) Literature

Material and Tools Requirements

The following materials and tools are required for assembly and installation:

- Rotary impact drill (retrofit anchors only)
- 1/2" diameter concrete drill bit (retrofit anchors only)
- Hydraulic cement or two-part epoxy
- Socket wrench
- 9/16" deep well socket (retrofit anchors only)
- 3/4" socket or wrench
- 9/16" socket or wrench
- 1/2" socket or wrench
- 15/16" open end wrench
- 7/64" hex key (Allen) wrench
- Carpenters' level
- Marking pen or chalk (retrofit anchors only)
- Spanner wrench (provided)
- Hammer (retrofit anchors only)
- Torque wrench

ASSEMBLY DRAWING

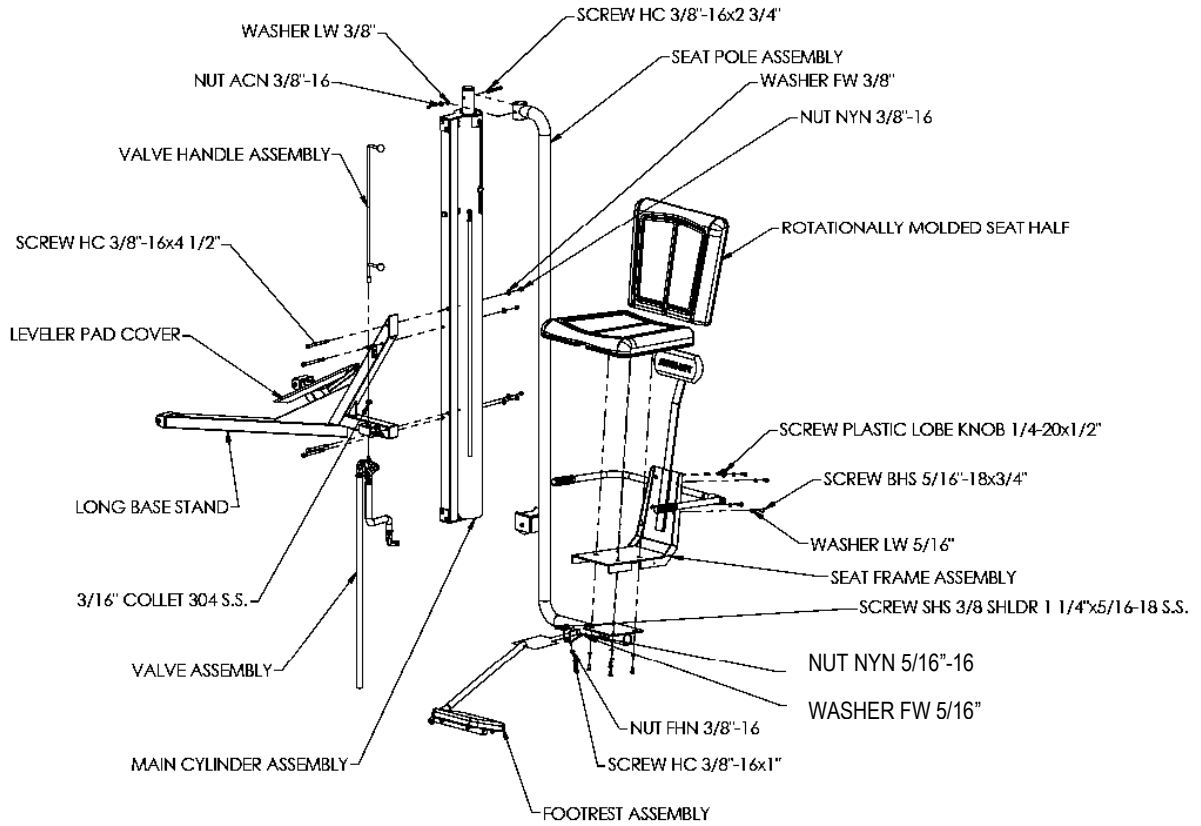

Figure 1

Anchor Installation

If you purchased and installed a Swim-Lift® Pre-Set Anchor previously or if your Retro-Fit Anchors are already installed, please proceed to the Lift Assembly Section on page 7.

Anchor Location

It is recommended that the Gallatin be installed in or near the shallow end of the pool with sufficient deck space and operational area in the pool as shown in figure 2. For reasons of safety and ADA guidelines, the lift must be installed in a location that is clear from the obstacles and other hazards.

NOTE: Do not locate the lift in a corner or directly adjacent to pool ladders/handrails or grab rails that could interfere with the rotation of the lift. Do not place the lift where it may be cumbersome or hazardous to any pool users.

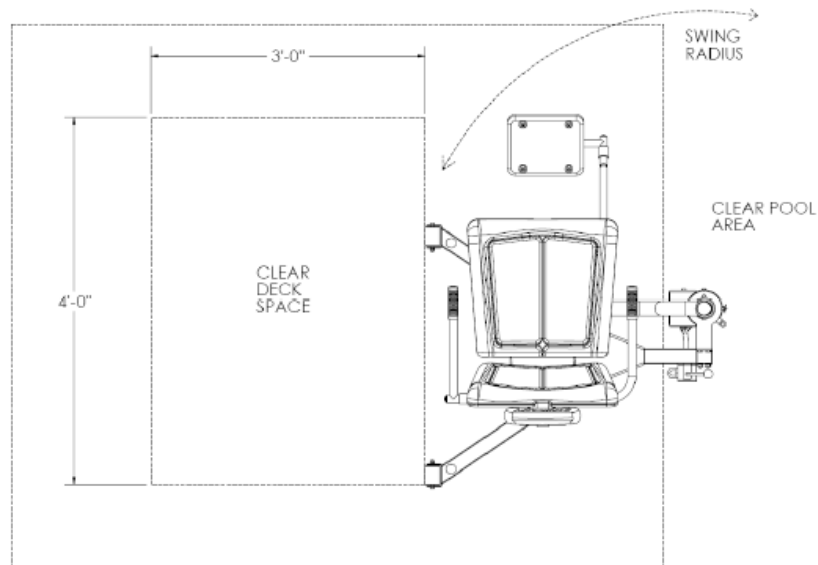

Figure 2

Because the lift can be stopped at any position during lowering, there is no minimum pool depth requirements for the Gallatin. However, to comply with ADA guidelines, the Gallatin must be installed at a pool depth no greater than 48-inches and the seat should submerge to a minimum depth of 18" below the surface of the water. For the standard base anchors may be installed between 20" and 30" from the pool/spa edge with the recommended anchor setback at 28". For the Short base anchors may be installed between 18" and 24" back from the pool/spa edge with recommended anchor setback at 22". Make sure that the center of both anchors are the same distance from the edge of the pool. Refer to figure 3 to optimize the position of the leveler foot. There must be at least 6" from the center of each anchor to the nearest joint, crack, curb or similar concrete structure to ensure the strength of the concrete.

In addition, all installations should be in accordance with the ADA guidelines (ADA guidelines are available at the website www.access-board.gov).

NOTE: Optional base stand configurations are available if this setback range or anchor location will not work with your pool.

Anchor Installation

1. Mark the location of each anchor on the deck and use a $\frac{1}{2}$ " diameter concrete drill bit to drill a 4" deep hole at each location. Make sure to drill straight down.
2. Use a 1- $\frac{1}{2}$ " diameter concrete core drill to drill out the anchor holes to a depth of 2- $\frac{3}{16}$ " as shown in figure 4. Clean all of the debris from the holes. Check to see if the bottom of each hole is in solid concrete. The anchors will only hold if the surrounding concrete is solid. The top of the anchor should be $\frac{1}{4}$ " below the deck surface. The anchors can be installed deeper, if necessary, to mount sufficiently solid concrete.

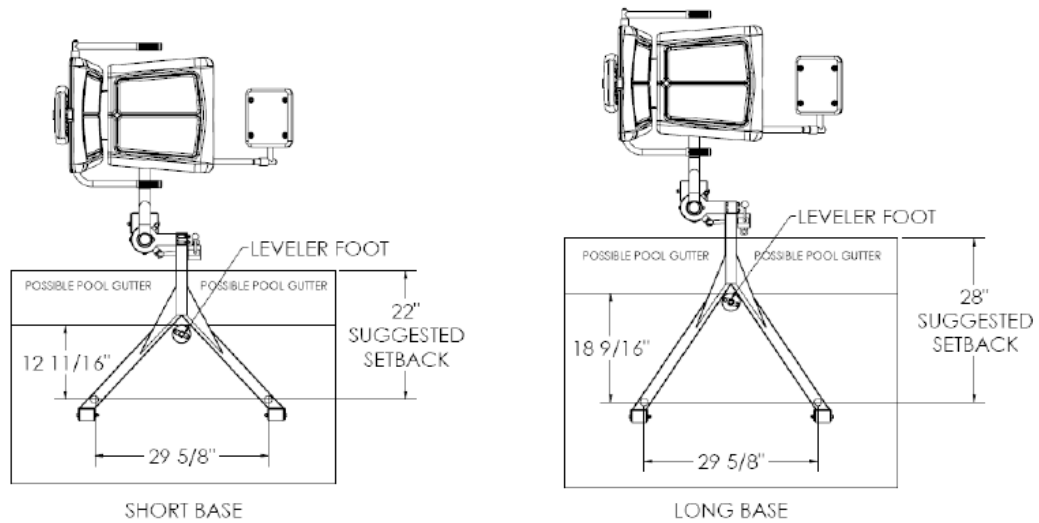

Figure 3

3. Use a small amount of two-part epoxy or hydraulic cement in each anchor hole and set an anchor into each hole. Set the expansion anchor at the bottom of the anchor hole by tapping the anchor pin with the supplied $\frac{1}{4}$ " diameter set tool rod with a hammer. Use a $\frac{9}{16}$ " deep well socket to tighten the internal anchor bolt to approximately 30 ft-lbs. torque. Allow sufficient time for the epoxy or cement to completely harden before installing the lift in the anchors.

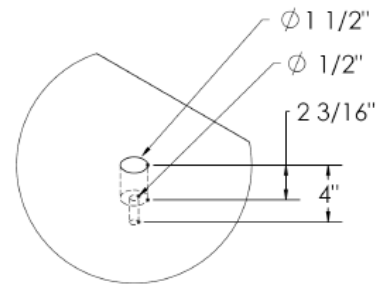

Figure 4

4. Locate a bonding source to bond (ground) the anchor. The steel rebar-bonding grid of the pool deck is the best choice for bonding the anchor. Attach the No. 8 solid copper wire (not included) from the bonding bolt on the base of the anchor to the bonding grid.

NOTE: Article 680 of the National Electrical Code requires bonding of all metallic components in relationship to pools and spas.

Lift Assembly

1. Attach the base of the Cylinder Support Column Assembly with four 3/8" – 16 x 4-1/2" hex head bolts protruding from the support column, as shown in figure 1. Secure the base with four 3/8" Flat washers and four 3/8" acorn nuts, torque to 20 ft-lb.
2. Install the Pressure Wheel and the Pressure Wheel Guard using a 3/8"x 5 1/2" hex head bolt, Two 3/8" flat washers, a 3/8" lock washer, and a 3/8" acorn nut.
3. Mount the valve to the valve bracket on the base as shown in figure 1. Use the brass hardware supplied with the valve.
4. Remove the upper valve handle knob from the valve handle and slide the valve handle through the handle valve bracket. Match the flat on the valve post to the flat on the inside of the valve handle sleeve and slide the valve handle onto the valve post. Replace the upper valve handle knob on the valve handle.

NOTE: The two-piece collar on the valve handle and slide the valve handle in place and may need to be repositioned. To move the collar, loosen the screws in the collar using a 7/64" hex key wrench. Move the collar so that it is just below the valve handle bracket and retighten the screws. See Figure 1.

4. Screw the Leveler Pad into the base assembly as shown in figure 4.
5. Bolt the lift to the anchors in the deck using two 1" diameter by 4" length acme bolts as shown in figure 5. **Do not completely tighten the 1" diameter acme bolts at this time.**
6. Attach the Seat back to the Seat Frame with four 5/16" – 18x3/4" Button head screws torqued to 11 ft-lb, as shown in figure 1.
7. Attach the Seat bottom to the Seat Pole by using two 5/16" – 18 x 1" Button Head screws. First install a 5/16" – 18 x 1" button head screw and insert this through one of the two front holes of the Seat arm plate, then through the seat frame and then finally set the screw into the seat bottom as shown in figure 1, loosely.
8. After the Seat assembly has been secured with the two front 5/16" - 18 x 1" Button head screws, insert two 5/16" – 18 x 1" Button head screws through two 5/16" flat washers and then through the Seat belt grommets and into the Seat assembly tightening all 5/16" - 18 x 1" Button head screws to 11 lb-ft at this time, as shown in figure 1.
9. Level the lift front to back, if necessary, by using donut shims between the base stand and each anchor, and adjusting the Leveler Pad by screwing the Pad in or out. The donut shims can be used individually or in combination to level the lift. The donut shims can be used above the anchor base or below as shown in figure 5 to prevent the acme bolts from bottoming out in the anchors.
10. Check that the cylinder is perpendicular to the deck in all directions with a carpenter's level. Adjust the Leveler Pad or change donut shims at each anchor to level the lift. If the lift is not installed level and perpendicular, it may lower the lifting capacity, reduce the operational life of the lift or void the warranty.

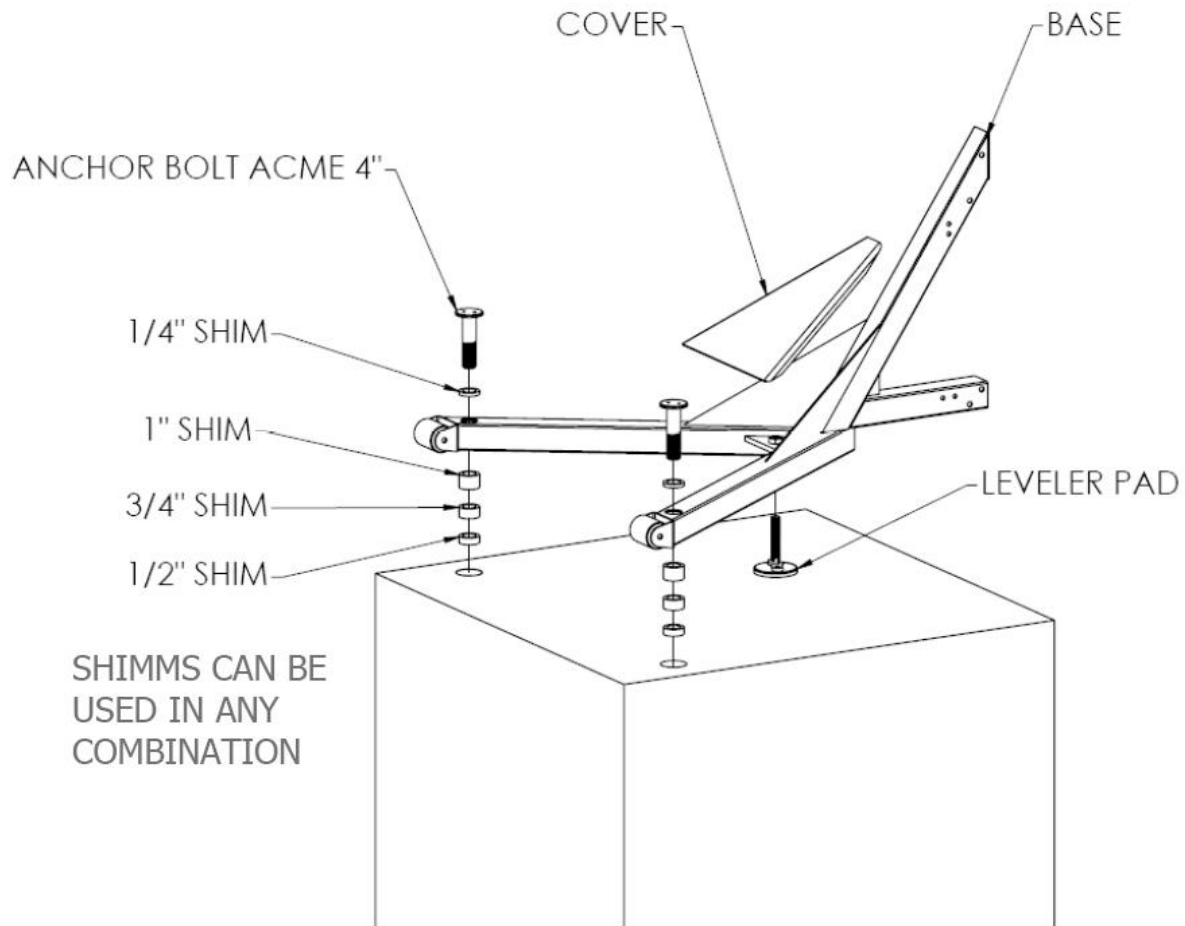

Figure 5

11. Install Cover on lift as shown in figure 5.
12. Connect Flip up footrest using one 3/8" – 16 x 1 1/4" Socket head shoulder screw, a 3/8" Flat washer and, 3/8" nylock nut torque to 20 ft-lb as shown in figure 1.
13. Connect the water supply to the female garden hose coupling on the control valve. After purging the air from the cylinder the Swim-Lift® Gallatin is ready for operation.

Lift Operation

WARNING ! Read all of the operating instructions before operating the lift. Make sure that all individuals using the lift have read the instructions and have been made aware of all safety precautions.

WARNING ! Do not exceed the maximum lifting capacity 400 lbs (181.4 kg). This may result in damage to the lift or personal injury. Other lift models are available for loads in excess of 400 lbs.

The Swim-Lift® Gallatin is a water-powered lifting aid designed with use for water systems that have a 55 PSI rating. This lift will function with as little as 45 PSI water pressure. Optional pump kits are available for supplying a constant pressure of 55 PSI. Lifting capacities are based on a continual pressure supply without pressure drops occasionally incurred during peak demand periods of city water systems. The lifting capacity/pressure ratios are as follows:

<u>Pressure</u>	<u>Lift Capacity</u>
55 PSI	400 lbs.
50 PSI	350lbs.
45 PSI	300 lbs.

A backflow check valve may be required on this lift to prevent contamination of the municipal water supply. Please check your state and local codes to see if a backflow check valve is required.

Lift Preparation:

1. Turn the control valve to the intermediate stop position and attach the water supply hose to the valve. Turn the water supply on.
2. With no weight on the chair, turn the control valve handle to the up position. Allow the chair to fully rise.
3. Turn the control valve handle to the down position. Allow the seat to lower to a fully down position. Repeat steps 2 and 3 until a smooth operation is attained. This process purges the air from the system and should no more than 5 to 7 cycles to complete.

Lift Operation

1. Lift operation is controlled through the use of the control valve. The valve handle turned clockwise will lower the chair, and turned counter-clockwise will raise the chair. The chair will stop at any point along its travel if the valve handle is turned to an intermediate position. Excessive force is not required to turn the valve handle. Instruct all operators of proper use of the control valve prior to operation of the lift.
2. The outer chair arm flips up and back for ease of transfer from a wheelchair to the lift seat. In addition, the stationary arm on the inside of the chair may assist in transferring. Use of the seatbelt is recommended for all users. To facilitate safe loading and unloading of inexperienced users, we recommend that an attendant always be present. Instruct all operators on the proper use of the chair features and the transfer procedure.

3. A lock pin is attached to the top of the cylinder to lock the chair in the fully raised position or rotated 180° over the pool. Push the pin through the piston rod (lower hole) to lock the chair in the fully raised position when the lift is not in use and/or when the water supply is turned off. Use the 180° rotated lock pin hole (upper hole) to lock the chair in place when removing the lift from the anchors.
4. Keep other swimmers and children away from the lift at all times. Remove the lift from poolside when not in use if possible. A cover is available from Spectrum Products® to aid in preventing unauthorized use of the lift.
5. To drain the water from the lift for storage: disconnect the water source, turn the control valve to down, push the chair down, turn the control valve to up, and push the chair back up. Repeating this step is necessary to get all of the water removed. This process will force the water from the cylinder, valve and hoses.

Care and Maintenance

The Swim-Lift® Gallatin is virtually maintenance free since the drive component (water) is self-lubricating. Providing it is installed correctly, the lift will furnish you with many years of trouble-free use.

To ensure safe and dependable use, periodically disengage the deck anchors and lubricate the acme thread nut with a small amount of Vaseline. Also, check that the inside bolt is tight. If it is loose or corroded, replace it immediately. Do not operate the lift until the bolt is replaced.

Maintaining Stainless Steel Products

Stainless steel, when properly maintained, is attractive, strong and durable. Stainless steel is superior to carbon steel in its ability to resist corrosion when it is placed in hostile environments, e.g. indoor aquatic facilities. Stainless steel, however, is not totally stain or rust proof. It is essential that proper fabrication techniques and post fabrication treatment be performed in the manufacturing process, along with periodic product maintenance by the end user, to ensure a beautiful and functional stainless steel product.

It is of utmost importance to properly maintain your stainless steel product! A technique known as passivation can be used to provide a chemically clean surface that will aid in the reformation of the surface oxide layer and can dissolve any free-iron contamination or rust spots on the surface of the stainless steel. Passivation is accomplished by periodic cleaning with SpectraClean™ (part number 202050) whenever the metal is dirty in order to restore its original appearance.

DO:	DON'T:
Clean stainless steel frequently with non-chlorinated water.	Allow stainless steel to come in contact with carbon steel tools.
Field passivate frequently using Spectrum's SpectraClean™ solution.	Clean with chlorinated product or product containing acid (other than prescribed by the product manufacturer).
	Use coarse abrasives like sandpaper.
	Use steel wool to clean.

Troubleshooting

Problem	Cause	Solution
Lift will not move up or down	Unit not level	Check for level and shim accordingly
	Valve Failure	Replace Valve (P/N 27285, 27286)
	Kinked Hose	Un kink hose and recheck
	Air in Cylinder	Run unit 5-7 times up and down while assisting motion
	Dirty Cylinder	Call for assistance
	Worn Top Collar	Replace Top Collar (P/N 27315)
Lift chatters when moving	Air in Cylinder	Run unit 5-7 times up and down while assisting motion
	Dirty Cylinder	Call for assistance
	Worn Top Collar	Replace Top Collar (P/N 27315)
Lift moves up slowly	Low water pressure	Use lift with Booster Pump (P/N 27028-00)
	Worn Seals	Replace Seals (P/N 27245, 27246)
	Valve Failure	Replace Valve (P/N 27285, 27286)
Lift descends with valve in neutral position	Valve Failure	Replace Valve (P/N 27285, 27286)
	Worn Seals	Replace Seals (P/N 27245, 27246)



Spectrum Products® Warranty

Two (2) Year Limited Warranty

What is covered by this warranty?

Spectrum Products® warrants all products it manufactures to be free from defects and materials and factory workmanship to the original buyer. This warranty is contingent to the proper installation, use, care and operation of the equipment for its intended purpose, and does not cover the equipment that has been modified or has been subjected to abusive physical or environmental stresses. Spectrum Products® agrees to repair or replace, at its sole discretion, any product that fails to perform as specified within 24 months after date of the original shipment from the factory unless otherwise noted.

This warranty relates only to defects in material and workmanship and does not include damage or failure resulting from other causes, including, but not limited to acts of God, misuse or abuse, accident or negligence, fire, improper installation or ice damage. This warranty does not apply to fading of materials or to any corrosion of any metallic parts. Damage induced by the improper use of chemicals is not covered by this warranty. In event that products are altered or repaired by anyone without the prior written approval of Spectrum Products®, all warranties are voided.

Powdered Coated Products: This warranty does not cover chipping, flaking, scratches or any other any surface defected due to abuse or mishandling or product. Due to the corrosive environment this warranty does not cover surfaces damaged during handling or installation. Although powder coating on product is designed for long-term use, keeping products outside in the elements, inside in a highly humid environment, excessive washing (including power-washing) or improper maintenance will result in premature corrosion.

Parts: Components of Spectrum Products provided by other manufactures are subject to the original equipment manufactures (OEM) warranty. Examples include but not limited to batteries, actuators, control systems, valves, pumps, etc.

Blankets: Improper storage of the Swimming Pool Blanket System of Spa Blanket may void this warranty. This warranty does not cover damaged caused by chemical action or abrasive material, damage caused by handling or during transportation, or damage arising from misuse, installation or any other cause beyond the manufacture's control.

What will Spectrum do related to the product covered by this warranty?

Provide free of charge (excluding shipping) replacement parts (new or rebuilt at Spectrum's option). This warranty does not cover labor to remove or install equipment and parts. Provide, F.O.B. the factory, new or reconditioned replacement product (Spectrum's opinion).

What is not covered by this warranty?

Damage or loss in transit as indicated by bill of lading, normal wear and tear, chemical damage, discoloration, misuse and damage or loss caused by neglect, abuse, vandalism, modification, improper installation, lack of maintenance or physical damage are not included in this warranty. See Owner's manual for recommendations related to the use and care of the product.

IMPORTANT: TO ENSURE SAFE OPERATION, USERS MUST COMPLY WITH THE PUBLISHED WEIGHT LIMITS ON SEVERAL PRODUCTS SUCH AS SLIDES, LIFTS, CHAIRS, STARTING BLOCKS, STAND AND LADDERS. REFER TO PRODUCT LITERATURE AND MANUALS FOR THESE LIMITATIONS.

How to make a warranty claim:

Contact Spectrum Products®, 7100 Spectrum Lane, Missoula, MT 59808.

Your Rights Under State Law: This warranty gives you specific legal rights, and you may also have other rights, which vary from state to state. Spectrum Products® disclaims all liability for damage during transportation, for incidental, special or consequential damage of whatever nature, for damage due to handling, installation, or improper operation, or for damage caused by circumstances beyond Spectrum Products® control; in no event shall recovery in any kind against Spectrum Products® be greater in amount than the purchase price of the equipment sold by Spectrum Products® that caused alleged damage. Spectrum Products® makes no warranties either expressed or implied, including any warranty of merchantability or fitness for particular purpose, other than these stated. Some states do not allow the exclusion or limitation of incidental or consequential damages, or limitations on how long an implied warranty lasts, so the above exclusions may not apply to you. No representative has authority to change or modify this warranty in any respect.

Gallatin Lifting Assembly

Gallatin 26192 – Standard.....26209 - 12” Water Draft

Box A:

- ___ (1) 13900 Flip Up Footrest w/ HDPE White Footboard
- ___ (1) 13289 Seat Frame Assembly w/ Grips
- ___ (2) 26293 Molded Seat Half Top/Bottom
- ___ (1) Headrest Bar with Gray Spectrum Headrest
- ___ (1) 13890 50' Garden Hose
- ___ (1) Literature
- ___ (1) Cleaning Kit
- ___ (1) Hardware Box

Box B: (Skid)

- ___ (1) Seat Arm
 - ___ (1) Piston Cylinder Assembly w/ Support Column
-

Hardware Pack:

- ___ (2) 200805-03 -1/4" Donut Shims
- ___ (2) 200815-03 -1/2" Donut Shims
- ___ (2) 200825-03 -3/4" Donut Shims
- ___ (2) 200835-03 -1" Donut Shims
- ___ (1) 27236 Pressure Wheel
- ___ (1) 13378 Seat Belt
- ___ (1) 26186 Pressure Wheel Guard
- ___ (1) 23008 Screw Black Plastic Lobe Knob 1/4--20 x 1/2"
- ___ (2) 27302 Valve Handle Knobs
- ___ (1) 27301 Valve Handle Assembly
- ___ (1) 20145 3/16" Collet (2pc. Collar)
- ___ (2) 26235 Acme Bolts 4"
- ___ (1) 550600-03 Spanner Wrench
- ___ (9) 20002 Washer FW 5/16"
- ___ (1) 20061 Nylock Nut 5/16"
- ___ (1) 23006 Screw SHD 3/8 SHLDR 1 1/4 x 5/16"
- ___ (4) 20094 Screw BH 5/16-18 x 1"
- ___ (4) 20026 Screw BH 5/16-18 x 3/4"
- ___ (1) 20013 Screw HC 3/8-16 x 1 1/4"
- ___ (4) 20018 Acorn Nut 3/8"
- ___ (6) 20012 Flat Washers 3/8"
- ___ (4) 20017 Lock Washer 3/8"
- ___ (1) 20004 Nut FHN 3/8"-16
- ___ (4) 20144 Bolt 3/8" x 4 1/2" HX HD Bolt
- ___ (1) 20217 Bolt - HX HD-3/8"-16 x 5.50"
- ___ (8) 20001 Lock Washer 5/16"
- ___ (1) 20011 Nut Nylock 3/8"

Final Inspection:

- ___ Electro-polish finish
- ___ Labels
- ___ Retainer cap installed
- ___ Hoses & fittings
- ___ Rotation is 90 degrees on the deck
- ___ Seat height on deck
- ___ Hole locations for the locking pin
- ___ Box A
- ___ Box B