

FORWARD VISION TABLE - WOOD LEGS

FVT7 SERIES TABLES (OAK OR MAPLE)
ASSEMBLY INSTRUCTIONS

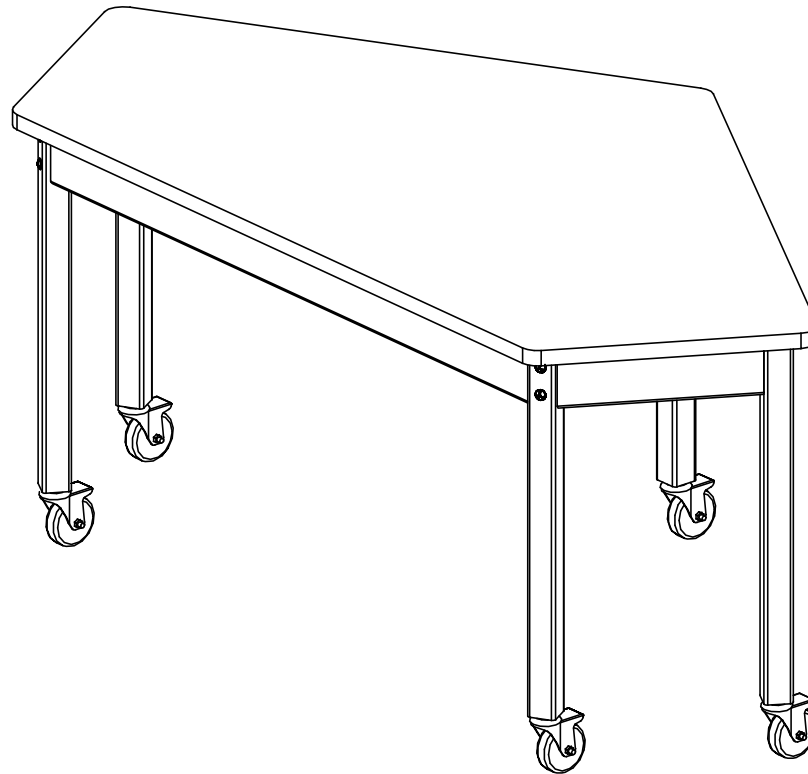

NOTE:

1. MODEL VIEWS MAY NOT REPRESENT EXACT MODEL PURCHASED

ALL DIMENSIONS ARE IN INCHES UNLESS NOTED OTHERWISE		DWN BY:	EMR	DATE DWN:	3/30/21
DECIMALS: $\frac{1}{16}$ = ± .030		APR BY:		DATE APR:	
$\frac{1}{32}$ = ± .020		APR BY:		DATE APR:	
$\frac{1}{64}$ = ± .010		APR BY:		DATE APR:	
ANGLES: = ± 1°		APR BY:		DATE APR:	
CABINET SQUARENESS: = ± .0625		APR BY:		DATE APR:	



CONFIDENTIAL:
ALL DESIGN RIGHTS RESERVED
THE INFORMATION, DATA, DESIGN, AND DRAWINGS EMBODIED IN THIS DOCUMENT AND ALL REPRODUCTIONS THEREOF ARE THE EXCLUSIVE PROPERTY OF DIVERSIFIED WOODCRAFTS, INC.

TITLE:
FORWARD VISION TABLE - WOOD LEGS
ASSEMBLY INSTRUCTIONS

THESE DOCUMENTS ARE SUPPLIED WITH THE UNDERSTANDING THAT THEY WILL NOT BE DISCLOSED TO THIRD PARTIES WITHOUT WRITTEN CONSENT OF DIVERSIFIED WOODCRAFTS, INC. ANY REPRODUCTION IN PART OR WHOLE WITHOUT WRITTEN CONSENT IS SUBJECT TO LEGAL ACTION.

REV.	DESCRIPTION	DATE	NAME	ECN NO.
A	CREATED DRAWING	3/30/21	EMR	-
REVISION LEVEL				

DRAWING NUMBER:	SCALE:	SHEET:	REVISION:
FVT7 SERIES TABLES	NTS	1 OF 8	REV A

TOOLS REQUIRED

1/2" WRENCH
1/2" SOCKET AND TORQUE WRENCH - OPTIONAL
DRILL

ASSEMBLY COMPONENTS

ITEMS INCLUDED	PART #	PART DESCRIPTION	QTY
TOP AND APRON ASSEMBLY	N/A	TOP ASSEMBLY (FACTORY ASSEMBLED)	1
LEGS	VARIES	LEG,(OAK OR MAPLE),(SIZE VARIES)	5
LEG TO TOP BRACKET	256743	BRACKET,ANGLE,90 DEG,4X4X2	3
CARRIAGE BOLT	242886	BOLT,5/16-18X3,CARRIAGE	6
WASHERS	100451	WASHER,5/16 FLAT ZINC PLATED	8
NUTS	100044	NUT,HEX 5/16 - 18 STEEL ZINC	8
CASTERS - DUETTO	255813	CASTER,DUETTO,100MM TWIN WHEEL,BLACK,TOTAL LOCKING DEVICE	5
CASTER - INDUSTRIAL	255721	CASTER,4",TOTAL LOCK STEM CASTER M12 - 1.75MM X 1.75"	5
LOCK WASHER - INDUSTRIAL CASTER	257150	WASHER,1/2" STEEL LOCK WASHER,ZINC	5
GLIDE	255723	GLIDE,NYLON,M12X20MM THREADED STEM,59MM HIGH,45MM NECK, BLACK	5

NOTE:

1. COMPONENTS VARY WITH STYLE OF TABLE PURCHASED.
 - 1.1. HEIGHTS ARE EITHER 30", 34", OR 36".
 - 1.2. TOPS SELECTIONS:
 - 1.2.1. CHEMGUARD, PHENOLIC, SHOP TOP, OR COLORED PLASTIC LAMINATE.
2. ****XX**** INDICATES ITEMS THAT MAY NOT COME WITH UNIT (DEPENDING ON MODEL PURCHASED).

A	CREATED DRAWING	3/30/21	EMR	-
REV.	DESCRIPTION	DATE	NAME	ECN NO.
REVISION LEVEL				

ALL DIMENSIONS ARE IN INCHES UNLESS NOTED OTHERWISE DECIMALS: X = ± .030 XX = ± .020 XXX = ± .010 ANGLES: = ± 1° CABINET SQUARENESS: = ± .0625	DWN BY: EMR	DATE DWN: 3/30/21
	APR BY:	DATE APR:
	APR BY:	DATE APR:

CONFIDENTIAL:
ALL DESIGN RIGHTS RESERVED
THE INFORMATION, DATA, DESIGN, AND DRAWINGS EMBODIED IN THIS DOCUMENT AND ALL REPRODUCTIONS THEREOF ARE THE EXCLUSIVE PROPERTY OF DIVERSIFIED WOODCRAFTS, INC.

THESE DOCUMENTS ARE SUPPLIED WITH THE UNDERSTANDING THAT THEY WILL NOT BE DISCLOSED TO THIRD PARTIES WITHOUT WRITTEN CONSENT OF DIVERSIFIED WOODCRAFTS, INC. ANY REPRODUCTION IN PART OR WHOLE WITHOUT WRITTEN CONSENT IS SUBJECT TO LEGAL ACTION.



TITLE: FORWARD VISION TABLE - WOOD LEGS TOOLS AND ASSEMBLY COMPONENTS

DRAWING NUMBER:	SCALE:	SHEET:	REVISION:
FVT7 SERIES TABLES	NTS	2 OF 8	REV A

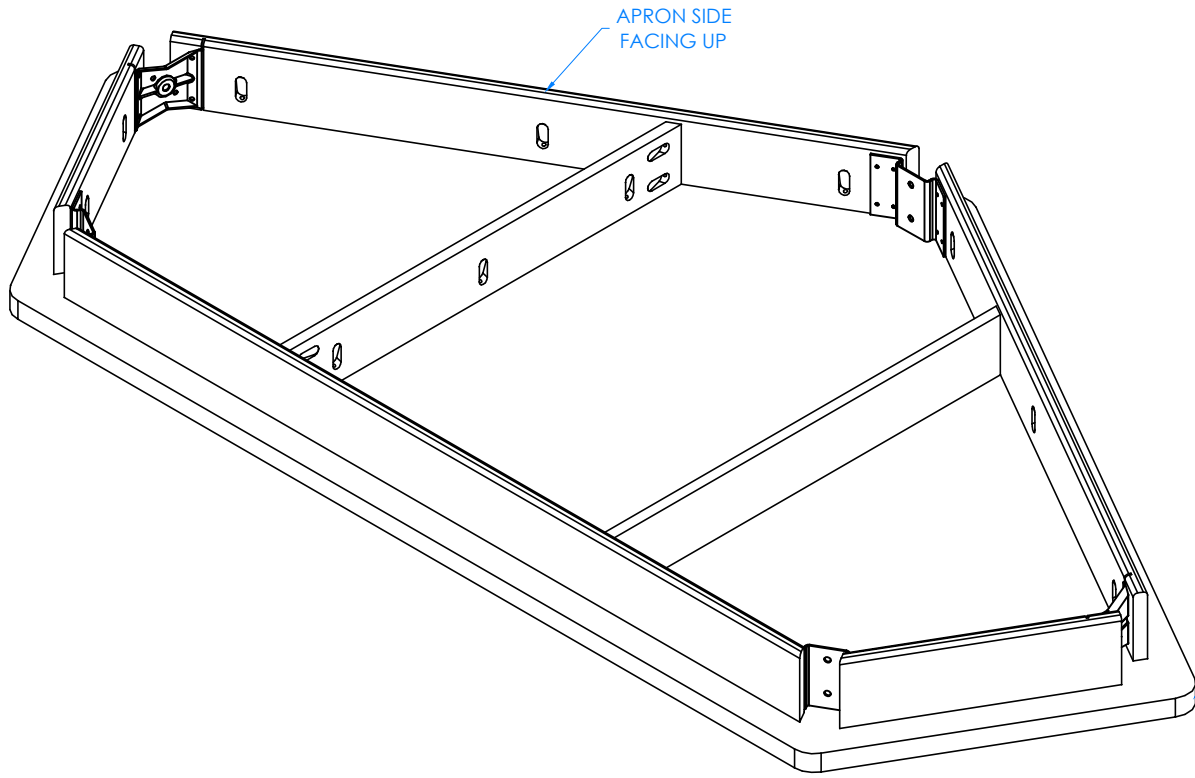

STEP 1:

- LAY TOP ASSEMBLY ON FLOOR WITH APRON SIDE FACING UP.

****NOTE****
BE SURE TOP ASSEMBLY IS ON A CLEAN SURFACE TO PREVENT DAMAGE

NOTE:

- 1.

ALL DIMENSIONS ARE IN INCHES UNLESS NOTED OTHERWISE	DWN BY:	EMR	DATE DWN:	3/30/21
DECIMALS: $\frac{1}{16}$ = ± .000	APR BY:		DATE APR:	
$\frac{1}{32}$ = ± .020	APR BY:		DATE APR:	
$\frac{1}{64}$ = ± .010	APR BY:		DATE APR:	
ANGLES: = ± 1°	APR BY:		DATE APR:	
CABINET SQUARENESS: = ± .0625	APR BY:		DATE APR:	



CONFIDENTIAL:
ALL DESIGN RIGHTS RESERVED
THE INFORMATION, DATA, DESIGN, AND DRAWINGS EMBODIED IN THIS DOCUMENT AND ALL REPRODUCTIONS THEREOF ARE THE EXCLUSIVE PROPERTY OF DIVERSIFIED WOODCRAFTS, INC.

TITLE:
FORWARD VISION TABLE - WOOD LEGS
ASSEMBLY INSTRUCTIONS

THESE DOCUMENTS ARE SUPPLIED WITH THE UNDERSTANDING THAT THEY WILL NOT BE DISCLOSED TO THIRD PARTIES WITHOUT WRITTEN CONSENT OF DIVERSIFIED WOODCRAFTS, INC. ANY REPRODUCTION IN PART OR WHOLE WITHOUT WRITTEN CONSENT IS SUBJECT TO LEGAL ACTION.

DRAWING NUMBER:	SCALE:	SHEET:	REVISION:
FVT7 SERIES TABLES	NTS	3 OF 8	REV A

REV.	DESCRIPTION	DATE	NAME	ECN NO.
A	CREATED DRAWING	3/30/21	EMR	-
REVISION LEVEL				

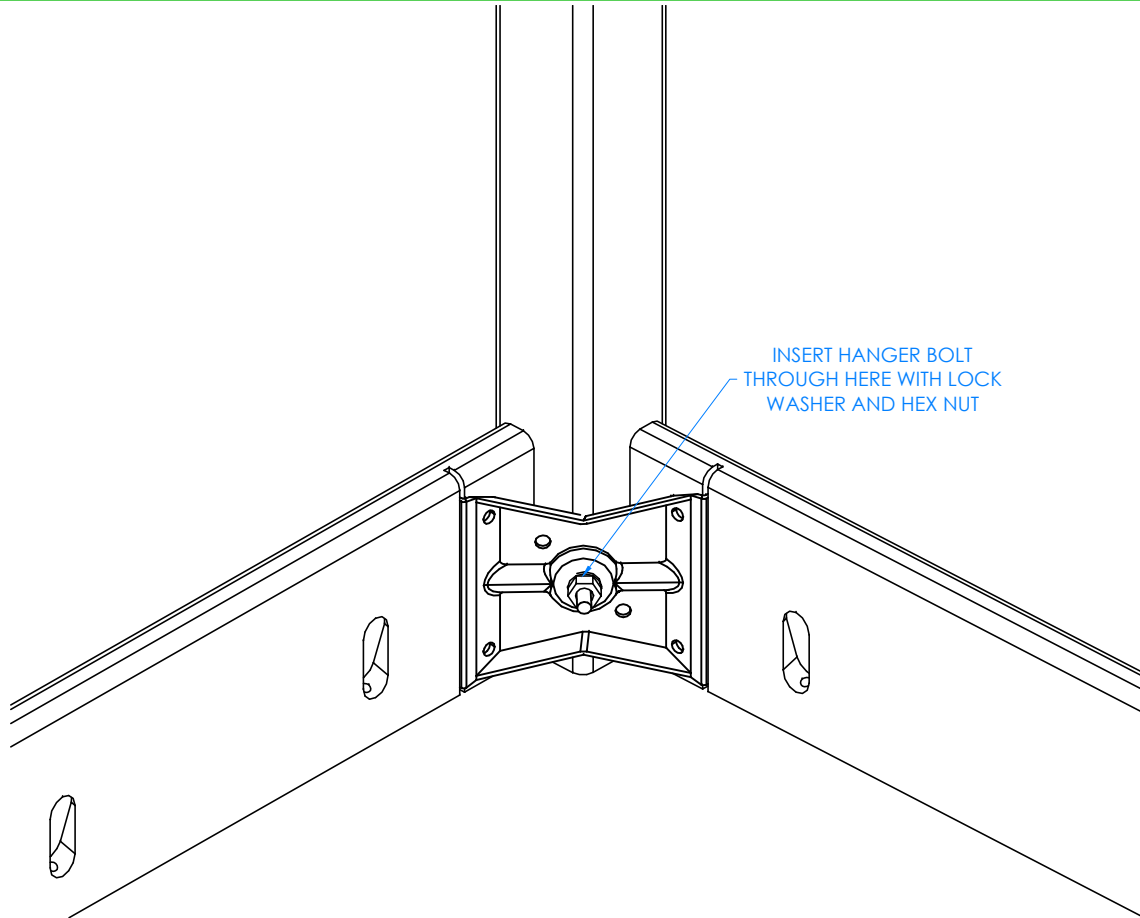

CLOSE UP OF LEG ASSEMBLY

STEP 2:

- TAKE THE (2) LEGS WITH HANGER BOLTS ATTACHED AND INSERT THEM THROUGH THE CORNER BRACKETS WITH LOCK WASHER AND HEX NUT.
- SCREW ON NUT USING 1/2" WRENCH OR 3/8" SOCKET AND TORQUE WRENCH, TO A MINIMUM OF 12FT LBS BUT NOT TO EXCEED 17FT LBS.
- MAKE SURE ALL LEGS ARE STRAIGHT AND ALL NUTS ARE SECURE.

NOTE:

1.

ALL DIMENSIONS ARE IN INCHES UNLESS NOTED OTHERWISE	DWN BY:	EMR	DATE DWN:	3/30/21
DECIMALS: X = ± .000	APR BY:		DATE APR:	
XX = ± .020	APR BY:		DATE APR:	
XXX = ± .010	APR BY:		DATE APR:	
ANGLES: = ± 1°	APR BY:		DATE APR:	
CABINET SQUARENESS: = ± .0625	APR BY:		DATE APR:	

CONFIDENTIAL:
ALL DESIGN RIGHTS RESERVED
THE INFORMATION, DATA, DESIGN, AND DRAWINGS EMBODIED IN THIS DOCUMENT AND ALL REPRODUCTIONS THEREOF ARE THE EXCLUSIVE PROPERTY OF DIVERSIFIED WOODCRAFTS, INC.

THESE DOCUMENTS ARE SUPPLIED WITH THE UNDERSTANDING THAT THEY WILL NOT BE DISCLOSED TO THIRD PARTIES WITHOUT WRITTEN CONSENT OF DIVERSIFIED WOODCRAFTS, INC. ANY REPRODUCTION IN PART OR WHOLE WITHOUT WRITTEN CONSENT IS SUBJECT TO LEGAL ACTION.



TITLE:
FORWARD VISION TABLE - WOOD LEGS
ASSEMBLY INSTRUCTIONS

REV.	DESCRIPTION	DATE	NAME	ECN NO.
A	CREATED DRAWING	3/30/21	EMR	-
REVISION LEVEL				

DRAWING NUMBER:	SCALE:	SHEET:	REVISION:
FVT7 SERIES TABLES	NTS	4 OF 8	REV A

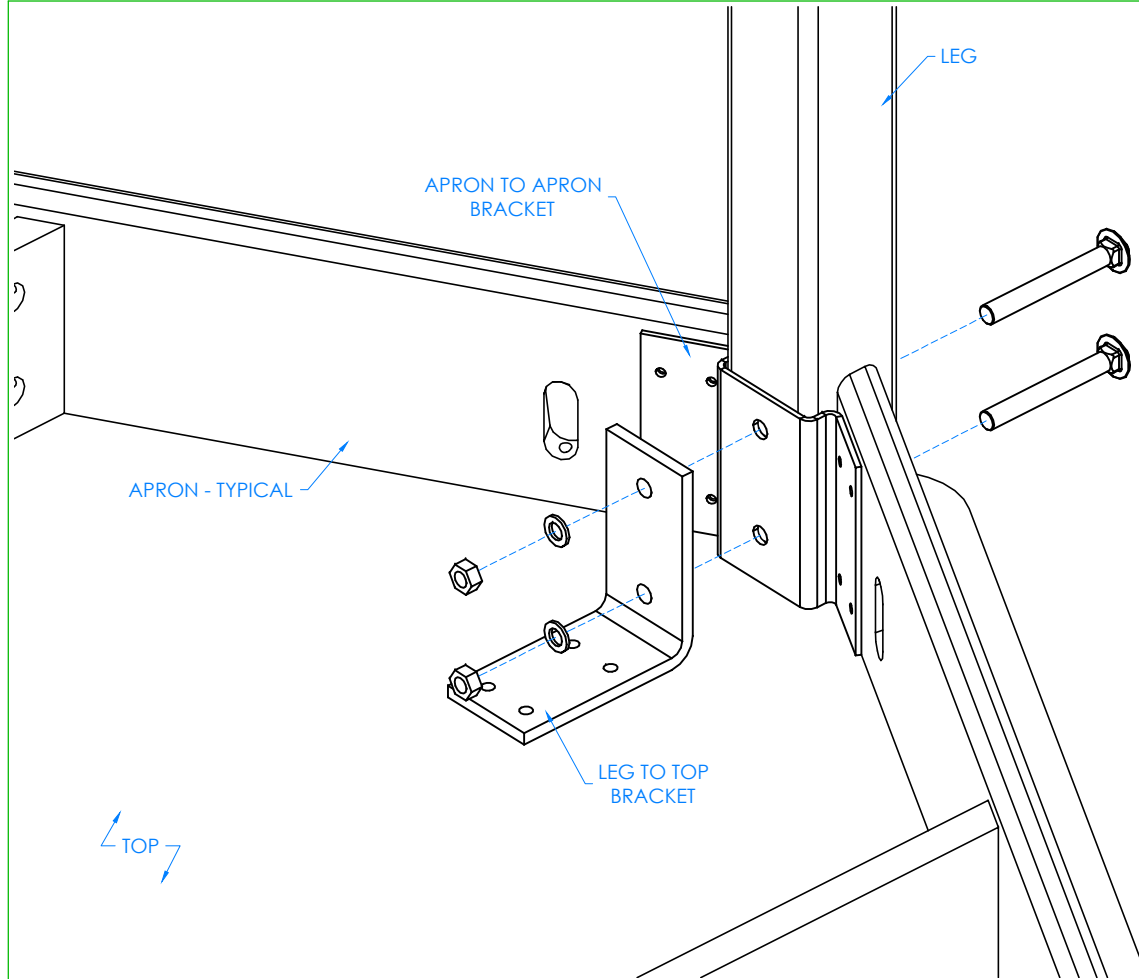

STEP 3:

- POSITION THE OTHER (3) LEGS (WITHOUT HANGER BOLTS) IN BETWEEN THE APRONS.
- MAKE SURE THROUGH HOLES ON LEGS LINE UP WITH THROUGH HOLES ON APRON TO APRON BRACKETS.
- INSERT CARRIAGE BOLTS THROUGH LEGS INTO APRON TO APRON BRACKET.
- SLIDE LEG TO TOP BRACKET OVER BOLTS.
- APPLY LOCK WASHERS AND HEX NUTS.
- SCREW ON NUTS USING A 1/2" WRENCH OR 1/2" SOCKET AND TORQUE WRENCH, TO A MINIMUM OF 12FT LBS BUT NOT TO EXCEED 17FT LBS.
- MAKE SURE ALL LEGS ARE STRAIGHT AND ALL NUTS ARE SECURE.

NOTE:

1.

CLOSE UP OF LEG AND BRACKET ASSEMBLY

ALL DIMENSIONS ARE IN INCHES UNLESS NOTED OTHERWISE		DWN BY:	EMR	DATE DWN:	3/30/21
DECIMALS: .X = ± .000		APR BY:		DATE APR:	
.XX = ± .020		APR BY:		DATE APR:	
.XXX = ± .010		APR BY:		DATE APR:	
ANGLES: = ± 1°0'		APR BY:		DATE APR:	
CABINET SQUARENESS: = ± .0625		APR BY:		DATE APR:	

CONFIDENTIAL:
 ALL DESIGN RIGHTS RESERVED
 THE INFORMATION, DATA, DESIGN, AND DRAWINGS EMBODIED IN THIS DOCUMENT AND ALL REPRODUCTIONS THEREOF ARE THE EXCLUSIVE PROPERTY OF DIVERSIFIED WOODCRAFTS, INC.

THESE DOCUMENTS ARE SUPPLIED WITH THE UNDERSTANDING THAT THEY WILL NOT BE DISCLOSED TO THIRD PARTIES WITHOUT WRITTEN CONSENT OF DIVERSIFIED WOODCRAFTS, INC. ANY REPRODUCTION IN PART OR WHOLE WITHOUT WRITTEN CONSENT IS SUBJECT TO LEGAL ACTION.



TITLE:
 FORWARD VISION TABLE - WOOD LEGS
 ASSEMBLY INSTRUCTIONS

REV.	DESCRIPTION	DATE	NAME	ECN NO.
A	CREATED DRAWING	3/30/21	EMR	-

REVISION LEVEL

DRAWING NUMBER:

FVT7 SERIES TABLES

SCALE:

NTS

SHEET:

5 OF 8

REVISION:

REV A

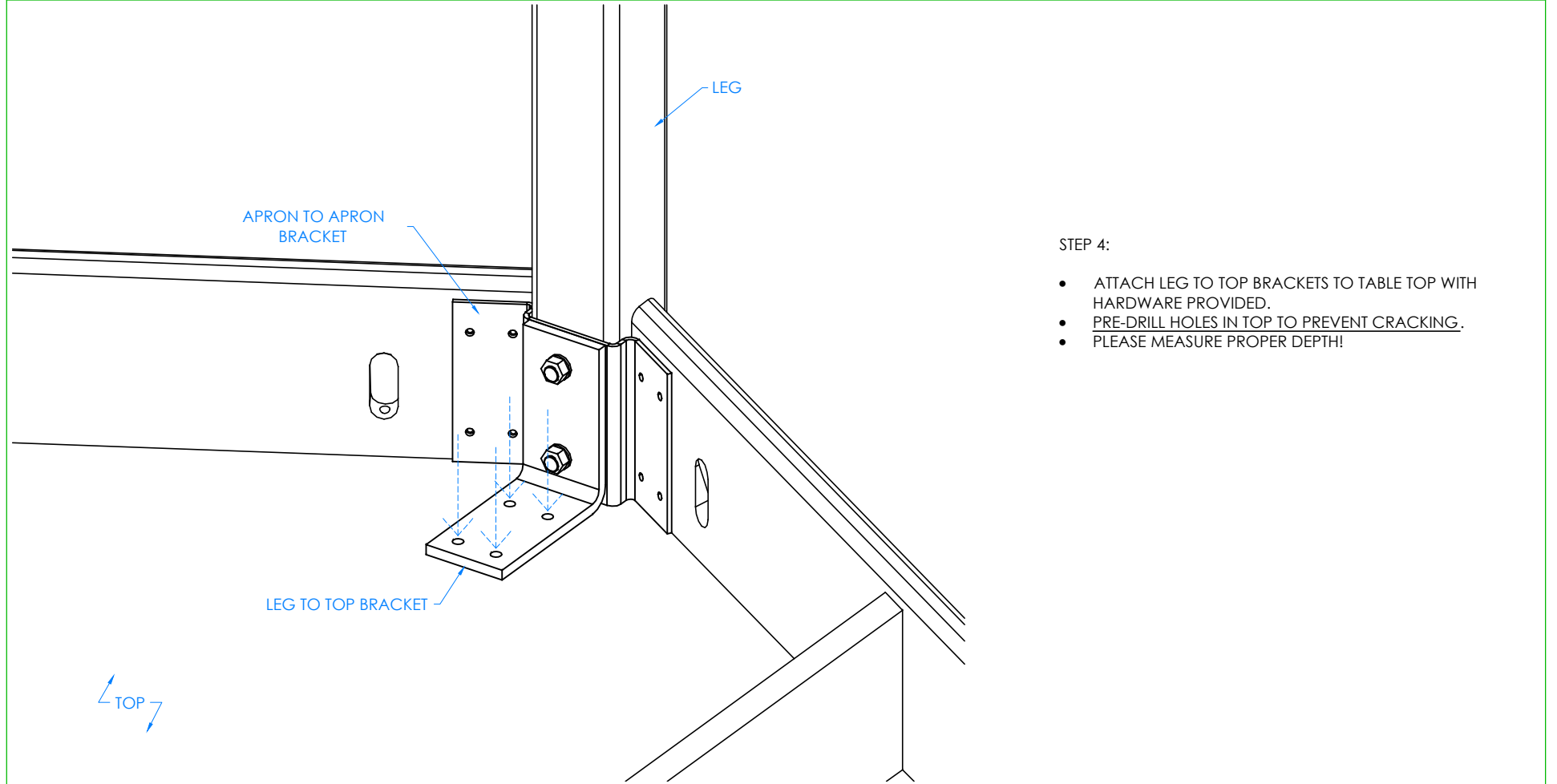

- STEP 4:
- ATTACH LEG TO TOP BRACKETS TO TABLE TOP WITH HARDWARE PROVIDED.
 - PRE-DRILL HOLES IN TOP TO PREVENT CRACKING.
 - PLEASE MEASURE PROPER DEPTH!

NOTE:
1.

CLOSE UP OF LEG AND BRACKET ASSEMBLY

REV.	DESCRIPTION	DATE	NAME	ECN NO.
A	CREATED DRAWING	3/30/21	EMR	-
REVISION LEVEL				

ALL DIMENSIONS ARE IN INCHES UNLESS NOTED OTHERWISE
 DECIMALS: X = ± .000
 XX = ± .020
 XXX = ± .010
 ANGLES: = ± 1°
 CABINET SQUARENESS: = ± .0625

DWN BY:	EMR	DATE DWN:	3/30/21
APR BY:		DATE APR:	
APR BY:		DATE APR:	

CONFIDENTIAL:
 ALL DESIGN RIGHTS RESERVED
 THE INFORMATION, DATA, DESIGN, AND DRAWINGS EMBODIED IN THIS DOCUMENT AND ALL REPRODUCTIONS THEREOF ARE THE EXCLUSIVE PROPERTY OF DIVERSIFIED WOODCRAFTS, INC.

THESE DOCUMENTS ARE SUPPLIED WITH THE UNDERSTANDING THAT THEY WILL NOT BE DISCLOSED TO THIRD PARTIES WITHOUT WRITTEN CONSENT OF DIVERSIFIED WOODCRAFTS, INC. ANY REPRODUCTION IN PART OR WHOLE WITHOUT WRITTEN CONSENT IS SUBJECT TO LEGAL ACTION.

TITLE:
 FORWARD VISION TABLE - WOOD LEGS
 ASSEMBLY INSTRUCTIONS

DRAWING NUMBER:	SCALE:	SHEET:	REVISION:
FVT7 SERIES TABLES	NTS	6 OF 8	REV A

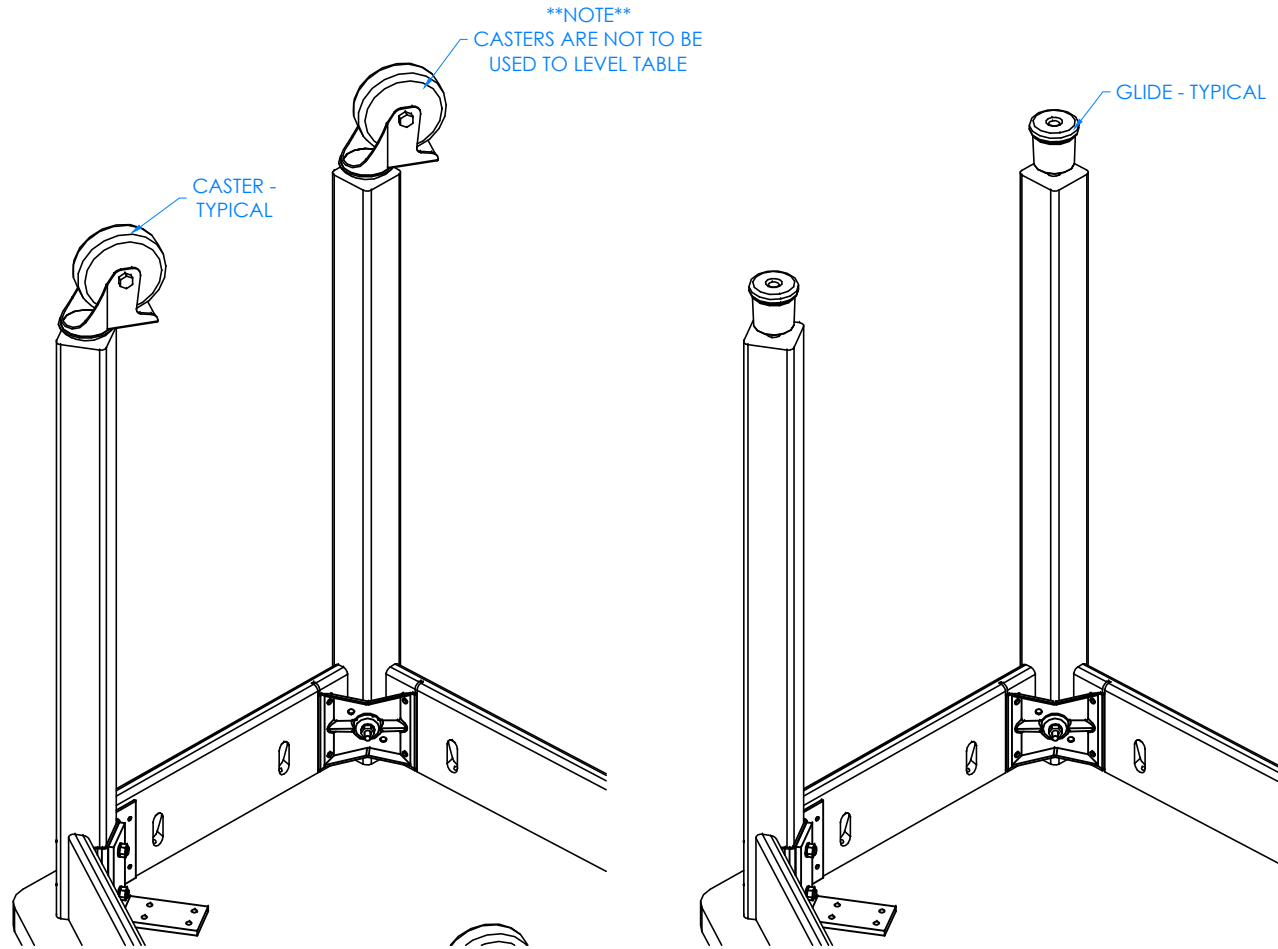

STEP 5:

- ATTACH EITHER CASTERS OR GLIDES TO THE BOTTOM OF EACH LEG INSERT.
- MAKE SURE CASTERS ARE THREADED ALL THE WAY AND ARE FULLY TIGHTENED.
- IF YOU HAVE "INDUSTRIAL" CASTERS, MAKE SURE YOU APPLY LOCK WASHER (NOT SHOWN) TO CASTERS BEFORE ATTACHING TO LEGS!
- IF YOU HAVE "DUETTO" CASTERS (NOT SHOWN), TAKE WHEEL OFF FROM STEM AND TIGHTEN CASTER FULLY TO EACH LEG! PUT WHEEL BACK ON ONCE FINISHED.
- CASTERS ARE NOT TO BE USED TO LEVEL TABLE!

NOTE:

1.

ALL DIMENSIONS ARE IN INCHES UNLESS NOTED OTHERWISE	DWN BY:	EMR	DATE DWN:	3/30/21
DECIMALS: X = ± .030	APR BY:		DATE APR:	
XX = ± .020	APR BY:		DATE APR:	
XXX = ± .010	APR BY:		DATE APR:	
ANGLES: = ± 1°	APR BY:		DATE APR:	
CABINET SQUARENESS: = ± .0625	APR BY:		DATE APR:	

CONFIDENTIAL:
ALL DESIGN RIGHTS RESERVED
THE INFORMATION, DATA, DESIGN, AND DRAWINGS EMBODIED IN THIS DOCUMENT AND ALL REPRODUCTIONS THEREOF ARE THE EXCLUSIVE PROPERTY OF DIVERSIFIED WOODCRAFTS, INC.

THESE DOCUMENTS ARE SUPPLIED WITH THE UNDERSTANDING THAT THEY WILL NOT BE DISCLOSED TO THIRD PARTIES WITHOUT WRITTEN CONSENT OF DIVERSIFIED WOODCRAFTS, INC. ANY REPRODUCTION IN PART OR WHOLE WITHOUT WRITTEN CONSENT IS SUBJECT TO LEGAL ACTION.



TITLE:
FORWARD VISION TABLE - WOOD LEGS
ASSEMBLY INSTRUCTIONS

A	CREATED DRAWING	3/30/21	EMR	-
REV.	DESCRIPTION	DATE	NAME	ECN NO.

REVISION LEVEL

DRAWING NUMBER:	SCALE:	SHEET:	REVISION:
FVT7 SERIES TABLES	NTS	7 OF 8	REV A

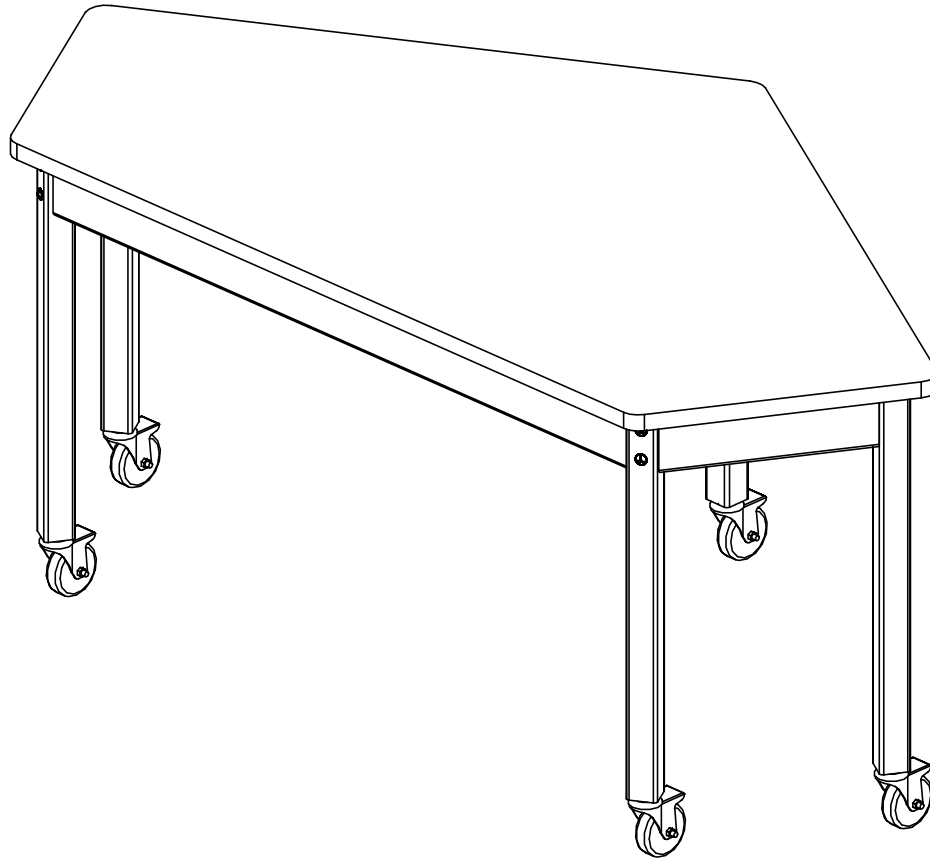

STEP 6:

- WITH HELP FROM ANOTHER PERSON, TURN TABLE OVER ONTO CASTERS/GLIDES.
- SET IN DESIRED LOCATION.

NOTE:

1.

COMPLETE UNIT SHOWN

ALL DIMENSIONS ARE IN INCHES UNLESS NOTED OTHERWISE	DWN BY:	EMR	DATE DWN:	3/30/21
DECIMALS: $\times = \pm .000$	APR BY:		DATE APR:	
$_{XX} = \pm .020$	APR BY:		DATE APR:	
$_{XXX} = \pm .010$	APR BY:		DATE APR:	
ANGLES: $= \pm 1^{\circ}0'$	APR BY:		DATE APR:	
CABINET SQUARENESS: $= \pm .0625$	APR BY:		DATE APR:	



CONFIDENTIAL:
 ALL DESIGN RIGHTS RESERVED
 THE INFORMATION, DATA, DESIGN, AND DRAWINGS EMBODIED IN THIS DOCUMENT AND ALL REPRODUCTIONS THEREOF ARE THE EXCLUSIVE PROPERTY OF DIVERSIFIED WOODCRAFTS, INC.

TITLE:
 FORWARD VISION TABLE - WOOD LEGS
 ASSEMBLY INSTRUCTIONS

THESE DOCUMENTS ARE SUPPLIED WITH THE UNDERSTANDING THAT THEY WILL NOT BE DISCLOSED TO THIRD PARTIES WITHOUT WRITTEN CONSENT OF DIVERSIFIED WOODCRAFTS, INC. ANY REPRODUCTION IN PART OR WHOLE WITHOUT WRITTEN CONSENT IS SUBJECT TO LEGAL ACTION.

DRAWING NUMBER:	SCALE:	SHEET:	REVISION:
FVT7 SERIES TABLES	NTS	8 OF 8	REV A

REV.	DESCRIPTION	DATE	NAME	ECN NO.
A	CREATED DRAWING	3/30/21	EMR	-
REVISION LEVEL				