



eFOLDi

Flight Safety Certificate

eFOLDi mobility scooter



Model: Explorer (MK1.5)



eFOLDi



This battery conforms to the IATA (International Air Transport Association) requirements and specifications for transport by mobility impaired passengers on Passenger Aircraft as set out in Section 2.3.2.4. of the IATA Dangerous Goods Regulations (edition 63).

NB: Individual Airlines/Operators and/or Nations may impose more rigorous restrictions than those outlined under the international minimums referred to above.

Battery information:

eFOLDi FarReach, Lithium-Ion, Dry, Non spillable, 24VDC, 12ah, 288Wh

Dimensions: 19.5x8.5x11cm

Weight:1.8kg/each

Key lock: Yes

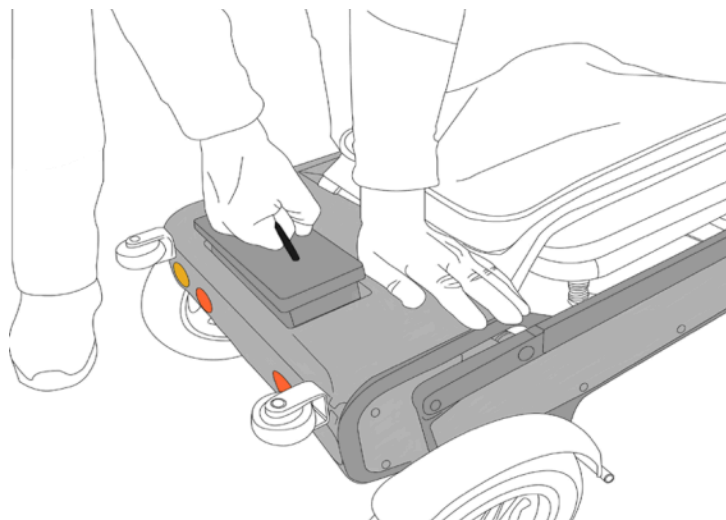

Lift the battery from scooter after unlocking it using the key



eFOLDi

Scooter weight: 17kg without battery/19kg with battery

Scooter fully folded size: 66x56x40cm (26x22x15.6inch)

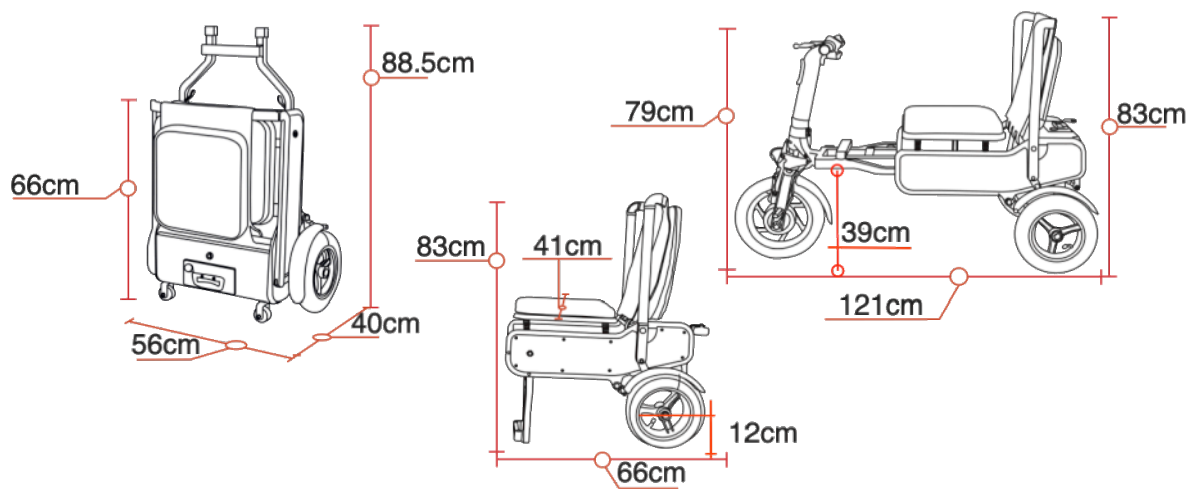

Dimensions