

SPA LIFT ELITE

U.S. PATENT NO. D507,769 S

PRODUCT WEIGHT: 185lbs [84kg]
 MAX WEIGHT CAPACITY: 300lbs [136kg]
 MIN ANCHOR SETBACK: 10"
 MIN WALL HEIGHT: 21"
 WALL THICKNESS @ MIN HEIGHT: 18"
 MAX WALL HEIGHT: 68"
 WALL THICKNESS @ MAX HEIGHT: 15"
 VERTICAL TRAVEL DISTANCE: 58 7/8"

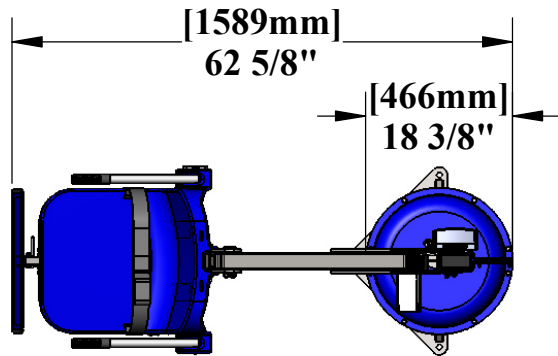
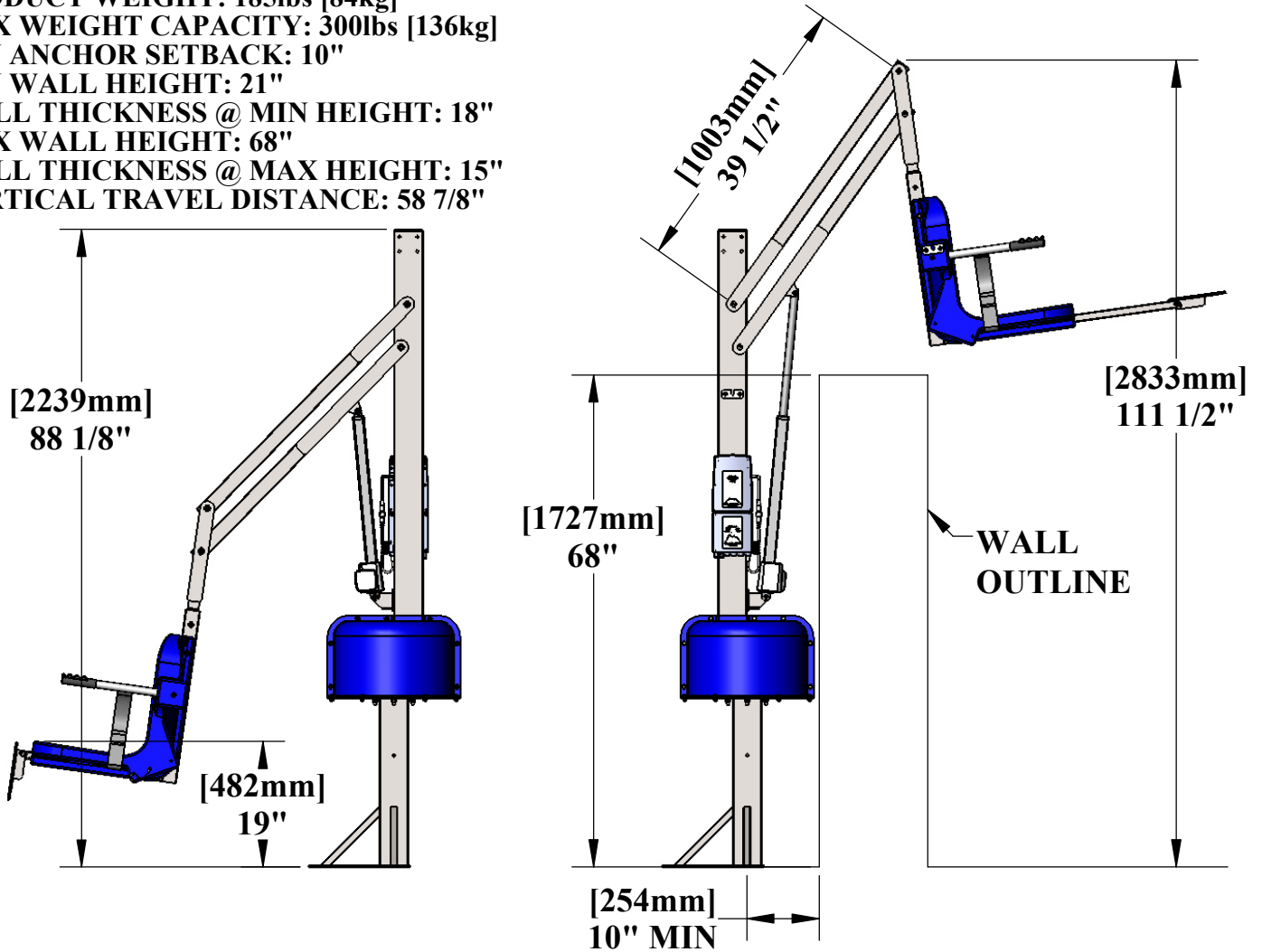

LOADING POSITION

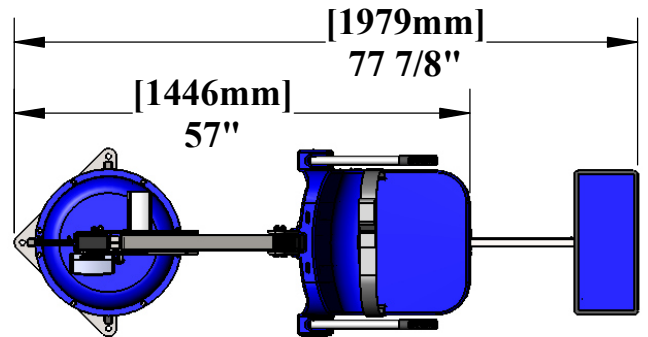

ABOVE WALL



NOTE:
 *SPECIFICATIONS ARE SUBJECT TO CHANGE WITHOUT NOTICE

PRODUCT: SPA LIFT ELITE	
PART #: F-006SLE	
SCALE: 1:24	DATE: 2/15/2017
DRAWN BY: KR	REVISION: A