



## ENTRAPMENT PREVENTION INFORMATION for APBRs

**NOTE:** The U.S. Consumer Product Safety Commission (CPSC) and the Food & Drug Administration (FDA) state that these products, generally known as bed rails, are classified as Adult Portable Bed Rails (APBRs).

It is known that there is a risk of Entrapment when Adult Portable Bed Rails (APBRs), are used. Hartmobility Inc. is committed to inform our customers and users about what Entrapment is, where the risks of Entrapment are, and to provide this Entrapment Prevention Information.

Hartmobility Inc.'s R & D department, Design Engineers and Product Quality Control Department all work continuously together to minimize and mitigate these risks. We employ Research facility staff and Consultants where appropriate.

### **GENERAL NOTES:**

Entrapment risk exists whenever a user of an APBR can have their head, neck, chest, or other body part trapped in the space between the bed and/or mattress and the APBR. Before installing or using an APBR, it is important to consider carefully who will be using the APBR. Standards outlined in ASTM F3186-17, the CPSC, and the FDA describe users who are particularly at risk of entrapment, suffocation and strangulation as, "People with Alzheimer's disease, dementia, or other neurological conditions, or those who are sedated, confused, or frail." Caregivers and installers of APBRs must understand and be aware of entrapment risks and take full responsibility for the correct installation and use of APBRs.

The ASTM F3186-17 Standard mandates four Entrapment Zones: 1, 2, 3 & 4. These are the Zones that APBRs must to be tested for, with pass requirements for each of these Zones. The FDA has identified seven Entrapment Zones. Zones 1, 2, 3 & 4 are the same Zones as the in the ASTM F3186-17 Standard. Zones 5, 6 & 7 have been added by the FDA. All seven Entrapment Zones are shown in Illustration 1 below.  
<https://www.fda.gov/media/71460/download> (Page 13)

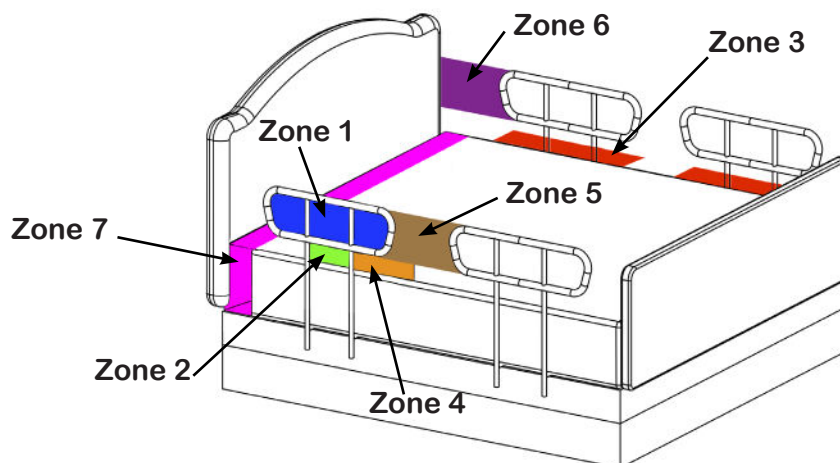

### **ZONES 1, 2, 3 & 4**

#### **Zone 1: Within The Rail Of The APBR.**

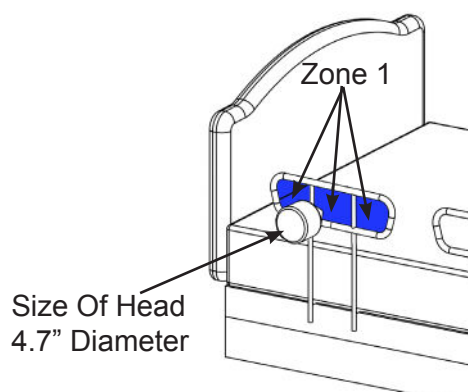

- Any open space or gap in the APBR larger than 4.7 inches (120mm) diameter.
- The ASTM F3186-17 Standard states that any gaps or spaces through the APBR must be less than 4.7 inches (120mm) diameter, which is considered the size of a small human head.
- *NOTE: Hartmobility Inc. APBRs do not have any spaces or gaps larger than 4.7 inches (120mm) diameter.*

#### **Zone 2: Under The Rail, Between The Rail Supports Or Next To A Single Rail Support Of The APBR.**

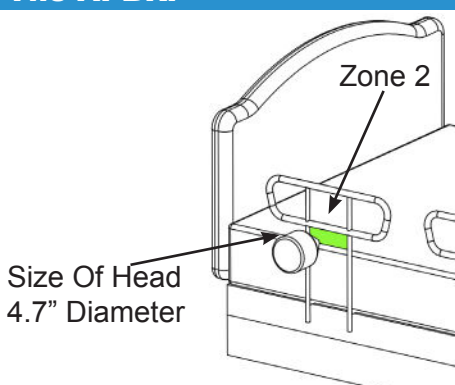

- Any space or gap under the APBR larger than 4.7 inches (120mm) diameter.
- *NOTE: There are no spaces or gaps larger than 4.7 inches (120mm) under the rails, between the rails or next to a single rail support in any Hartmobility Inc. APBRs.*

### Zone 3: Between The Rails Of The APBR And The Mattress.

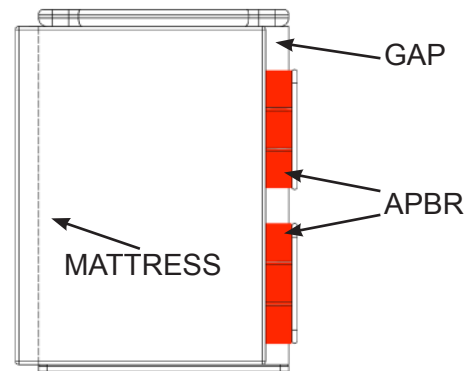
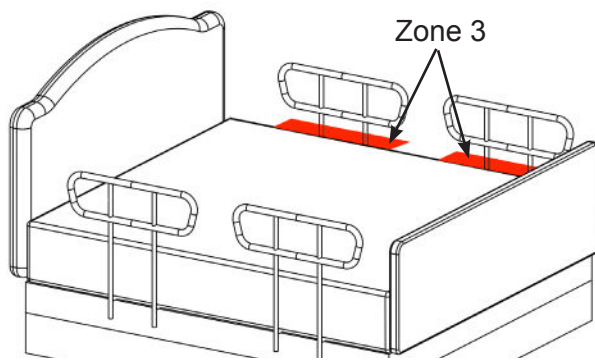

- No gap between the edge of the mattress and the inside of the APBR is allowed.

### Zone 4: Under The Rail At The Ends Of Rail Of The APBR And The Mattress.

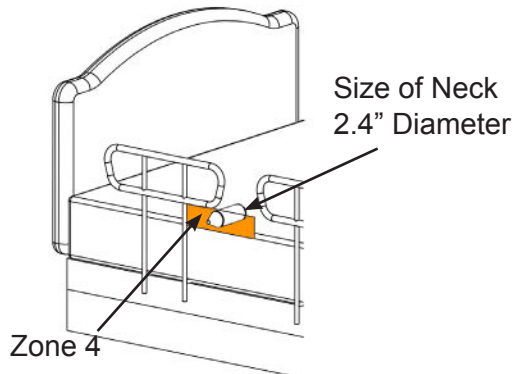

- Gaps under the end of the APBR and the mattress can entrap a person's neck. If there are any gaps the gap must be less than 2.4 inches (60mm) which is a small user's neck.
- *NOTE: Hartmobility Inc. APBRs do not have an overhang for a user's neck to get trapped under.*

### ZONES 5, 6 & 7

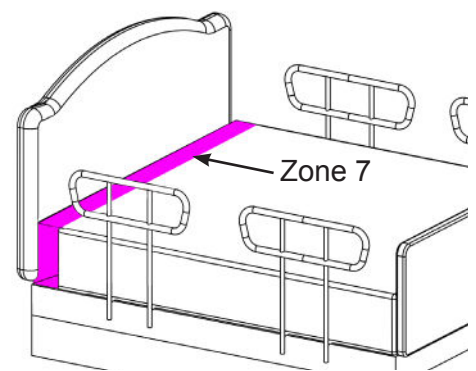
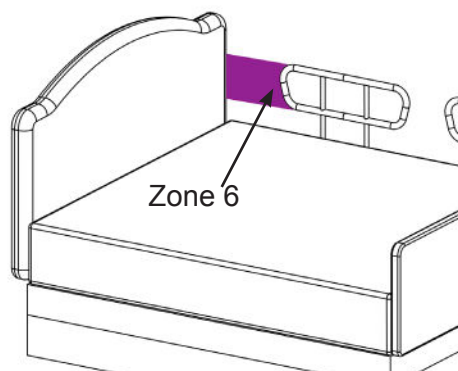
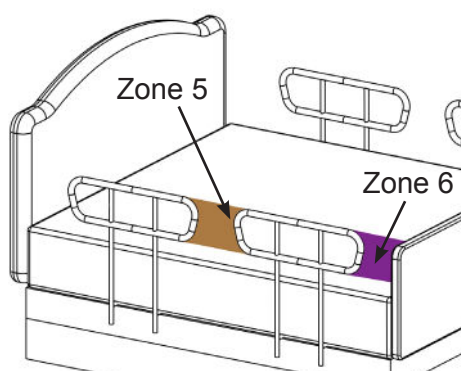

### Zone 5: Between Two APBRs On The Same Side Of The Bed.

- The gaps or spaces between two APBRs can entrap the user by the head, neck, chest or other body parts.
- *Hartmobility does NOT recommend the use of two APBR's on the same side of the bed.*

### Zone 6: Between The End Of The Rail Of The APBR And The Side Edge Of The Head Or Foot Board.

- The gap between the head board or foot board of a bed can entrap.
- The ASTM F3186-17 Standard states that any gaps or spaces between the head board and/or foot board and the end of the APBR must be greater than 12.5 inches (320mm).

### Zone 7: Between The Head Or Foot Board And The End Of The Mattress.

- Any gap or space between the inside surface of the head board or foot board and the end of the mattress can increase the risk of head entrapment.

For more copies of this Entrapment Prevention Information document, or any other Hartmobility Inc. document, please visit [www.hartmobility.com/EntrapmentPreventionInformation](http://www.hartmobility.com/EntrapmentPreventionInformation) or call our Customer Support staff at 1-800-998-0774 ext. 3