

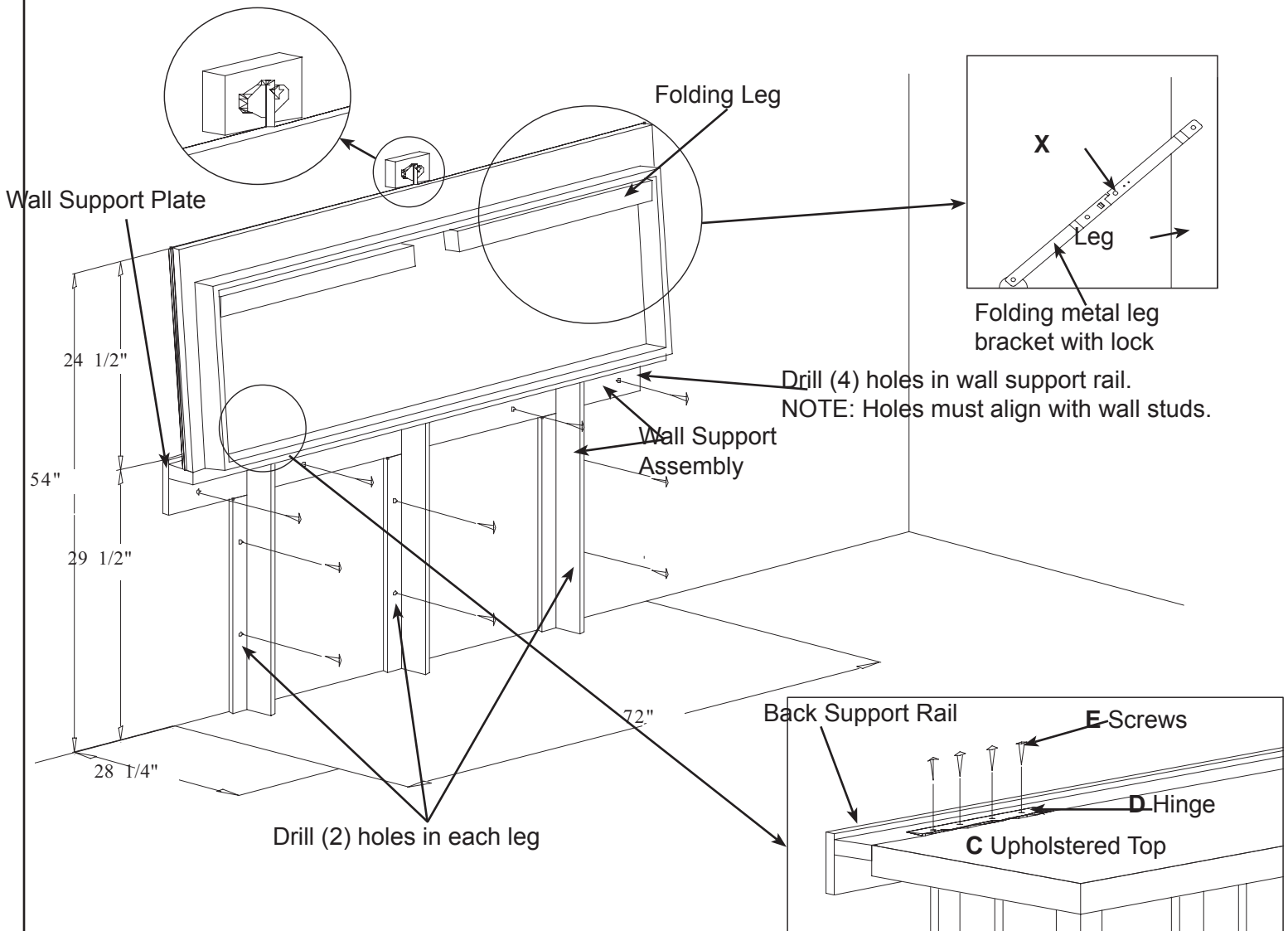

HAUSMANN INDUSTRIES, INC.

Installation/Operation Instructions

Model 4075 - Wall Folding Treatment/Changing Table



Installation:

1. Mount wall support assembly to wall allowing it to sit on the floor, using fasteners (not supplied by Hausmann Industries, Inc.). **NOTE:** Make sure the wall fasteners are fastened into as many wall studs as possible.
2. Position the bottom of the slide bolt lock 24 1/2" above the back support rail and mount using fasteners (not supplied by Hausmann Industries, Inc.).
NOTE: Make sure that the slide bolt block is fastened into a stud.
3. Lay top upside down on smooth surface, fold open the legs on the platform and raise the table to set the platform hinges (D) (two) on the back support rail. Attach platform hinges to back support rail with the 8 screws (E) provided using the pre-drilled holes as guides.
4. Slowly lift the table to a vertical position. While supporting table, slide down bolt to lock table in vertical position.
5. Push in locking button (X) on folding leg bracket, while pushing in hinge towards inside corner of table until disengaged. Now swing the leg towards interior of table, until fully closed. Repeat on second leg.

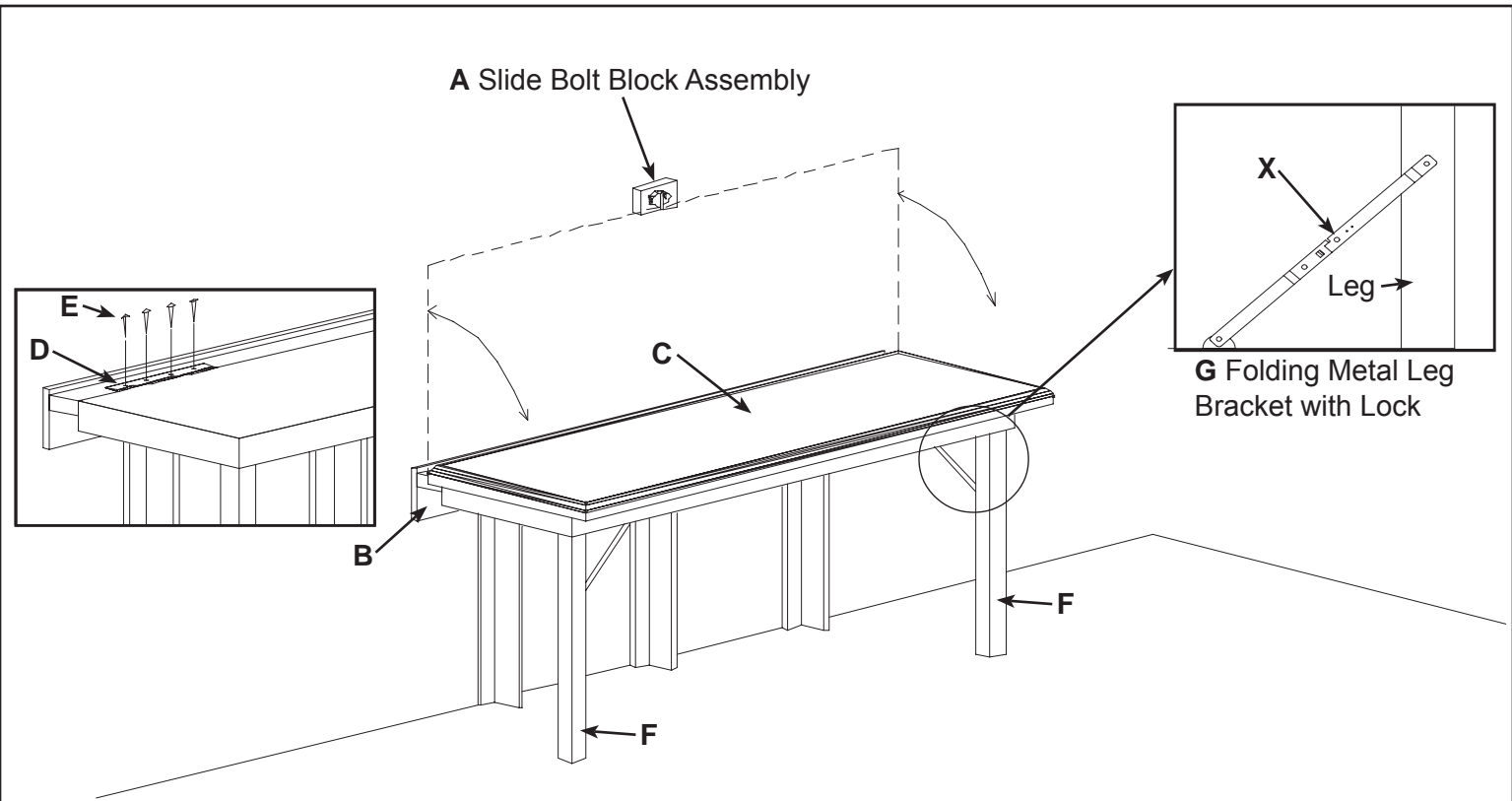

Operation:

1. To fold the table:

- Slowly fold the top against the wall and lock slide bolt to secure top to wall.
- Press locking button (X) to disengage leg bracket. Slowly swing leg towards inside of table. Repeat with second leg.

2. To unfold table:

- Pullout legs. Be sure that the legs lock into place when fully extended by pulling center of leg bracket toward you.
- While supporting table top, open slide bolt so it is in a position that will allow the table to fold down. Carefully lower the table with two hands from the wall to the floor.

CAUTION: Maintain control over the table during complete unfolding operation. Do not allow the table to drop down unattended.

Parts List:

PART	P	ART#	QTY	DESCRIPTION
A		4075-001	1	Slide bolt block assembly
B		4075-002	1	Wall Support Assembly
C		4075-003	1	Upholstered top
D		4075-004	2	Table Top Hinges
E		4075-005	8	Screws, 3/4", #8, Truss, Phil.
F		4075-006	2	Legs (3 Legs for 1422)
G		4075-007	2	Folding Leg Brckts (3 for 1422)



Please join Hausmann's effort to reduce paper use and keep the planet green by using our paperless Warranty Registration form. Visit www.hausmann.com and click on Warranty Registration. If you do not have web access or prefer the form be mailed or faxed to you, please call Hausmann Customer Service.
As of January 1, 2010, we will no longer include the paper based forms, please visit the online link to fill in your Warranty Form.