

# M-RAIL

Ergonomic 'one-size-fits-all' Bedside Assistive Handrail

Hartmobility™  
Premium HOME HEALTHCARE

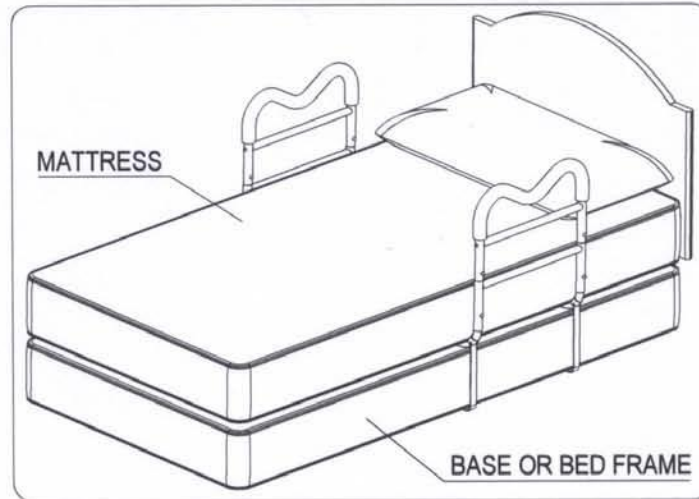

## Caution and Warnings

- Please read these Instructions carefully before installing and using M-RAIL. Please read Caution and Warnings labels attached to the M-RAIL product.
- The M-RAIL is an Assistive Handrail for beds. It is to assist individuals in moving or sitting up in bed, helping with balance to get in and out of bed and to assist with balance when standing beside the bed or during transfers.
- M-RAIL is not intended to support the full weight of an individual and is suitable for people weighing up to 300 Lbs.
- Entrapment between a mattress and an assistive handrail device can be serious and potentially life-threatening. Entrapment can occur when there is a gap between the side of the mattress and the assistive handrail, or a gap greater than 3 inches or 75 mm between the top of the mattress and the assistive handrail cross bar(s). It is possible for an individual's head, arm(s), leg(s) or body to become wedged between the side of the mattress and the assistive handrail or the top of the mattress and the assistive handrail cross bars. The mattress must be tight against the assistive handrail with no gaps and checked at least daily for gaps.
- Extra safety measures and precautions should be used for high-risk patients.
- Read "A Guide to Bed Safety" ([www.fda.gov/cdrh/beds/bed\\_brochure1.html](http://www.fda.gov/cdrh/beds/bed_brochure1.html)) by the Hospital Bed Safety Workgroup.
- For added safety, Hart Mobility recommends installing 2 M-Rails – one for each side of the bed.
- **M-RAIL IT IS NOT TO BE USED AS A RESTRAINT and NOT TO BE USED TO PREVENT USERS FROM FALLING OUT OF BED.** For these functions you must use a correctly designed Bed Rail.

# M-RAIL Installation Instructions

## Assembling the M-RAIL

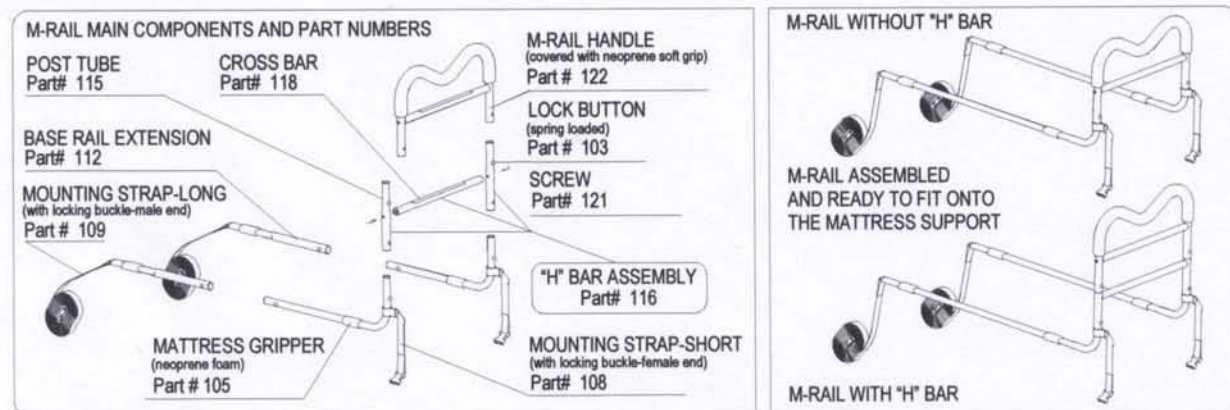

1. Open the end of the carton and slide out the M-RAIL components.
2. Remove the plastic covering and dispose safely away from children.
3. If you have a regular thickness mattress: place the M-RAIL handle only over the posts of the base rails. You will not need Items: 115, 118 & 121. Assemble M-RAIL handle with the Base bars and make sure all the spring buttons are securely locked in place. **IMPORTANT:** the space between the lower cross bar and the mattress should not exceed 3 inches.
4. If you have a thicker mattress, you may choose to add the "H" bar assembly to the M-RAIL handle assembly. The "H" Bar assembly consists of Items: 115 (2), 118 & 121 (2). Assemble M-RAIL handle and the "H" bar assembly with the Base bars and make sure all the spring buttons are securely locked in place. **IMPORTANT:** the space between the lower cross bar and the mattress should not exceed 3 inches. **INSTALLATION QUICK TIP:** If you are experiencing difficulty assembling the "H" Bar assembly to the M-RAIL Handle - loosen the screws on the "H" Bar assembly -Part #116, assemble the "M" Rail Handle and the "H" Bar together and re-tighten the screws. Use an Allen key (provided).

## Fitting the M-RAIL on the Bed

To install the M-RAIL on the bed, complete the following steps:

1. Slide the assembled base rails between the mattress and the base or bed frame support.
2. Lie on the bed and position the M-RAIL at the most comfortable gripping distance.
3. Undo elastic bands on the nylon webbing and run the webbing between the mattress and base or bed frame support and return under the base or bed frame bringing it back to the handle side.
4. Clip the locking buckles together and pull each strap end to secure tightly. (Please see Cautions and Warnings)
5. Ensure the 2 webbing straps are straight and parallel and are pulled tightly, secured against the base or bed frame edge.
6. Tuck the excess webbing under the mattress support or cut it off to avoid any tripping hazards.

