

PC024
TRI-LOCK ROTATING SHAFT

PC024 TRI-LOCK ROTATING SHAFT IS MADE OF PRECISION-MACHINED ALUMINUM WITH A HARD-ANODIZED FINISH.

PERIODIC LUBRICATION OF THE ROTATING HEAD WITH TEFLON GREASE WILL PRESERVE ITS SMOOTH ACTION

description

TRI-LOCK ROTATING SHAFT & MIDLINE ARM SPECS

drawing no.	date originated	drawn by	rev.
D17-0728-30	7/28/2017	D. HAGAN	A



PC031
J-SHAPED MIDLINE ARM

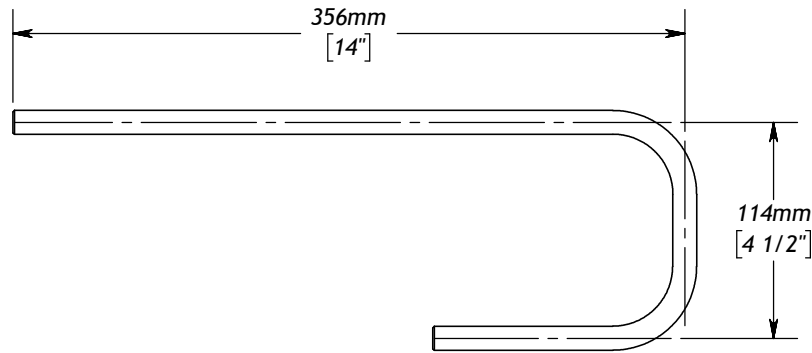

PC032
L-SHAPED MIDLINE ARM

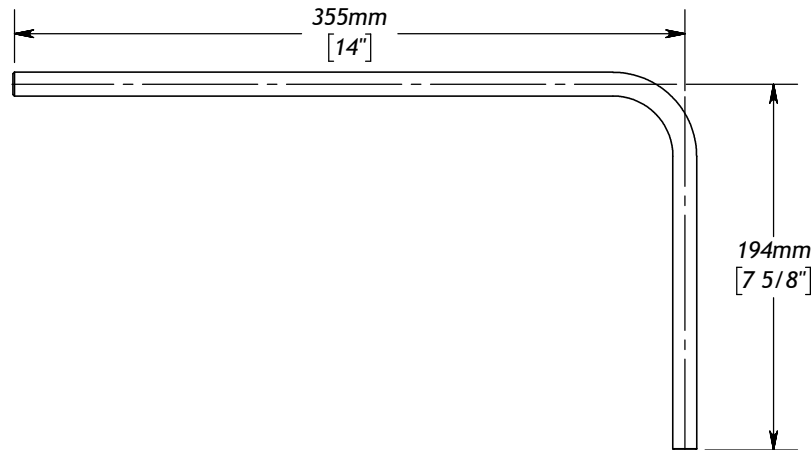

PC033
STRAIGHT MIDLINE ARM

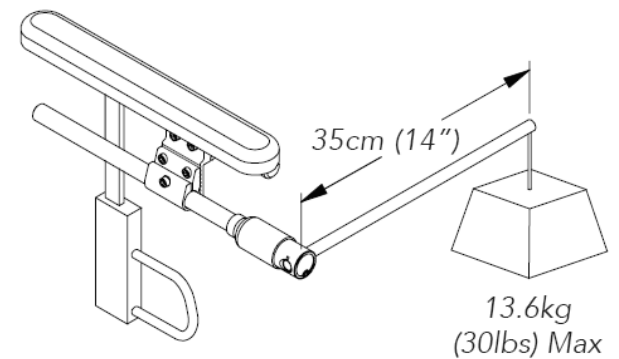
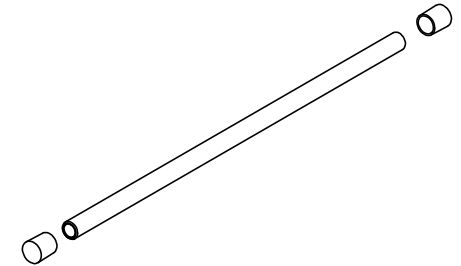
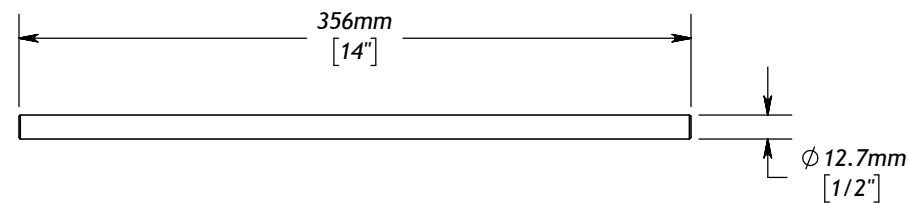

MIDLINE ARMS ARE MADE FROM HEAVY GAUGE STAINLESS STEEL TUBING, AND MAY BE SHORTENED USING A TUBING CUTTER OR HACKSAW. REPLACE PLASTIC END CAPS AFTER CUTTING.

description			
TRI-LOCK ROTATING SHAFT & MIDLINE ARM SPECS			
drawing no.	date originated	drawn by	rev.
D17-0728-30	7/28/2017	D. HAGAN	A