

Manual Hydraulic (Item: L350C) Mobile Patient Lift

User Manual



DEALERS: This manual **MUST** be given to the user of the patient lift.

USER: Before using this patient lift, read this manual and save for future reference.

Table of Contents

1.0	GENERAL INFORMATION.....	2
1.1	STANDARD SYMBOLS AND WARNING LABELS.....	2
1.2	INTENDED USE.....	2
1.3	SAFETY PRECAUTIONS.....	3
1.4	LIFE EXPECTANCY.....	6
2.0	TECHNICAL SPECIFICATION.....	7
2.1	PATIENT LIFT.....	7
3.0	EQUIPMENT ASSEMBLY.....	8
3.1	UNPACKING THE PATIENT LIFT.....	8
3.2	ASSEMBLING THE PATIENT LIFT.....	10
4.0	EQUIPMENT OPERATION.....	14
4.1	OPERATING THE PATIENT LIFT.....	14
5.0	LIFTING THE PATIENT.....	16
5.1	PREPARING THE LIFT FOR USE.....	16
5.2	LIFTING/MOVING THE PATIENT.....	17
5.3	TRANSFERRING THE PATIENT.....	18
6.0	MAINTENANCE & CLEANING.....	21
6.1	MAINTENANCE SCHEDULE.....	21
6.2	DETECTING WEAR AND DAMAGE.....	22
6.3	LUBRICATION.....	22
6.4	CHECKING AND TIGHTENING MAST PIVOT BOLT.....	23
6.5	REPLACING THE HYDRAULIC PUMP.....	24
6.6	REPLACING THE SWIVEL BAR.....	25
6.7	MAINTAINING THE BASE ADJUSTMENT.....	26
6.8	REPLACING THE CASTERS/FORKS.....	26
6.9	CLEANING.....	28
7.0	TROUBLESHOOTING GUIDE.....	29
8.0	LIMITED WARRANTY.....	30
	APPENDIX – SERVICE RECORD.....	31

1.0 GENERAL INFORMATION

1.1 Standard Symbols and Warning Labels

Warnings

Signal words with symbols are used in this manual to highlight hazards or unsafe practices which could result in personal injury or property damage. See the information below for definitions of the signal words and symbols.



DANGER

Danger indicates an imminently hazardous situation which, if not avoided, will result in death or serious injury.



WARNING

Warning indicates a potentially hazardous situation which, if not avoided, could result in death or serious injury.



CAUTION

Caution indicates a potentially hazardous situation which, if not avoided, may result in property damage or minor injury or both.



IMPORTANT

Indicates a hazardous situation that could result in damage to equipment or property if it is not avoided.



Gives useful tips, recommendations and information for ease of use.

1.2 Intended Use

The Manual Patient Lift is intended for use in within an institutional healthcare environment, i.e. hospitals, nursing homes, rehabilitation care, assisted living.

The patient lift is NOT a transport device. It is intended to transfer an individual from one resting surface to another (such as a bed to a wheelchair).

DO NOT attempt any transfer without approval of the patient's physician, nurse or medical assistant.

The lifts are intended for users who fully understood the content of this manual and is not intended for use by children.

1.3 Safety Precautions

1.3.1 Assembling the Lift



WARNING

DO NOT overtighten the mounting hardware as this will damage the mounting brackets.

1.3.2 Operating the Lift



WARNING

DO NOT exceed maximum weight limitation of the patient lift. The weight limitation for the lift is 450 lbs.

ALWAYS keep hands and fingers away from moving parts to avoid injury.

Although two assistants are recommended for all lifting preparation and transferring procedures, our equipment will permit proper operation by one assistant. The use of one assistant is based on the evaluation of the health care professional for each individual case.

1.3.3 Using the Slings



WARNING

Use a sling advised by the individual's doctor, nurse or medical assistant for the comfort and safety of the individual being lifted.

DO NOT insert any kind of plastic back incontinence pad or seating cushion between patient and sling material that may cause the patient to slide out of the sling during transfer.

After each wash (in accordance with instructions on the sling), inspect sling(s) for wear, tears, and loose stitching. Bleached, torn, cut, frayed, or broken slings are unsafe and could result in injury, and should be DISCARDED immediately.

DO NOT alter slings.

Be sure to check the sling attachments each time the sling is removed and replaced, to ensure that it is properly attached before the patient is removed from a stationary object (bed, chair or commode).

If the patient is in a wheelchair, secure the wheel locks in place to prevent chair movements that could lead to potential falls.

When connecting slings to the patient lift, make sure there is sufficient head support when lifting a patient.

1.3.4 Lifting the Patient



WARNING

When using the lift, the legs **MUST** be opened to the maximum position and locked before lifting the patient.

The rear casters of the patient lift **MUST** be kept unlocked when lifting an individual. Locking the casters during lifting procedures could cause the lift to tip and endanger the patient and assistants. The unlocked casters during lifting procedures will allow the patient lift to stabilize itself when the patient is initially lifted from a chair, bed or any stationary object.

Specific slings are made for the Manual Hydraulic Patient Lifts. For the safety of the patient, **DO NOT** intermix slings and patient lifts of different manufacturers. Warranty will be voided.

When the patient is elevated a few inches off a stationary surface and before moving the patient, check again to make sure that all hardware or straps are properly connected. If any attachment is **NOT** properly in place, lower the patient back onto the bed and rectify the issue.

Adjustments for safety and comfort should be made prior to moving the patient. Patient's arms should be kept inside of the straps.

During transfer, with patient suspended in a sling attached to the lift, **DO NOT** roll caster base over uneven surfaces that could cause the patient lift to tip over. Use steering handle on the mast at all times to maneuver the patient lift.

1.3.5 Transferring the Patient



WARNING

When the patient is elevated a few inches off a stationary surface and before moving the patient, check again to make sure that all hardware or straps are properly connected. If any attachment is NOT properly in place, lower the patient back onto the bed and rectify the issue.

Wheelchair wheels **MUST** be locked before lowering the patient into the wheelchair for transport.

Make sure the wheelchair weight capacity can withstand the patient's weight prior to loading the patient.

Be sure to check the sling attachments each time the sling is removed and replaced, to ensure that it is properly attached before the patient is removed from the bed or chair.

Mast pivot under the rubber boot must be tight to ensure safe use of the patient lift. Bolt must be checked at least every six months in conjunction with periodic maintenance.

1.3.6 Performing Maintenance



WARNING

ONLY qualified personnel should carry out the lift maintenance.

DO NOT attempt to open the pre-sealed hydraulic pump or obtain local service, for it will **VOID** the warranty and might result in damage. Consult your dealer or manufacturer for further information.

After the first year of operation, the hooks of the swivel bar and the mounting brackets of the boom should be inspected every three months to determine the extent of wear. If these parts become worn, replacement must be made.

After the first year of operation, inspect the swivel bar and the eye of the boom (to which it attaches) for wear. If the metal is worn, the parts **MUST** be replaced. Make this inspection every six months thereafter.

Inspect the casters and axle bolts every six months to check for tightness and wear.

Regular maintenance of patient lifts and accessories is necessary to ensure proper operation. DO NOT overtighten mounting hardware. This will damage mounting brackets.

1.3.7 Disposal



WARNING

This product has been supplied from an environmentally aware manufacturer.

This product may contain substances that could be harmful to the environment if disposed of in places (landfills) that are not appropriate according to legislation.

Please be environmentally responsible and recycle this product through your recycling facility at its end of life.

1.4 Life Expectancy

Lift - The lift expectancy of the lift is eight years, presuming that the product is used daily and in accordance with safety instructions and maintenance instructions stated in this manual.

2.0 TECHNICAL SPECIFICATION

2.1 Patient Lift

	L350C
Model Type	Hydraulic Manual Lift
Height at Sling Hook-up - MAX	67"
Height at Sling Hook-up - MIN	20.8"
Base Width OPEN	40"
BASE Width Closed	25"
Base Height (Clearance)	4.5"
Base Length	48"
Caster Size (Front/Rear)	3" / 5" (lockable)
Weight Capacity	450 lbs
Weight IN Carton	116 lbs
Weight OUT of Carton	93 lbs

3.0 EQUIPMENT ASSEMBLY

3.1 Unpacking the Patient Lift



WARNING

To avoid injury, DO NOT attempt to remove the lift from the carton without assistance.

- I. Unpack the components from the shipping carton.
- II. Upon unpacking your patient lift, the package should contain all of the following components.
- III. Examine exterior of the patient lift for nicks, dents, scratches or damages. Inspect all components.

Main component provided in the package:

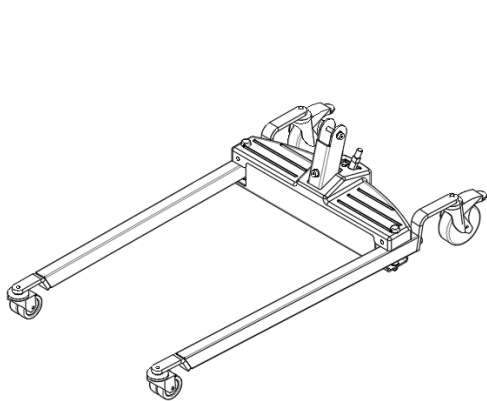

Lift Caster Base x 1

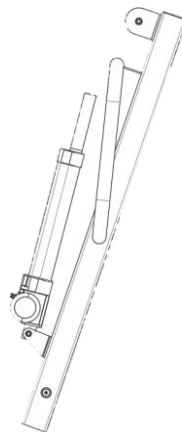

Mast assembly x 1

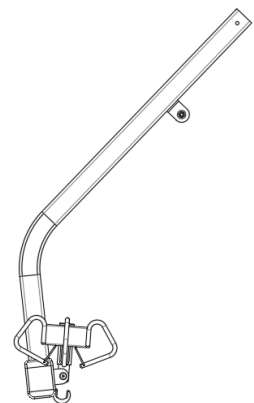

Boom assembly x 1

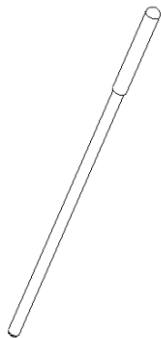

Shifter Handle x 1

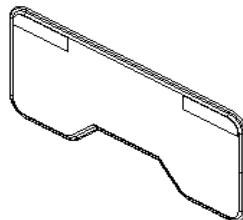

Swivel Bar Cover x 1
(Pre-wrapped on bar)

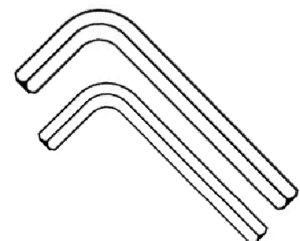

Allen Wrench x 2
(size M8 & M10)

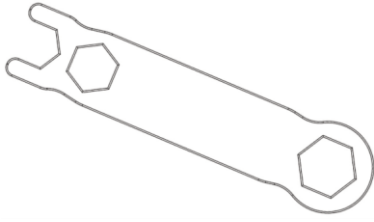

Shifter Handle x 1

YOU SHOULD PREPARE THE FOLLOWING TOOLS FOR THE LIFT ASSEMBLY:

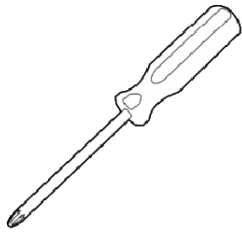

Crosshead Screwdriver x 1
(For Bariatric Lift Only)



Not all items provided in the carton are shown in the above. Pinch guards, bolts, washers and nuts are fastened to their intended locations and therefore omitted from the illustration.



IMPORTANT

Store the repackaged patent lift in a dry area. Do not place other objects on top of the repackaged patient lift.



Unless the lift is to be used immediately, retain boxes, containers, and packing materials for use in storing until use of patient lift is required.

3.2 Assembling the patient lift



WARNING

Use only parts supplied by the manufacturer for assembly. The base legs, the mast, boom, hydraulic pump assembly and the swivel bar are manufactured to specifications that assure correct alignment of all parts for safe operation.

3.2.1 Assembling the mast to the base

- I. Step on the locking levers to lock the two rear casters at the base.

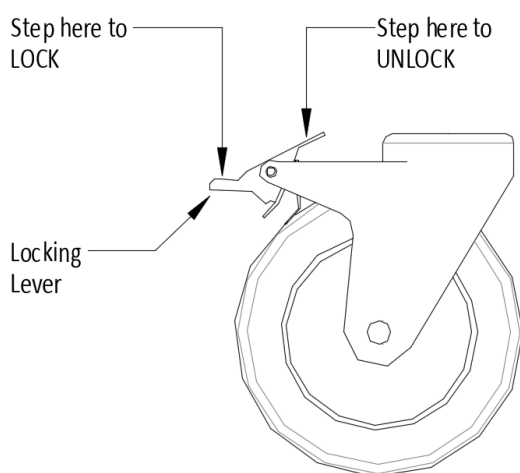

- II. Remove the shoulder bolt, washer and nut fastened to the base of the mast.
- III. Position the mast in an upright position and place the mast over the U-shape cut-out of the base.
- IV. Insert shoulder bolt with washers through the base and mast.
- V. Secure with nut.

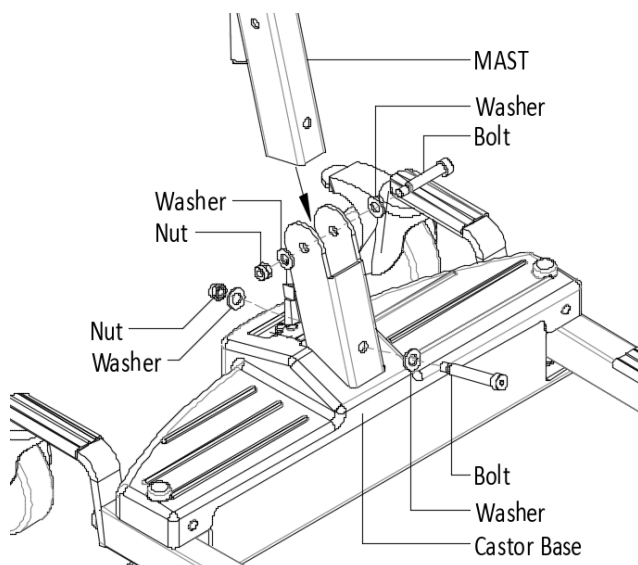



WARNING

For storage or transport, the mast may be disconnected from the base. Each time the mast is removed and returned to the base, the mast **MUST** be properly secured to the base assembly.

3.2.2 Assembling the boom to the mast

- I. Step on the locking levers to lock the two rear casters at the base.
- II. Align the mounting holes with the bracket on the mast.
- III. Secure the boom to the mast with a bolt, washer and nut.

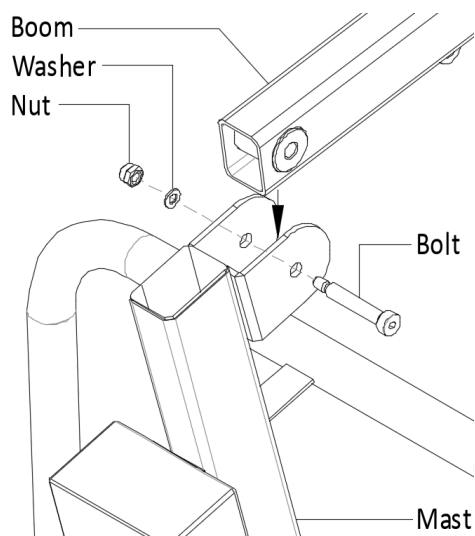

3.2.3 Assembling the hydraulic pump to the boom

i The bottom of the hydraulic pump assembly will be preassembled to the mast mounting bracket.

- I. Remove the shoulder bolt, washer and nut fastened to the boom mounting bracket.
- II. Lift-up on the boom and place it on your left shoulder.
- III. Align the holes of the boom assembly mounting bracket with those of the hydraulic pump and insert the bolt. Secure with nut.

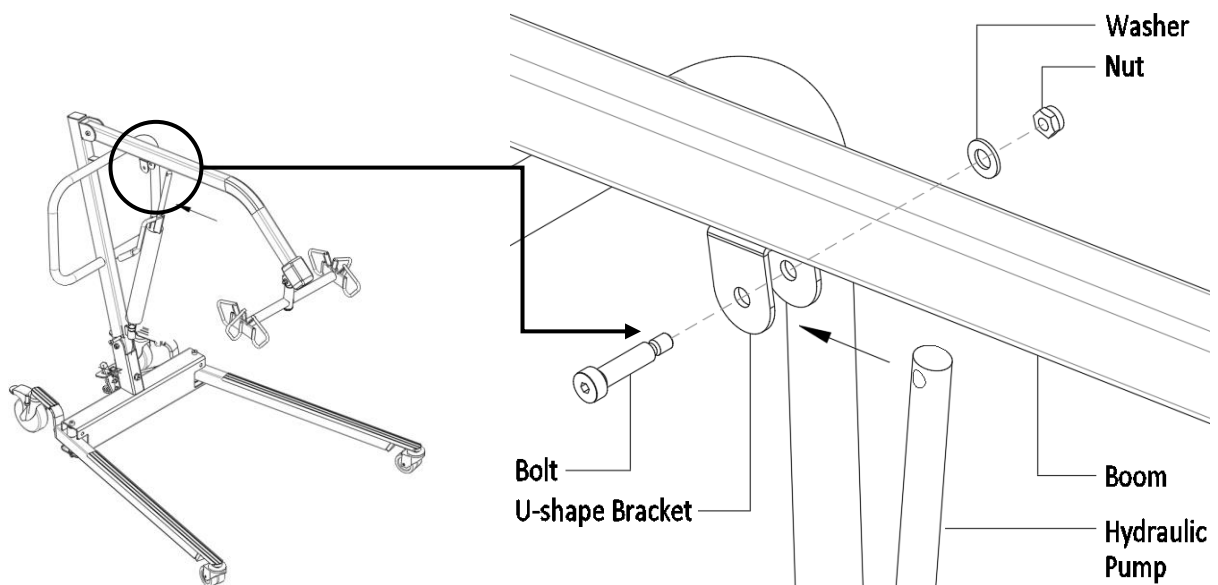

i Be sure that the bolt is completely through the holes of the boom assembly mounting bracket and the hydraulic pump assembly. The boom assembly will pivot easily if the mounting hardware is aligned properly when the boom assembly is secured.

3.2.4 Installing the shifter handle

- I. Line-up the shifter handle opening with the threaded connector at the base.
- II. Turn the shifter handle clockwise and securely tighten into the base.
- III. Secure the shifting handle in place with a cross head screw.

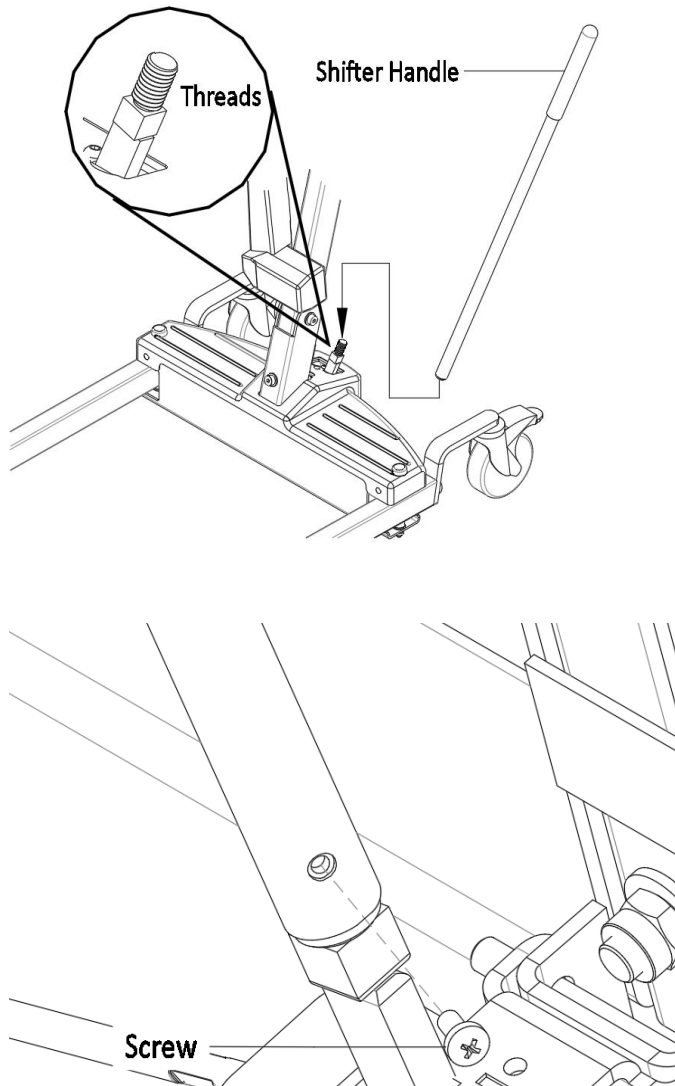

4.0 EQUIPMENT OPERATION

4.1 Operating the patient lift

4.1.1 Closing/Opening the Legs of the lift base

Stand at the rear of the lifter and grasp the shifter handle. Swivel the shifter handle to open and close the legs of the base.



The shifter handle **MUST** lock into its mounting slot to lock the legs in the full close/open position.



WARNING

The shifter handle **MUST** be positioned completely into its mounting slot. **DO NOT** use the patient lift until shifter handle is properly seated and the legs of the patient lift are locked in place. Otherwise, injury and/or damage may occur.

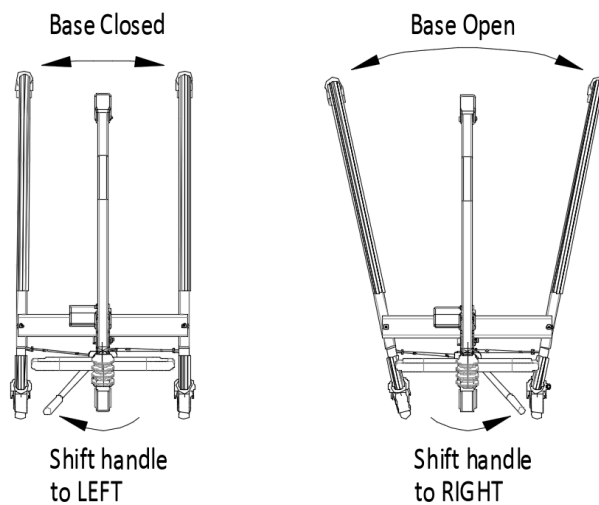

4.1.2 Raising/lowering the lift



WARNING

The rear casters of the patient lift should not be locked when lifting an individual. Locked casters could cause the lift to tip and endanger the patient and assistants. It is recommended that the rear casters be left unlocked during lifting procedures to allow the patient lift to stabilize itself when the patient is initially lifted from a chair, bed or any stationary object.

- I. To raise the patient, first make sure the control valve is at close position (Valve handle parallel to the pump handle).
- II. Maneuver the pump handle in an up and down motion to lift up the patient.
- III. To lower the patient, turn the control valve away from the pump handle in the open position. The weight of the patient will lower the lift. The degree of control valve opening will vary the speed of descent.



The safety mechanism built into the lift allows the patient to descend slowly even when the control valve is fully open.

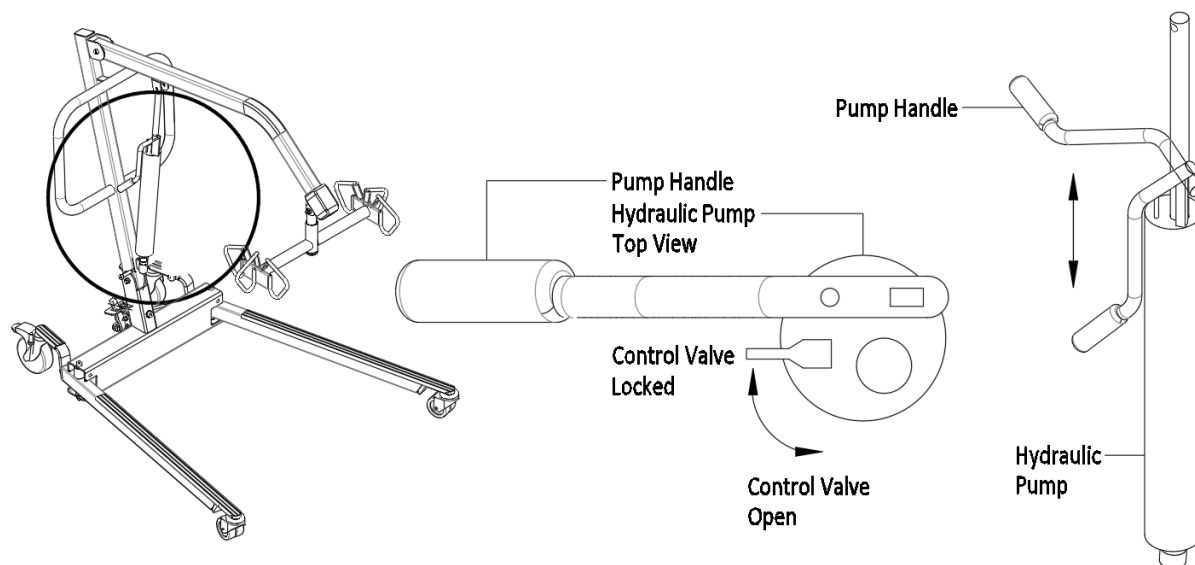

5.0 LIFTING THE PATIENT

5.1 Preparing the lift for use

5.1.1 Positioning the lift for use

- I. With the legs of the base open and locked, use the steering handle to push the patient lift into position.
- II. Lower the patient lift for easy attachment of the sling.



WARNING

The legs of the lift must be in the maximum open position and the shifter handle locked in place for optimum stability and safety. If it is necessary to close the legs of the lift to maneuver the lift under a bed, close the legs of the lift only as long as it takes to position the lift over the patient and lift the patient off the surface of the bed. When the legs of the lift are no longer under the bed, return the legs of the lift to the maximum open position and lock the shifter handle immediately.

5.1.2 Prepare the Sling at Lying Position

- I. Carefully and gently roll the patient on their side. The sling seat should be folded lengthwise and placed under the patient so that the lower edge of the seat is slightly below the back.
- II. Roll the patient back onto their other side and pull the sling seat so that it unfolds under the patient. Then pull the leg loops forward and under the patient's thighs. The loops should come through the patient's legs. Then cross the loops.
- III. With the boom of the lift lowered, place the straps of the sling over hooks of the swivel bar.



5.1.3 Prepare the Sling at Seated Position



WARNING

Where the patient is seated in a wheelchair, the wheels **MUST** be locked when putting on the sling.

- I. Lean patient forward and set the folded sling behind the patient's back. Set the sling as far down as possible until it touches the back of the seat.
- II. Open the sling, pull the bottom loop section of the sling under patient's thighs then cross the loops.
- III. With the lift in position and boom lowered, place the straps of the sling over hooks of the swivel bar.



5.2 Lifting/Moving the Patient



WARNING

Before lifting or transferring the patient, the base legs **MUST** be locked in the open position for optimum stability and safety. **DO NOT** engage the rear locking casters when patient is in the lift.

- I. Using the steering handle, push the patient lift underneath the bed.
- II. With the sling securely attached to the lift, press the UP (▲) button to raise the patient above the bed. The patient should be elevated high enough to clear the bed and their weight supported by the lift.



WARNING

When the patient is elevated a few inches off the surface of the bed and before moving the patient, check again to make sure that all hardware or straps are properly

connected. If any attachment is NOT properly in place, lower the patient back onto the bed and rectify the issue.

- III. When the patient is lifted from the bed (with the patient's head supported), he/she will be raised to a sitting position.
- IV. When the patient is clear of the bed surface, swing their feet off the bed.
- V. Using the steering handle, move the lift away from the bed.
- VI. When moving the patient lift away from the bed, turn the patient so that he/she faces assistant operating the patient lift.
- VII. Press the DOWN (▼) button lowering patient so that his feet rest on the base of the lift, straddling the mast.
- VIII. With both hands firmly on the steering handle, pull the patient lift away from the bed and then push it from behind.

5.3 Transferring the patient



WARNING

When the patient is elevated a few inches off a stationary surface and before moving the patient, check again to make sure that all hardware or straps are properly connected. If any attachment is NOT properly in place, lower the patient back onto the bed and rectify the issue.



WARNING

Before lifting or transferring the patient, the base legs MUST be locked in the open position for optimum stability and safety. DO NOT engage the rear locking casters when patient is in the lift.

5.3.1 Transferring the patient from and to a car



It is recommended that two assistants to help transferring a patient from a car to a wheelchair.

- I. To transfer a patient away from a car, with the first assistant supporting the patient, the second assistant lower the boom of the patient lift until the hooks of the swivel bar are even with the roof of the car.
- II. Attach the sling to the swivel bar.
- III. Lift the patient up off of seat until straps are taut.
- IV. Turn patient with sling until legs are outside of car.

- V. Lift up on legs with one hand and tilt the patient back with the other hand.
- VI. The second assistant should pull the patient lift away from the car until the patient is completely clear of the door frame.
- VII. Release the patient back to his/her normal sitting position in the sling.
- VIII. Place patient in wheelchair, refer to Transferring the patient to a wheelchair section of this manual.
- IX. To transfer a patient to the car, reverse the above steps.

5.3.2 Transferring the patient for using a commode chair or standard commode

The slings with commode openings are designed to be used with either a commode chair or standard commode.



It is recommended that the sling remain connected to the swivel bar during the patient's use of either the commode chair or standard commode.

- I. With the patient correctly positioned on the sling, attached the sling to the swivel bar.
- II. The patient should be elevated high enough to clear the commode chair/standard commode and their weight supported by the lift.
- III. With the help of both assistants, guide the patient onto the commode chair/standard commode.
- IV. Lower the patient onto the commode chair/standard commode leaving the sling attached to the swivel bar.
- V. When complete, recheck for correct attachment and then raise the patient off the commode chair.
- VI. When patient is clear of the commode surface (using the steering handles), move the lift away from the commode chair/standard commode.
- VII. To return patient to bed, reverse procedures concerning lifting the patient, operation and sling attachment.
- VIII. To return or place patient in a wheel chair, refer to Transferring the patient to a wheelchair section of this manual.



The lift is NOT a transport device. Where it is difficult to maneuver the lift towards the commode or the bathroom facility is too far from the bed, the patient MUST be transported to a wheel chair first.

5.3.3 Transferring the patient for using a bath

- I. Move the patient from the bed onto the wheelchair, refer to Transferring the patient to a wheelchair section of this manual.
- II. The patient should be elevated high enough to clear the wheelchair and their weight supported by the lift.
- III. Lower the patient into the portable bath tub.
- IV. Disconnect the chains/straps from sling and reattach to the portable bath tub.
- V. With the lift, raise the sides of the portable bath tub.
- VI. Bathe the patient.
- VII. To return to the bed, reverse procedures concerning lifting the patient, operation and sling attachments.

5.3.4 Transferring the patient to a wheel chair



WARNING

The wheelchair wheels **MUST** be locked before lowering the patient into the wheelchair for transport.

- I. The legs of the lift (with patient) shall be in open position.
- II. Move the wheelchair into position.
- III. Ensure the rear wheels of the wheelchair are locked to prevent further movement of the chair.
- IV. Position the patient over the seat with their face away from seat and their back against the back of the chair.



Use the straps or handles on the side and the back of the sling to guide the patient's hips as far back as possible into the seat for proper positioning.

- V. Lower the patient by pressing the DOWN (▼) button on the lift controller.
- VI. With one assistant behind the chair and the other operating the patient lift, the assistant behind the chair will pull back on the grab handle (on select models) or sides of the sling to seat the patient well into the back of the chair. This will maintain a good center of balance and prevent the chair from tipping forward.
- VII. Disconnect the sling from the patient lift.
- VIII. To return to the bed, reverse procedures concerning lifting the patient, operation and sling attachments.

6.0 MAINTENANCE & CLEANING

6.1 Maintenance Schedule

ITEM	INITIALLY	INSTITUTIONAL INSPECT & ADJUST (MONTHLY)	IN-HOME INSPECT & ADJUST (6 MONTHS)
THE CASTER BASE - Base opens/closes with ease - Inspect for missing hardware - Inspect casters and axle bolts for tightness - Inspect casters for smooth swivel and roll - Inspect and clear debris on casters	<input type="radio"/> <input type="radio"/> <input type="radio"/> <input type="radio"/> <input type="radio"/>	<input type="radio"/> <input type="radio"/> <input type="radio"/> <input type="radio"/> <input type="radio"/>	<input type="radio"/> <input type="radio"/> <input type="radio"/> <input type="radio"/> <input type="radio"/>
SHIFTER HANDLE - Smooth operation - Locks adjustable base when slotted into mounting holes	<input type="radio"/> <input type="radio"/>	<input type="radio"/> <input type="radio"/>	<input type="radio"/> <input type="radio"/>
THE MAST - Securely attached to the boom - Inspect for deformation	<input type="radio"/> <input type="radio"/>	<input type="radio"/> <input type="radio"/>	<input type="radio"/> <input type="radio"/>
THE BOOM - Inspect all hardware and swivel bar supports - Inspected joints for wear - Inspect for deformation - Inspect the mast pivot joint. Ensure the bolt is properly secured.	<input type="radio"/> <input type="radio"/> <input type="radio"/> <input type="radio"/>	<input type="radio"/> <input type="radio"/> <input type="radio"/> <input type="radio"/>	<input type="radio"/> <input type="radio"/> <input type="radio"/> <input type="radio"/>
THE SWIVEL BAR - Inspect the bolt/hooks for wear and tear - Inspect the sling hooks for wear or deformation	<input type="radio"/> <input type="radio"/>	<input type="radio"/> <input type="radio"/>	<input type="radio"/> <input type="radio"/>

ITEM	INITIALLY	INSTITUTIONAL INSPECT & ADJUST (MONTHLY)	IN-HOME INSPECT & ADJUST (6 MONTHS)
THE HYDRAULIC PUMP ASSEMBLY - Inspect hardware on mast and boom - Inspect joints with mast and boom - Inspect for wear and deformation - Check for leakage	O O O O	O O O O	O O O O
SLING AND HARDWARE - Check all sling attachments EACH TIME IT IS USED* to ensure proper connection and patient safety - Inspect sling fabric for wear - Inspect strap for wear	O* O O	O* O O	O* O O
CLEANING - Whenever necessary	O	O	O



For individual home use, a full inspection is required prior to each new user.

Regular cleaning will reveal loose or worn parts, enhanced smooth operation and extend the life expectancy of the lift. Following the maintenance procedures detailed in the manual to keep your patent lift in continuous service.

6.2 Detecting Wear and Damage

When examining the equipment, attention should be paid to all stressed parts, such as slings, swivel bar and any pivot for slings for signs of cracking, fraying, deformation or deterioration. Replace any defective parts immediately and ensure that the lift is not used until repairs are made.

6.3 Lubrication

Minimum maintenance is required for the lifts. A check and lubrication every six month should ensure continued safety and reliability.

The lift and slings should be kept clean and in good working order. Any defect should be noted and reported to your dealer as soon as possible.

The casters MUST swivel and roll smoothly. A light grease (waterproof auto lubricant) may be applied to the ball bearing swivel of the casters once a year. Apply more frequently if the casters are exposed to extreme moist conditions.

Refer to the below figure for lubrication points. Lubricate all pivot points. Wipe all excess lubricant from lift surface.

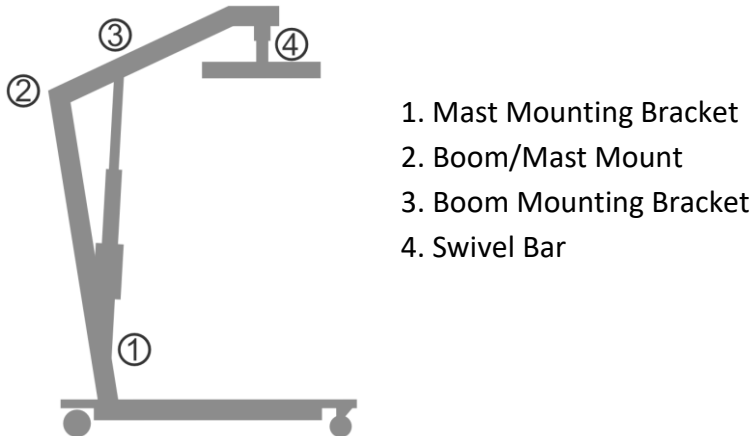

6.4 Checking and Tightening Mast Pivot Bolt

- I. Inspect the pivot point, check that the bolt is through the bracket and the locknut is tight and secure.
- II. If needed, do one or more of the following:
 - Tighten locknut and back-off the locknut 1/8 of a turn.
 - Replace the locknut.

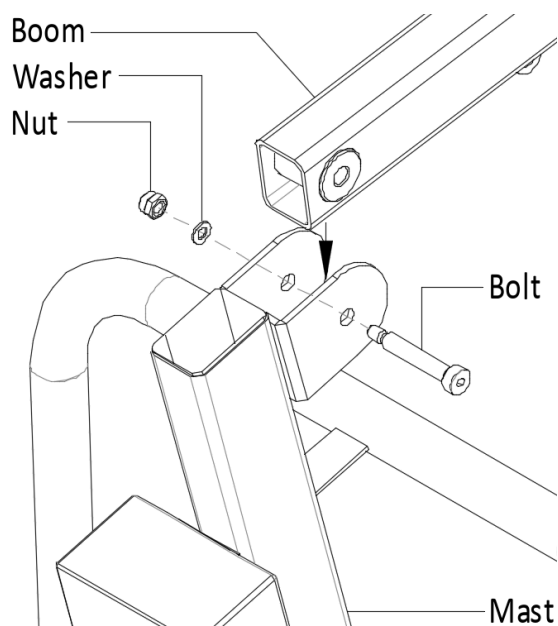

6.5 Replacing the Hydraulic Pump

- I. Remove the shoulder bolt, nut, and washer that secure the hydraulic pump to the mast mounting bracket.
- II. Rest the boom on your shoulder, rotate lock nut at the bottom of the hydraulic pump anti-clockwise to loosen the hydraulic pump from the mast mounting bracket.
- III. Remove the hydraulic pump.
- IV. Reverse the procedure for new pump installation.

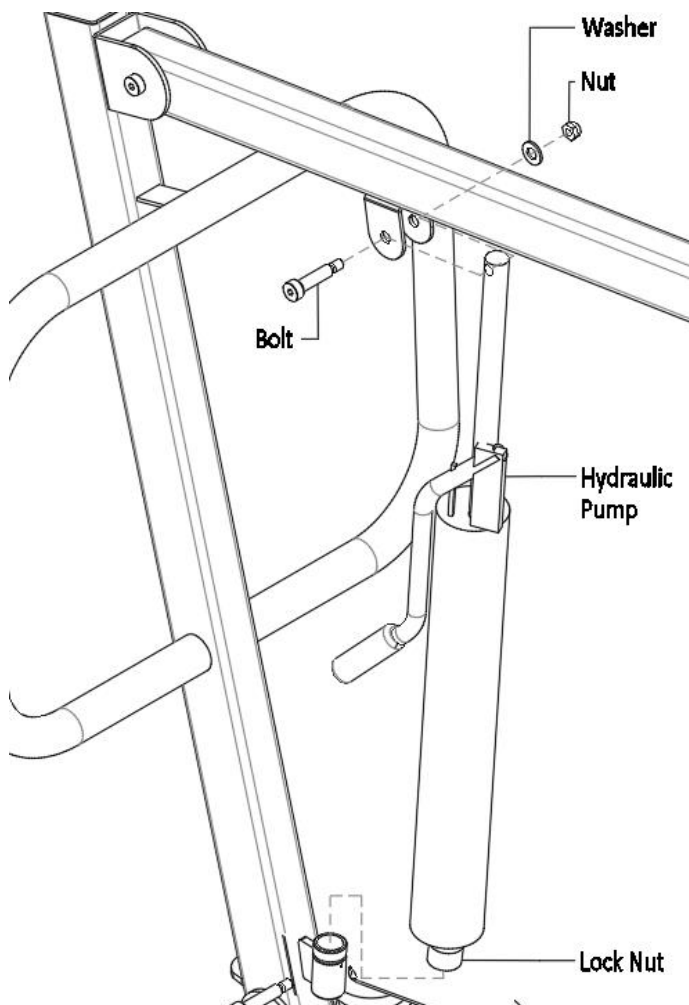

6.6 Replacing the Swivel Bar

- I. The hanger bar comes attached to the boom with bolt, nut, washers, and pinch guard.
- II. Remove existing hardware and replace the hanger bar.

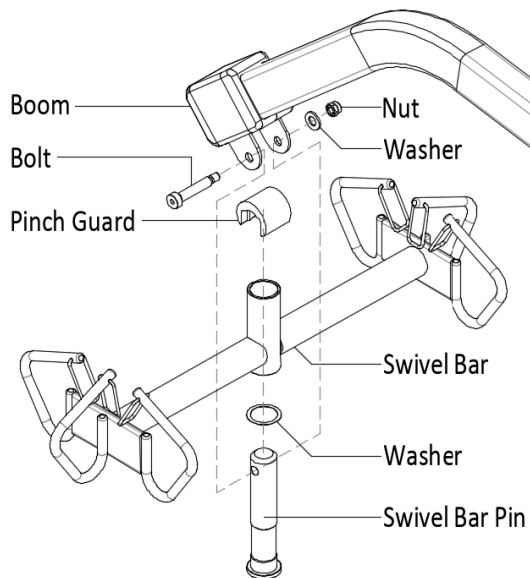

WARNING

After the first year of use, the hooks of the swivel bar and mounting brackets of the boom should be inspected every six months to determine the extent of wear. If these parts become worn, replacement must be made.

6.7 Maintaining the Base Adjustment

The base adjustment should not require any attention other than:

- I. Check the squareness of the legs when in the closed position.
- II. Place a square on the inside of the legs and base to determine the 90° alignment.
- III. Loosen the nut on the linkage rod, rotate the linkage rods until 90° alignment is achieved. Tighten the nut.

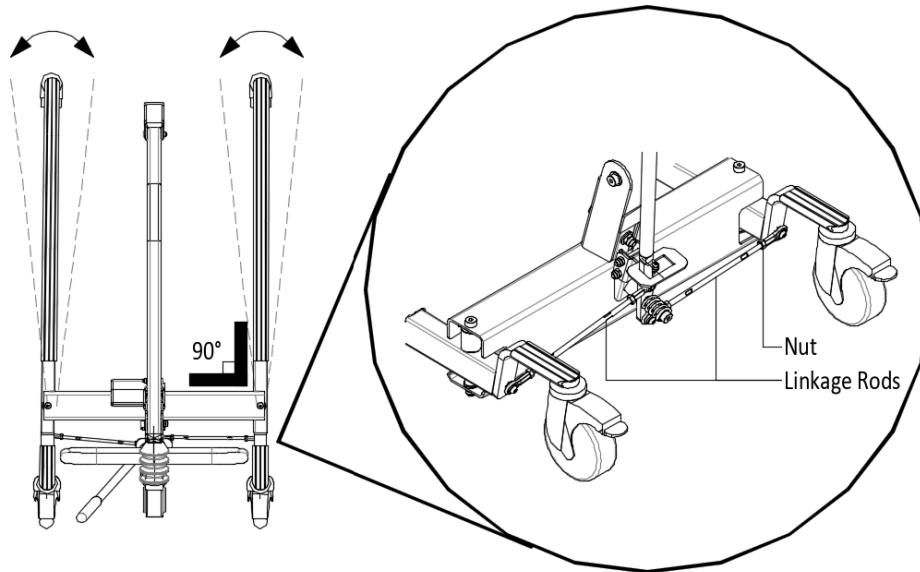

6.8 Replacing the Casters/Forks

6.8.1 Replacing rear casters

- I. Turn and place the lift on its side.
- II. Remove the bolt and nut securing the existing rear caster to the fork.
- III. Install the new/existing bearing into the new rear caster.
- IV. Align the mounting holes in the new rear caster and the fork.
- V. Insert the bolt through the fork and new rear caster and tighten with the nut.



When disassembling the rear casters, the bearing will become loose and may fall out of the caster, it can be reused if not worn.

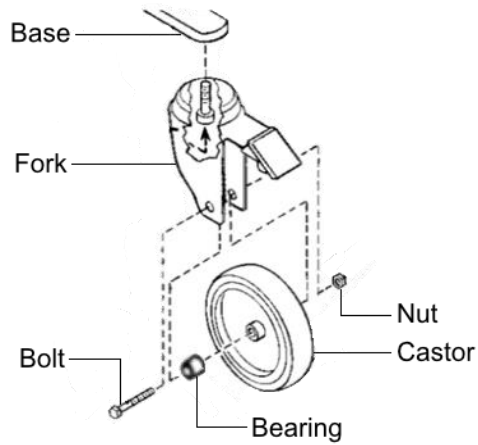

6.8.2 Replacing front casters

- I. Turn and place the lift on its side.
- II. Remove the bolt and nut securing the existing front castor assembly to the fork.
- III. Position the new/existing washer between the two new casters.
- IV. Align the mounting holes in the new front castor assembly and the fork.
- V. Insert the bolt through the fork and the new front castor assembly and tighten with the nut.



When disassembling the front casters, the washers between two wheels will fall out and can be reused, replace if worn.

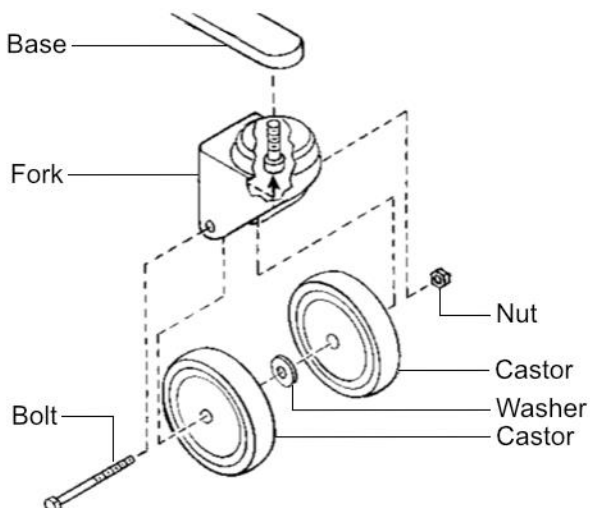

6.8.3 Replacing caster forks

- I. Turn and place the lift on its side.
- II. Remove the front or rear caster from the lift. Refer to Section 6.8.1 and 6.8.2.
- III. Unscrew the existing fork from the base.
- IV. Install the new fork onto the base.
- V. Install the front or rear caster onto the lift. Refer to Section 6.8.1 and 6.8.2.

6.9 Cleaning

A soft cloth, dampened with water and a small amount of mild detergent, is all that is needed to clean the patient lift. The lift can be cleaned with non-abrasive cleaners. Auto wax or furniture polish will help maintain the sparking finish over a long period of time.

Ensure casters are free of debris.

7.0 TROUBLESHOOTING GUIDE

SYMPTOMS	FAULTS	SOLUTIONS
Pump assembly idle when pump handle is engaged.	Hydraulic pump in need of service or load is too high.	Reduce load. Replace if worn.
Patient lift feels loose.	Mast/Base joint loose.	Refer to Section 3.2 & 6.4.
Casters/Brakes noisy or stiff.	Debris or fluff in bearings	Replace casters.
Noisy or dry sound from pivots.	Needs lubrication.	Lubricate your lift.
Unusual noise from pump.	Pump is worn or damaged or spindle is bent.	Replace the pump. Contact your supplier.
Lift arms will not lower when pump control valve is opened.	Lift arms require a minimum weight load to lower when control valve is opened.	Pull down slightly on the lift arms.



If problems persist following the above remedial procedures, please contact your dealer or the manufacturer.

8.0 LIMITED WARRANTY

This Costcare product is warranted to be free of defects in material and workmanship for one year of the original purchaser.

This device was built to exact standards and carefully inspected prior to shipment. This Limited One Year Warranty from the date of original purchase is an expression of our confidence in the material and workmanship of our products and our assurance to our customers for years of dependable services.

In the event of a defect covered by this warranty, Costcare will, at Costcare's option, repair or replace the device. The warranty provides only for replacement of defective parts and does not cover shipping and labor charges. Costcare's sole obligation and your exclusive remedy under this warranty are limited to such repair and/or replacement.

This warranty does not cover device failure due to the user misuse, abuse, negligence, or normal wear and tear. This warranty does not extend to non-durable components, such as rubber accessories, casters and grips, which are subject to normal wear and require periodic replacement.

This warranty shall not apply to serial numbered devices if the serial number has been removed, or altered, or defaced, or to defect or damages caused by unauthorized parts, attachments or repairs, negligence, operated by incorrect voltages, accident and circumstance beyond Costcare's control, or improper operation, maintenance or storage.

If you have a question regarding your Costcare device or this warranty, please contact an authorized Costcare Dealer.

The logo for Costcare, featuring the word "COSTCARE" in a bold, blue, sans-serif font, with a trademark symbol (TM) to the upper right of the "E".

