

CE800ENT Elliptical

OWNER'S MANUAL

CE800ENT_800052_20240118

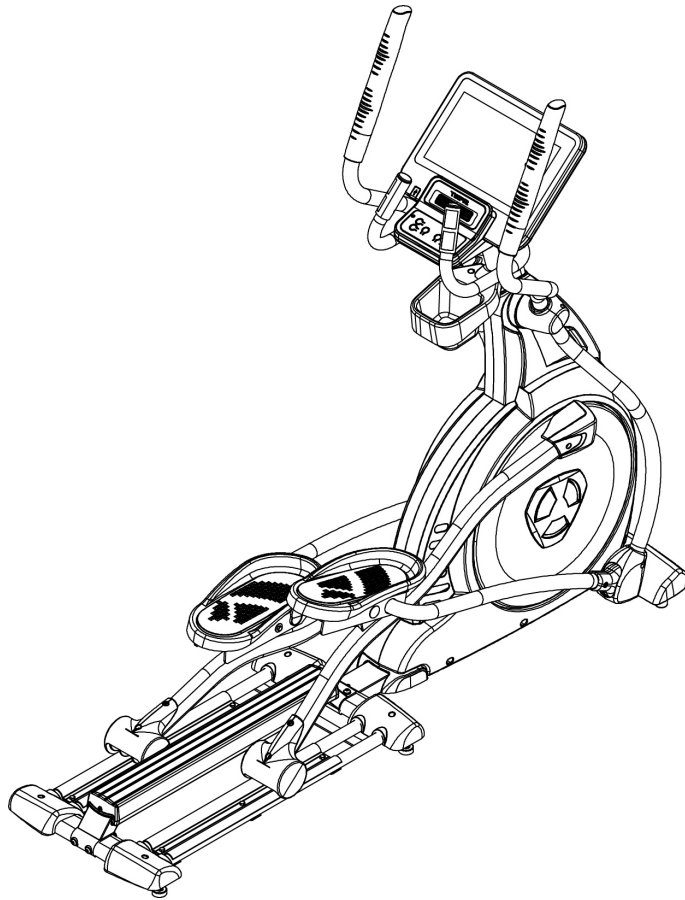

TABLE OF CONTENTS

3	PRODUCT REGISTRATION
4	IMPORTANT SAFETY INSTRUCTIONS
5	IMPORTANT ELECTRICAL INSTRUCTIONS
6	IMPORTANT OPERATION INSTRUCTIONS
7	CE800ENT ASSEMBLY INSTRUCTIONS
14	CONSOLE OPERATION
18	TOUCH SCREEN OPERATION
22	ENTERING PROGRAMS
24	PROGRAM DISPLAY
41	GENERAL MAINTENANCE
42	MANUFACTURER'S LIMITED WARRANTY
47	EXPLODED VIEW
48	PARTS LIST

Thank you for purchasing our product, please save these instructions. Please do not perform or attempt any customizing, adjustments, repair or maintenance that is not described in this manual.



Congratulations on your new Elliptical and welcome to the Spirit Fitness family!

Thank you for your purchase of this quality Elliptical from Spirit Fitness. Your new Elliptical was manufactured by one of the leading fitness manufacturers in the world and is backed by one of the most comprehensive warranties available. Through your dealer, Spirit Fitness will do all we can to make your ownership experience as pleasant as possible for many years to come. If not purchased direct from Spirit Fitness, the local dealership where you purchased this Elliptical is your administrator for all Spirit Fitness warranty and service needs. Their responsibility is to provide you with the technical knowledge and service personnel to make your experience more informed and any difficulties easier to remedy.

Please take a moment at this time to record the name of the dealer, their telephone number, and the date of purchase below to make any future, needed contact easy. We appreciate your support and we will always remember that you are the reason that we are in business.

Yours in Health,
Spirit Fitness

NAME OF DEALER _____

DEALER PHONE # _____

PURCHASE DATE _____

Serial Number:

REGISTER YOUR PURCHASE

The self-addressed product registration card must be completed in full and returned to Spirit Fitness.

IMPORTANT SAFETY INSTRUCTIONS

WARNING

When using an electrical appliance, basic precautions should always be followed, including the following:

Read all instructions before using this appliance.
DANGER – To reduce the risk of electric shock: Always unplug this appliance from the electrical outlet immediately after using and before cleaning.

WARNING – To reduce the risk of burns, fire, electric shock, or injury to persons, install the elliptical on a flat level surface with access to a 110-volt, 5-amp grounded outlet with only the elliptical plugged into the circuit.

DO NOT USE AN EXTENSION CORD UNLESS IT IS A 14AWG OR BETTER, WITH ONLY ONE OUTLET ON THE END:

- Do not operate elliptical on deeply padded, plush or shag carpet. Damage to both carpet and elliptical may result.

- Keep children away from the elliptical. There are obvious pinch points and other caution areas that can cause harm.
- Keep hands away from all moving parts.
- Never operate the elliptical if it has a damaged cord or plug. If the elliptical is not working properly, call your dealer.
- Keep the cord away from heated surfaces.
- Do not operate where aerosol spray products are being used or where oxygen is being administered. Sparks from the motor may ignite a highly gaseous environment.
- Never drop or insert any object into any openings.
- Do not use outdoors.
- To disconnect, turn all controls to the off position, then remove the plug from the outlet.
- Do not attempt to use your elliptical for any purpose other than for the purpose it is intended.
- The hand pulse sensors are not medical devices. Their purpose is to provide you with an approximate measurement in relation to your target heart rate. Use of a chest transmitter strap (sold separately) is a much more accurate method of heart rate analysis. Various factors, including the user's movement, may affect the

accuracy of heart rate readings. The pulse sensors are intended only as exercise aids in determining heart rate trends in general.

- Wear proper shoes. High heels, dress shoes, sandals or bare feet are not suitable for use on your elliptical. Quality athletic shoes are recommended to avoid leg fatigue.
- This appliance is not intended for use by persons with reduced physical, sensory or mental capabilities, or lack of experience and knowledge, unless they have been given supervision or instruction concerning use of the appliance by a person responsible for their safety.
- Keep children under the age of 13 away from this machine.
- Weight Limit: 450 lb

SAVE THESE INSTRUCTIONS - THINK SAFETY!

IMPORTANT ELECTRICAL INSTRUCTIONS

WARNING

NEVER remove any cover without first disconnecting AC power. If voltage varies by ten percent (10%)

or more, the performance of your Elliptical may be affected. Such conditions are not covered under your warranty. If you suspect the voltage is low, contact your local power company or a licensed electrician for proper testing. NEVER expose this elliptical to rain or moisture. This product is NOT designed for use outdoors, near a pool or spa, or in any other high humidity environment. The operating temperature specification is 40 to 120 degrees Fahrenheit, and humidity is 95% non-condensing (no water drops forming on surfaces).

- Circuit Breakers: Some circuit breakers used in homes are not rated for high inrush currents that can occur when a elliptical is first turned on or even during use. If your elliptical is tripping the house circuit breaker (even though it is the proper current rating) but the circuit breaker on the elliptical itself does not trip, you will need to replace the home breaker with a high inrush type. This is not a warranty defect. This is a condition we as a manufacture have no ability to control. This part is available through most electrical supply stores. *Examples: Grainger part # 1D237, or available online at www.squared.com part #QO120HM. The electrical outlet used should have a dedicated 5 amp circuit breaker.*

IMPORTANT OPERATION INSTRUCTIONS

- NEVER operate this elliptical trainer without reading and completely understanding the results of any operational change you request from the computer.
- Understand that changes in resistance do not occur immediately. Set your desired resistance level on the computer console and release the adjustment key. The computer will obey the command gradually.
- Use caution while participating in other activities while pedaling on your elliptical trainer; such as watching television, reading, etc. These distractions may cause you to lose balance which may result in serious injury.
- Do not use excessive pressure on console control keys. They are precision set to function properly with little finger pressure.

WARNING

This product can expose you to chemicals including Toluene and Acrylamide which are known to the State of California to cause Cancer and birth defects or other reproductive harm.

RECORD YOUR SERIAL NUMBER

Please record the serial number of this fitness product in the space provided below.

CE800ENT PRE-ASSEMBLY

UNPACKING

1. Cut the straps, then along the dotted line on the bottom of the box; lift the box over the unit and unpack.
2. Locate the hardware package. The hardware is separated into four steps. Remove the tools first. Remove the hardware for each step as needed to avoid confusion. The numbers in the instructions that are in parenthesis (#) are the item number from the assembly drawing for reference.

TOOLS INCLUDED:

- 13/14mm Wrench
- 14/17mm Wrench
- Phillips Screwdriver
- L Allen Wrench
- M12 Allen Wrench

PARTS INCLUDED:

- 1 Main Frame
- 1 Rail Assembly
- 1 Center Aluminum Rail
- 1 Console Mast
- 1 Console Mast Cover
- 1 Front Stabilizer Cover
- 2 Swing arms
- 2 Connecting Arms
- 1 Console
- 1 Water Bottle Holder
- 2 Foot Pedals
- 1 Hardware Kit

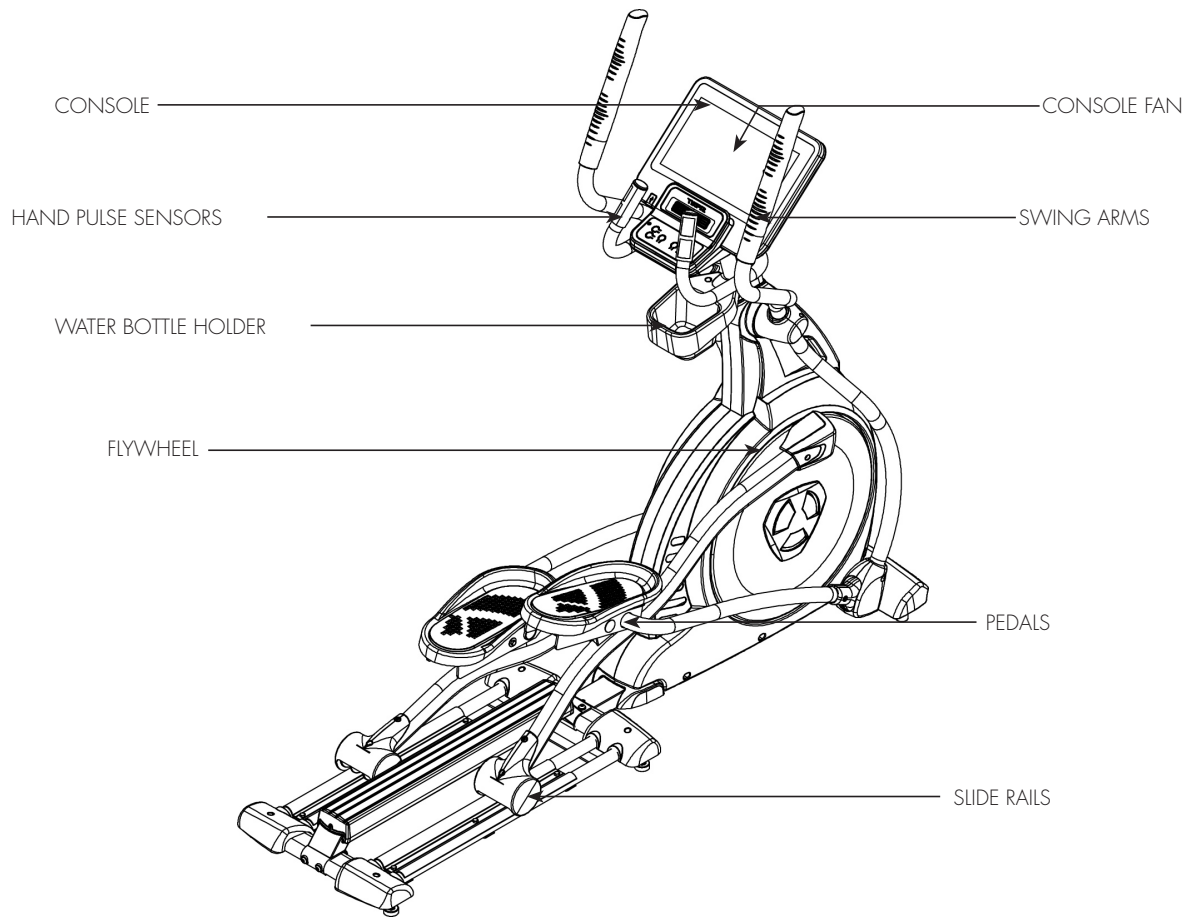

CE800ENT STEP ONE

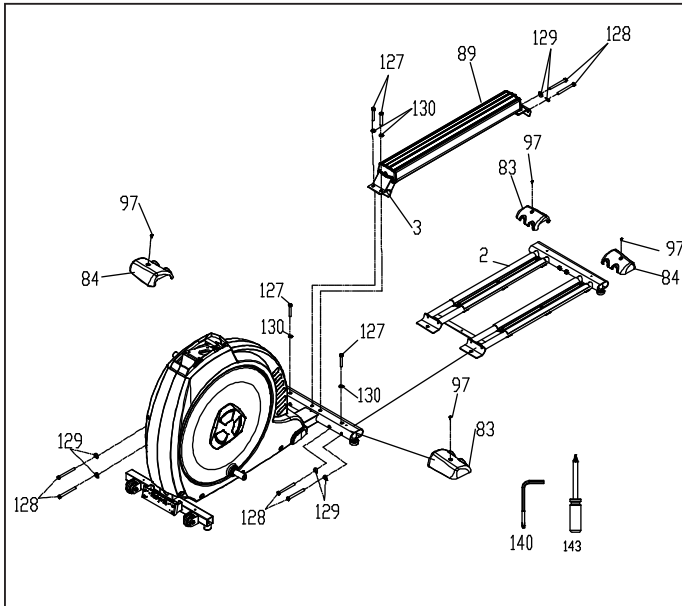

HARDWARE FOR STEP 1

PART	TYPE	DESCRIPTION	QTY
97	Philips Head Screw	M5 x 12mm	4
127	Button Head Socket Bolt	3/8" x 2-1/4"	4
128	Button Head Bolt	3/8" x UNC16 x 3-3/4"	6
129	Curved Washer	Ø3/8" x 23 x 2.0T	6
130	Flat Washer	Ø3/8" x Ø19 x 1.5T	4

1. Slide the **Rear Rail Assembly (No.2)** under the rear oval-shaped stabilizer tube on the **Main Frame (No.1)**. From the top of the stabilizer secure using 2 **Button Head Socket Bolts (No. 127)** and 2 **Flat Washers (No. 130)**. From the side secure with 4 **Button Head Bolts (No.128)** and 4 **Curved Washers (No.129)**.
2. Install the **Rail Support Assembly (No.3)** onto the **Main Frame (No.1)** and **Rear Rail Assembly (No.2)** using 2 **Button Head Socket Bolts (No. 127)** and 2 **Flat Washers (No.130)** on top. Use 2 **Button Head Bolts (No.128)** and 2 **Curved Washers (No.129)** at the rear.
3. Install the 4 **Tube Stabilizer Covers (No. 2 83/84)** using 4 **Screws (No. 97)**.

CE800ENT STEP TWO

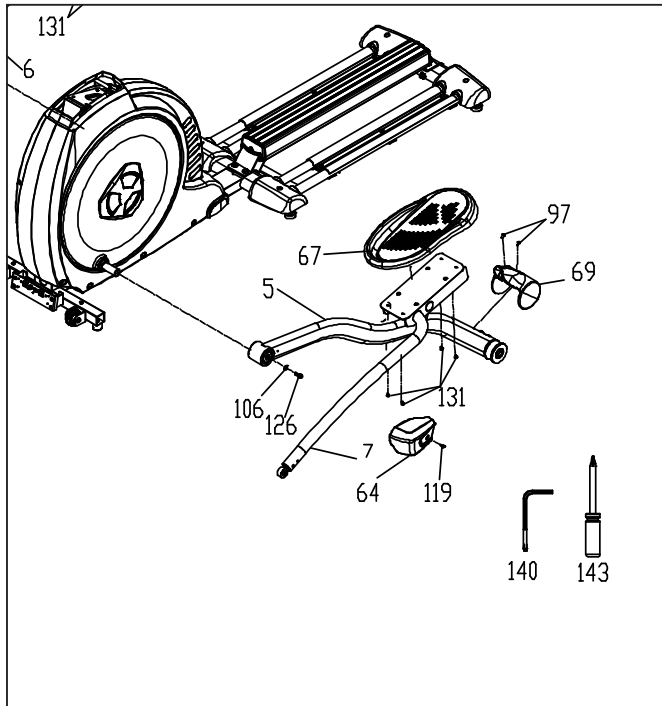

HARDWARE FOR STEP 2			
PART	TYPE	DESCRIPTION	QTY
97	Philips Head Screw	M5 x 12mm	4
106	Flat Washer	5/16"	2
119	Philips Head Screw	M6 x 15mm	2
126	Socket Head Cap Bolt	5/16" x 15mm	2
131	Philips Head Screw	M5 x 10mm	8

1. Attach the **Footplates (No. L 67)** to the pedal mounting plate with 4 **Screws (No.131)**.
2. Slide the **Pedal Arm Assembly (No.5)** onto the crank axle of the main frame. Be careful not to force it because damage to the bearings can occur. Secure with a **Bolt (126)** and a **Flat Washer (No.106)**.
3. Install the **Cover (No.64)** over the pedal arm connection at the rotation axle with a **Screw (No.119)**.
4. Install the **Roller Wheel Cover (No.69)** with 2 **Screws (No.97)**.
5. Repeat all steps with the opposite **Pedal Arm Assembly (No.6)**.

CE800ENT STEP THREE

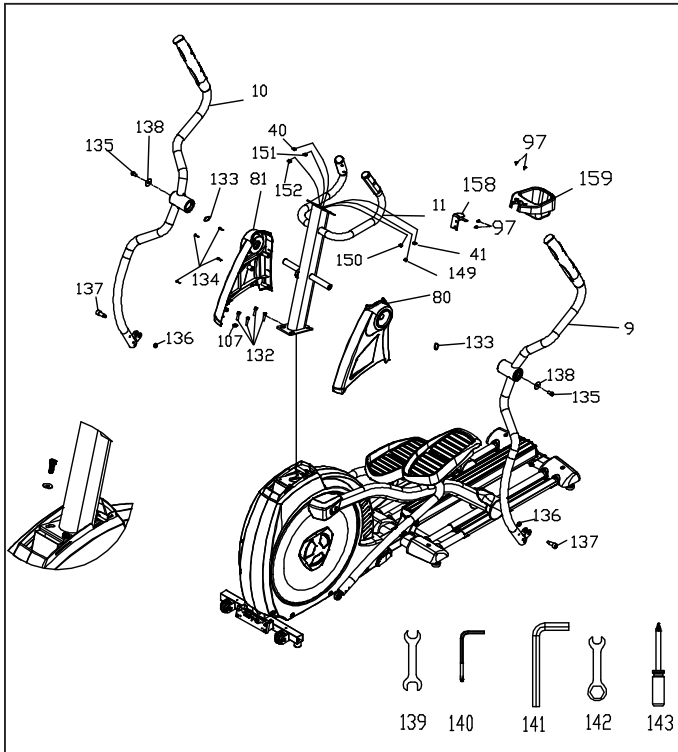

HARDWARE FOR STEP 3

PART	TYPE	DESCRIPTION	QTY
107	Flat Washer	5/16" x 23 x 1.5T	1
132	Socket Head Cap Bolts	M8 x 25mm	4
133	Wave Washer	25mm	2
134	Sheet Metal Screw	3.5 x 12mm	4
135	Hex Head Bolt	3/8" x 3/4"	2
136	Nylon Nut	M10 x 8T	2
137	Bolt	M10 x 1.5(14mm)	2
138	Flat Washer	3/8" x 30 x 2.0T	2
97	Screw	M5 x 12mm	4

1. Unravel the **Computer Cable (No.152)**, **CSAFE Connecting Wire (No.150)**, **Communication Cable (No.149)**, **HDMI Connecting Wire (No.151)** and snake it through the bottom of the **Console Mast (No.11)** and out the top. To install the **Mast Tube (No.11)**, first insert 3 **Socket Head Cap Bolts (No.132)** onto the mainframe then locate the **Mast Tube (No.11)** on its position and tighten three screws. Now the last **Bolt (No.132)** must be with **Flat Washer (No.107)** to tighten to the screw hole.
2. Mount the **Console Mast Covers (No. L80/R81)** with 4 **Screws (No.134)**.
3. Install 2 **Wave Washers (No.133)** onto the console mast axle then install the **Swing Arms (L9)(R10)** onto the axles. Do not force them or use a hammer as damage to the bearings can occur. Secure with a **Bolt (No.135)** and **Washer (No.138)** on each arm.

CE800ENT STEP THREE

4. Attach the bottom of the swing arms to the rod ends of the pedal arms using 2 **Shoulder Bolts (No.137)** and 2 **Nylon Nuts (No.136)**.
5. Attach the **Water Bottle Holder Clamp (158)** to console mast (11) with 2 **M5x12mm Philips Head Screw (97)**, then mount the **Water Bottle Holder (159)** to the **Water Bottle Holder Clamp (158)** using the 2 **M5x12mm Philips Head Screw (97)**.

CE800ENT STEP FOUR

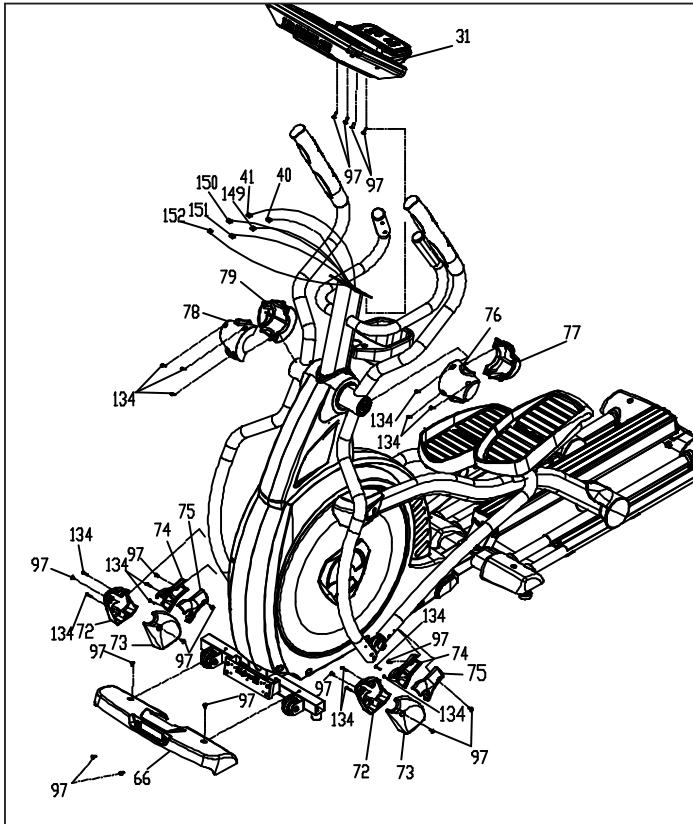

HARDWARE FOR STEP 4

PART	TYPE	DESCRIPTION	QTY
97	Philips Head Screw	M5 x 12mm	16
134	Sheet Metal Screw	3.5 x 12mm	14

1. Plug the **Computer Cable (No.152)**, **CSAFE Connecting Wire (No.150)**, **Communication Cable (No.149)**, **HDMI Connecting Wire (No.151)**, and **Handpulse w/Cable Assembly (No.40/41)** into the corresponding connectors on the back of the **Console (No.31)**. Mount the **Console (No. 30)** to the **Mast** with 4 **Screws (No.97)**.
2. Install 4 **Swing Arm Covers (No. 77/76 left & 78/79 right)** with 6 **Screws (No.134)**.
3. Install 4 **Covers (No. 74x2 & 75x2)** to the ends of the **Pedal Arms** with 4 **Screws (No.97)** and 4 **Screws (No.134)**. Be careful not to install these covers upside down! There is an arrow on the inside of each cover to indicate the correct installation direction.
4. Install the 4 **Covers (No.72 x 2 & 73 x 2)** to the connection point at the bottom of the swing arms using 4 **Screws (No.134)** and 4 **Screws (97)**.
5. Install the **Front Stabilizer Cover (No.66)** with 4 **Screws (No.97)**.



CE800ENT CONSOLE OPERATION



STARTING OPERATION

- When the power is turned **ON**, the screen will show a brief loading screen and then display the **Home Screen** which indicates that the machine is ready to operate.

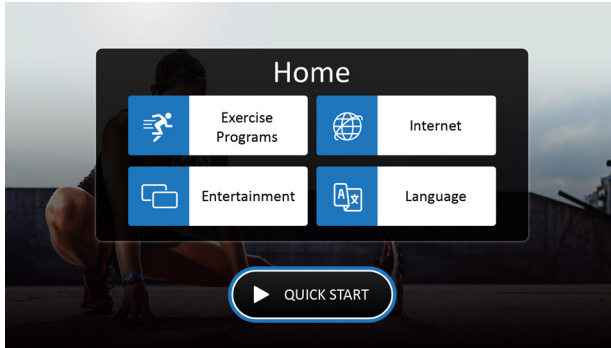

Home Screen: Begin operation by touching the icons.



Quick operating buttons are conveniently located for basic Elliptical functions.

CSAFE FEATURE

Your console is equipped with a CSAFE feature. The Power (POWER) port can be used for powering a remote controlled audio-visual system by connecting a cable from the remote to the Power port at the back of the console. The Communication port (COMM) can be used to interact with fitness software applications.

FUNCTIONS OF THIS ELLIPTICAL

The Touchscreen is used for operating all functions. You can directly touch any button on the screen or through the physical buttons below the console to control functions. On the lower portion of the console there is the **Start** button to begin the workout, **Stop** button to pause/stop programs, **Level** button to change workload.

QUICK START

This is the quickest way to start a workout. After the console powers up you just press the **Start** button to begin. This will initiate the **Quick Start** mode. In **Quick Start** the Time will count up from zero, all workout data will start to accrue and the workload may be adjusted manually by pressing on the screen or the **Up** and **Down** buttons on lower control panel.

HEART RATE FEATURE

The **Pulse (Heart Rate)** on the screen shows the current value of the heart beats per minute. You must use both left and right stainless steel sensors to pick up your pulse. Pulse values are displayed anytime the computer is receiving a signal from the hand pulse sensors. You may use the hand pulse sensors while in Heart Rate Control. The CE800ENT will also pick up wireless heart rate transmitters that are Polar and Bluetooth compatible.

TOUCHSCREEN OPERATION

LANGUAGE

There are 13 languages to choose from. Select your desired language by tapping it on the screen. Once selected, the system will return to the **Home Screen** with your new language being used. To return to the **Home Screen** without selecting a new language, press the **Home** button in the upper left corner of the screen.



INTERNET

The **Internet** section offers various streaming, news, and social media options. The machine must be connected to the internet in order for the apps to work. Simply click on the app of your choice to connect. Follow any on-screen prompts to continue login or other authorizations as needed.

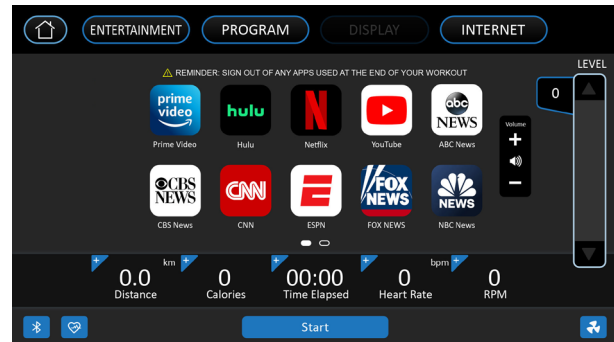

ENTERTAINMENT OPTIONS

From the **Home Screen**, tap **Entertainment** to go to the entertainment menu. You will be given the options of **Screen Mirroring** and **TV mode** interface.

TV Mode

When properly connected to the Set-Top Box (STP) via the HDMI port and **TV mode** selected, you can enjoy TV programs after selecting **TV mode** from the **Entertainment** screen on your Elliptical.

Once **TV mode** has begun:

- Use the ▲ /▼ buttons on the right hand side of the touchscreen to switch between channels.
- Use the +/- volume buttons on the right hand side of the touchscreen to control the sound volume level.
- Tap the “⌂” button to display the media in full screen mode. To resume to normal screen size, simply tap the “⌂” button again to minimize the screen view back to normal size.
- Use the on-screen or physical **Resistance** controls to make updates to your workout while in **TV mode**.
- To **Pause**, press the **Stop** button once.
- To end your workout, press the **Stop** button twice to

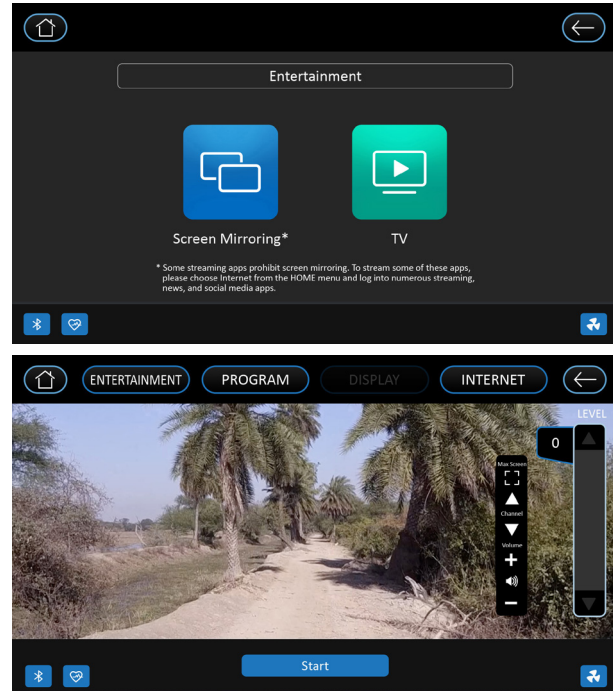

show the workout summary. Pressing the **Stop** button a third time will return you to the **Home Screen**.

SCREEN MIRRORING

When **Screen Mirroring** is selected from the **Entertainment** screen, you may begin pairing your device.

iOS

Screen Mirroring displays your phone's screen on the touchscreen of the Elliptical. Please note that your device must be running iOS 8 or higher.

1. Connect your phone or tablet to the facility's WiFi.
2. Find and select the **Screen Mirroring** button on your phone or tablet by swiping up from your phone's main screen or by swiping down from the top left corner of the screen if you have a newer iOS installed.

Note: When using an iOS device for **Screen Mirroring**, your Bluetooth headphones must be connected to the console.

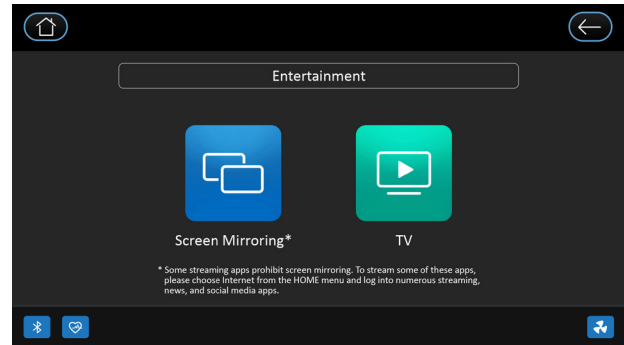

SCREEN MIRRORING

Android

Screen Mirroring displays your phone's screen on the touchscreen of the Elliptical.

1. Connect your phone or tablet to the facility's WiFi.
2. Scan the QR code or search for "Spirit Mirroring" in the Google Play store on your phone or tablet.
3. Download the app.
4. Open the Spirit Mirroring App and select the device name. Then, click **Start Mirroring** to complete the screen mirroring process.
Note: When using an Android device for Screen Mirroring, your Bluetooth headphones must be connected to the your device.

ENTERING A PROGRAM & CHANGING SETTINGS

When the **Exercise Programs** button is selected from the **Home Screen**, the screen displays a menu of the different programs available: **Manual, Hill, Fat Burn, Cardio, HIIT, Interval, Heart Rate, Custom, Constant Power,** and **Fitness Test**. To select and start a preset program:

1. Select a program by tapping it on the screen, then press **Enter** to begin. Customize the program on the following screens by entering your data, or press the **Start** button to begin the program using the default settings.
3. Press the **Start** button to begin your workout, or press the **Stop** button to return to the previous screen.

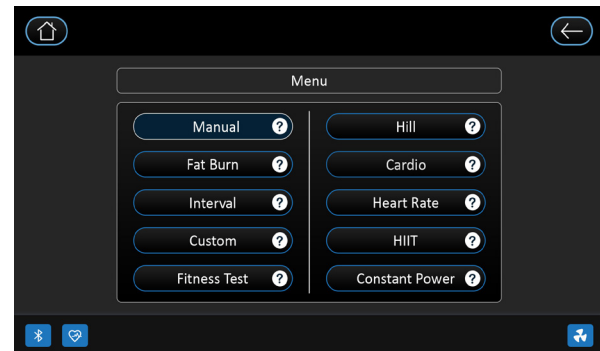
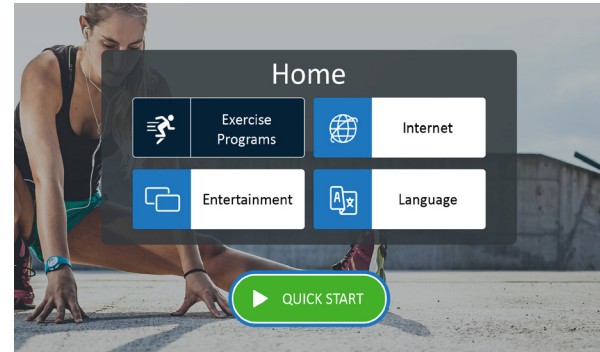

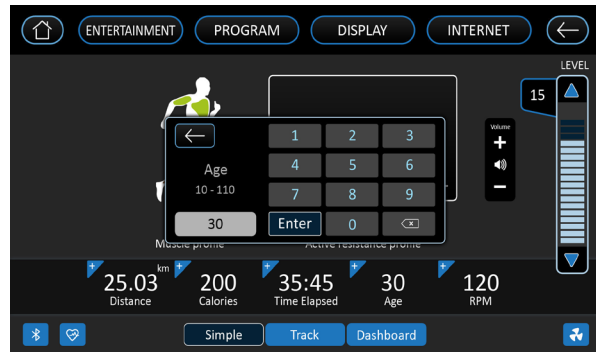
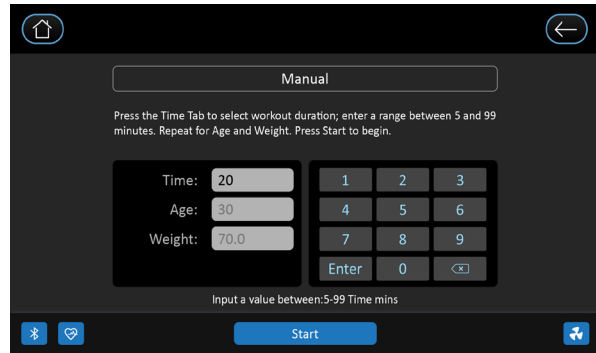

EXERCISE PROGRAM

CHANGING THE WORKOUT DISPLAY

During your workout, you may change the display based on the view that works best for your needs. Once your workout begins, you will see 3 preset views available at the bottom of the screen: **Simple**, **Track**, and **Dashboard**.

SIMPLE

To switch the display to **Simple** view, simply tap the **Simple** button at the bottom of the screen. This view shows a muscle activation profile for the current workout, an overview of the Resistance profile, as well as the elapsed **Distance**, **Calories/Hr**, **Total Time**, **Heart Rate**, and **RPM** as well as other exercise data.

TRACK

To switch the display to **Track** view, simply tap the **Track** button at the bottom of the screen. This view shows a virtual track that corresponds with the current workout, as well as the elapsed **Distance**, number of **Laps**, **Calories**, **Total Time**, **Heart Rate**, and **RPM** as well as other exercise data.

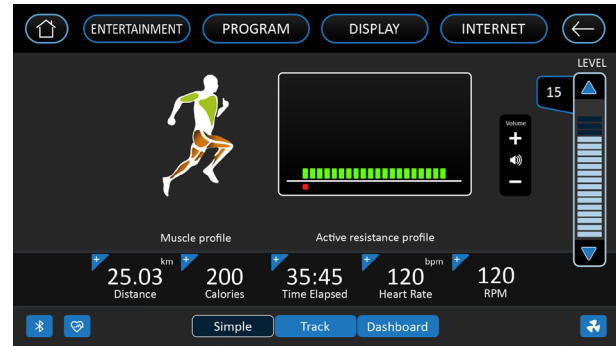

EXERCISE PROGRAM

DASHBOARD

To switch the display to **Dashboard** view, simply tap the **Dashboard** button at the bottom of the screen. This view shows a virtual dashboard mimics a typical Elliptical display with information that corresponds with the current workout. Metrics such as elapsed **Distance**, **Calories/Hr**, **Calories**, **Total Time**, **Heart Rate**, and **RPM** are displayed as well as other exercise data.

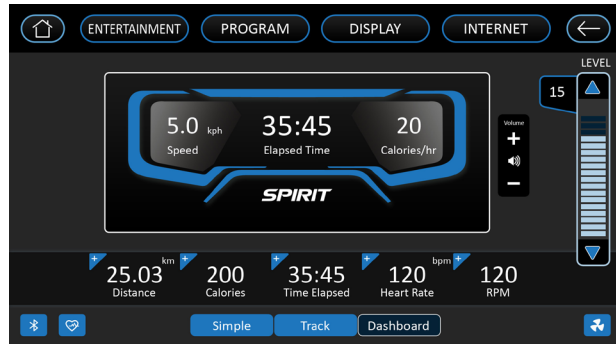

MANUAL

The level of resistance is controlled by the user. Increase or decrease levels at any time during your workout.

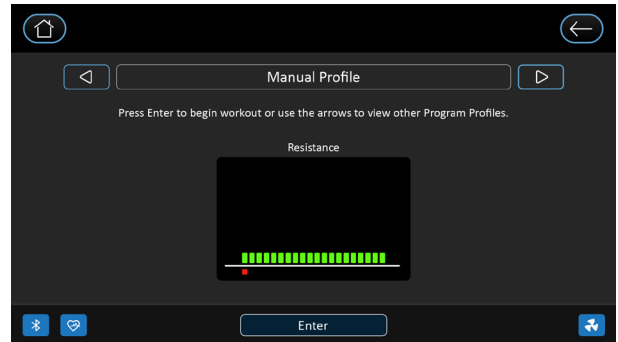
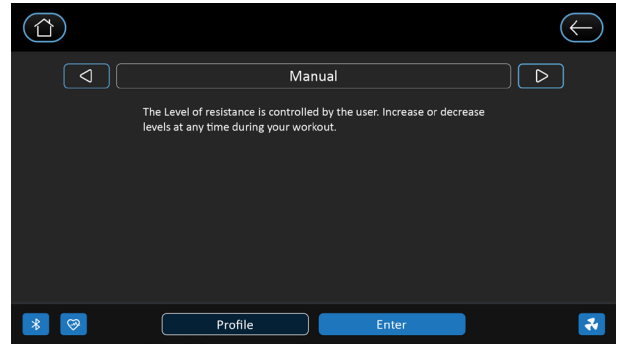

HILL

This program follows a triangle or pyramid type of gradual progression from approximately 10% of maximum effort (the level that you chose before starting this program) up to a maximum effort which lasts for 10% of the total workout time, then a gradual regression of resistance back to approximately 10% of maximum effort.

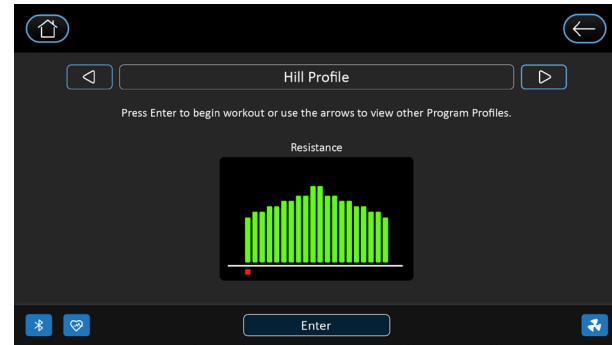

FAT BURN

This program follows a quick progression up to the maximum resistance level (default or user input level) that is sustained for 2/3 of the workout. This program will challenge your ability to sustain your energy output for an extended period of time.

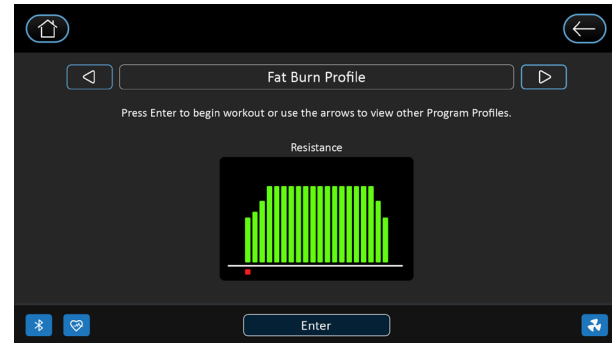

CARDIO

This program presents a quick progression up to near maximum resistance level (default or user input level). It has slight fluctuations up and down to allow your heart rate to elevate, and then recover repeatedly, before beginning a quick cool down. This will build up your heart muscle and increase blood flow and lung capacity.

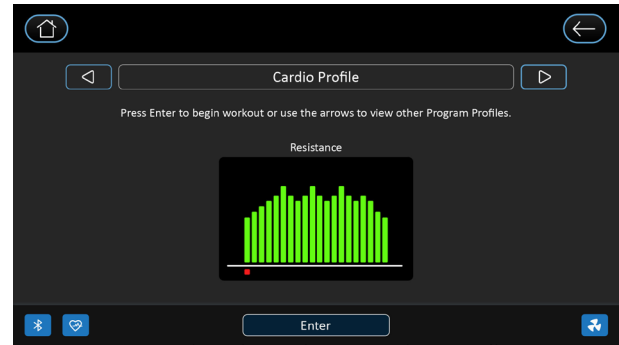

INTERVAL

This program takes you through high levels of intensity followed by recovery periods of low intensity. This program utilizes and develops your fast twitch muscle fibers which are used when performing tasks that are intense and short in duration. These deplete your oxygen level and spike your heart rate, followed by periods of recovery and heart rate drop to replenish oxygen. Your cardiovascular system gets programmed to use oxygen more efficiently.

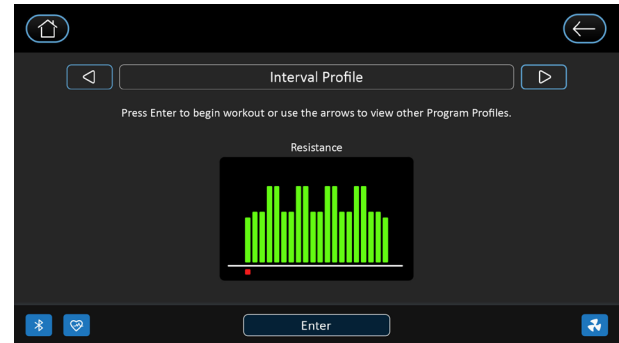

CONSTANT POWER

A watts program is a controllable constant power whose level adjusts when the speed is changed. Choose either faster pedalling at a lower resistance level or slower pedaling at a higher resistance level.

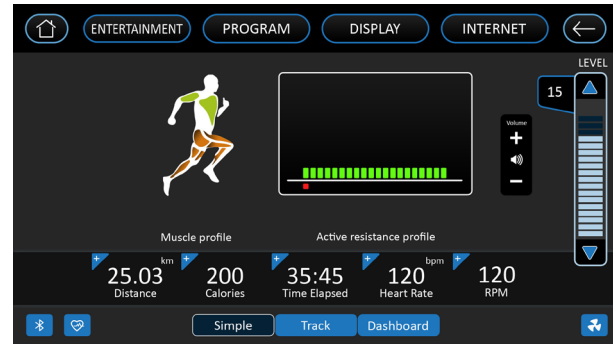

HEART RATE

The default value is 65% of your projected rate maximum. You have the option of changing your target heart rate. The machine will attempt to keep you within five beats of your target heart rate.

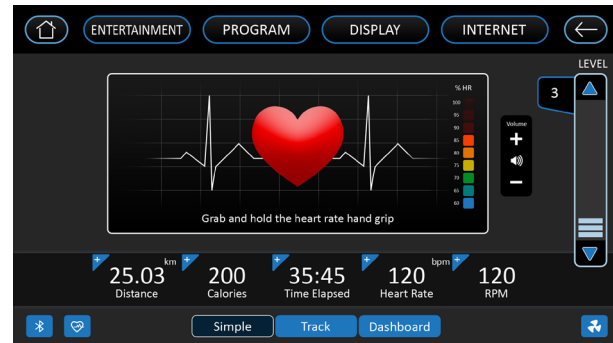

CUSTOM

You will create the desired resistance levels for each of the 20 segments of the program using the keyboard on the screen. You may change these levels at any time during the workout.

TO BEGIN A CUSTOM PROGRAM:

1. Select the **Custom** program then press the **Enter** key to begin customizing the program with your personal data, or just press the **Start** key to begin the program with the default settings.
2. The window will show the corresponding level profile, use the on-screen interface to achieve desired workout profiles. Once complete, press **Next** to save and continue.
3. The following screens will ask you to enter the desired **Time**, the user **Age**, and **Weight**. You may use the default values, or adjust as needed. Press **Start** once complete to begin your new custom workout program!

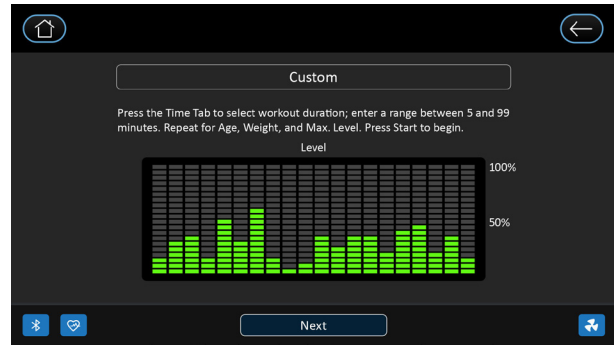

HIIT PROGRAM

The **HIIT**, or **High Intensity Interval Training**, program takes advantage of the latest trend in fitness. During the program you will perform short bursts of high intensity sprinting followed by short rest periods. HIIT is a fully customizable interval training program. You can enter the number of intervals, time of each interval Sprint and Rest periods and the work intensity of the levels.

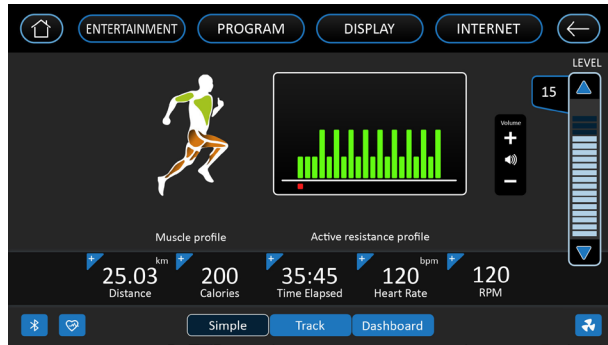

1. Select a program then press the **Enter** key to begin customizing the program with your personal data, and you are asked for and the number of intervals you want to do. The default is 10 and the range available is 3 to 15. One interval equals 1 Sprint and 1 Rest segment.
2. Next is entering the **Interval** time, **Sprint** time and **Rest** time. You may to select the **Sprint** time or **Rest** time from 20 to 90 seconds. After the interval time is set, set the intensity training to **Sprint** level and **Rest** level. This is the resistance level you will experience during HIIT program workout.
3. You may now press **Start** to begin the HIIT program after to adjust the level. The program starts with a 3-minute warm-up period with the resistance level set to 50% of the sprint speed selected previously. You can manually adjust the resistance level during warm-up if you wish.

FITNESS TEST

The VO2 program is based on the YMCA protocol and is a sub-maximal test that uses pre-determined, fixed work levels that are based on your heart rate readings as the test progresses. The test will take anywhere between 6 to 15 minutes to complete, depending on your level of fitness. The test ends when your heart rate reaches 85% of maximum at any time during the test or your heart rate is between 110 bpm and 85% at the end of two consecutive stages. At the end of the test a VO2max score will be given. VO2max stands for Volume of Oxygen uptake which is a measurement of how much oxygen you need to perform a known amount of work. The YMCA protocol uses two to four, 3 minute stages of continuous exercise (see charts below). You will be asked to choose either, Male or Female at the beginning of the test.

This choice determines which test parameters will be used during the test as shown in the charts below.

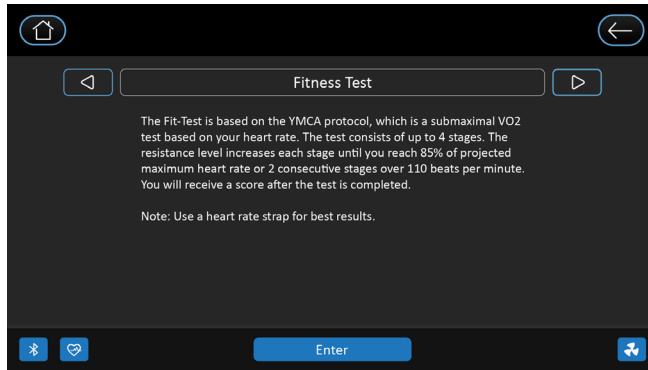

Workload Chart For Male Or Very Fit Female:

1st Stage				300 kgm/min					
HR		< 90			90 - 105				> 105
2nd Stage		500 kgm/min			750 kgm/min			600 kgm/min	
HR	HR <120	HR 120-135	HR >135	HR <120	HR 120-135	HR >135	HR <120	HR 120-135	HR >135
3rd stage	1350 kgm/min	1200 kgm/min	1050 kgm/min	1200 kgm/min	1050 kgm/min	900 kgm/min	1050 kgm/min	900 kgm/min	750 kgm/min

Workload Chart For Female Or De-Conditioned Male

1st Stage				150 kgm/min
Heart Rate	HR<80	HR: 80-90	HR: 90-100	HR>100
2nd Stage	750 kgm/min	600 kgm/min	450 kgm/min	300 kgm/min
3rd Stage	900 kgm/min	750 kgm/min	600 kgm/min	450 kgm/min
4th Stage	1050 kgm/min	900 kgm/min	700 kgm/min	600 kgm/min

Before the Test:

- Make sure you are in good health; check with your physician before performing any exercise if you are over the age of 35 or persons with pre-existing health conditions.
- Make sure you have warmed up and stretched before taking the test.
- Do not take in caffeine before the test.
- Hold the hand grips gently, do not tense up.

During the Test

- The console must be receiving a steady heart rate for the test to begin. You may use the hand pulse sensors or wear a heart rate chest strap transmitter.
- You must maintain a steady 50 rpm pedal speed. If your pedal speed drops below 48 rpm or goes above 52 rpm the console will emit a steady beeping sound until you are within this range.
- You may scroll through the various data readings by pressing the Display button under the Message Window.

- The Message Window will always display your pedal speed on the right side to help you maintain 50 rpm.
- The data shown during the test is:
 1. Work in KGM is actually an abbreviated form of kg-m/min. which is a work measurement of kilogram-force meter/minute
 2. Work in Watts (1 watt is equal to 6.11829727787 kg-m/min.)
 3. HR is your actual heart rate; TGT is the target heart rate to reach to end the test.
 4. Time is the total elapsed time of the test.

After The Test:

- Cool down for about one to three minutes.
- Take note of your score because the console will automatically return to the start-up mode after a few minutes.

What Your Score Means:

VO2MAX CHART FOR MALES AND VERY FIT FEMALES

	18-25 years old	26-35 years old	36-45 years old	46-55 years old	56-65 years old	65+ years old
excellent	>60	>56	>51	>45	>41	>37
good	52-60	49-56	43-51	39-45	36-41	33-37
above average	47-51	43-48	39-42	35-38	32-35	29-32
average	42-46	40-42	35-38	32-35	30-31	26-28
below average	37-41	35-39	31-34	29-31	26-29	22-25
poor	30-36	30-34	26-30	25-28	22-25	20-21
very poor	<30	<30	<26	<25	<22	<20

VO2MAX CHART FOR FEMALES AND DECONDITIONED MALES

	18-25 years old	26-35 years old	36-45 years old	46-55 years old	56-65 years old	65+ years old
excellent	56	52	45	40	37	32
good	47-56	45-52	38-45	34-40	32-37	28-32
above average	42-46	39-44	34-37	31-33	28-31	25-27
average	38-41	35-38	31-33	28-30	25-27	22-24
below average	33-37	31-34	27-30	25-27	22-24	19-22
poor	28-32	26-30	22-26	20-24	18-21	17-18
very poor	<28	<26	<22	<20	<18	<17

RATE OF PERCEIVED EXERTION

There are more variables involved in how hard you should workout than just heart rate. Your stress level, physical health, emotional health, temperature, humidity, the time of day, the last time you ate and what you ate, all contribute to the intensity at which you should workout.

The rate of perceived exertion (RPE), also know as the Borg scale, was developed by Swedish physiologist G.A.V. Borg. The scale helps users determine an approximate heart rate level when a heart rate monitor was not in use. Using the scale below, rate the level of intensity of your workout, or the perception of your effort during your workout. Once the rating has been determined, simply add a "0" to the rating to get your approximate heart rate. For example, if your workout felt comfortable, you would rate it a "12". Then add a "0" to get an approximate heart rate during your workout of 120 beats per minute. The scale is as follows:

Rating Perception of Effort

6 Minimal	10 Very light +	14 Somewhat hard +	18 Very hard +
7 Very,very light	11 Fairly light	15 Hard	19 Very,very hard
8 Very,very light +	12 Comfortable	16 Hard +	20 Maximal
9 Very light	13 Somewhat hard	17 Very hard	

TARGET HEART RATE

The old motto, “no pain, no gain”, is a myth that has been overpowered by the benefits of exercising comfortably. A great deal of this success has been promoted by the use of heart rate monitors. With the proper use of a heart rate monitor, many people find that their usual choice of exercise intensity was either too high or too low and exercise is much more enjoyable by maintaining their heart rate in the desired benefit range.

To determine the benefit range in which you wish to train, you must first determine your Maximum Heart Rate. This can be accomplished by using the following formula: 220 minus your age. This will give you the Maximum Heart Rate (MHR) for someone of your age. To determine the effective heart rate range for specific goals you simply calculate a percentage of your MHR. Your Heart rate training zone is 50% to 90% of your maximum heart rate. 65% of your MHR is the recommended for burning fat while 85% is recommended for strengthening the cardio vascular system. This 65% to 85% is the zone to stay in for maximum benefit.

For someone who is 40 years old their target heart rate zone is calculated:

$220 - 40 = 180$ (maximum heart rate)

$180 \times .65 = 117$ beats per minute (65% of maximum)

$180 \times .85 = 153$ beats per minute (85% of maximum)

So for a 40 year old the training zone would be 117 to 153 beats per minute.

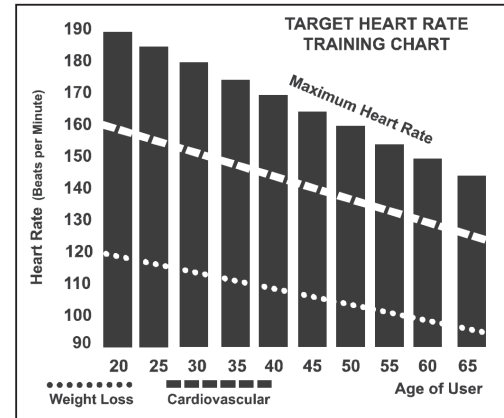

If you enter your age during programming the console will perform this calculation automatically. Entering your age is used for the Heart Rate programs. After calculating your MHR you can decide upon which goal you would like to pursue.

The two most popular reasons for, or goals, of exercise are cardiovascular fitness (training for the heart and lungs) and weight control. The black columns on the chart represent the MHR for a person whose age is listed at the bottom of each column. The training heart rate, for either cardiovascular fitness or weight loss, is represented by two different lines that cut diagonally through the chart. A definition of the lines' goal is in the bottom left-hand corner of the chart. If your goal is cardiovascular fitness or if it is weight loss, it can be achieved by training at 85% or 65%, respectively, of your MHR on a schedule approved by your physician. Consult your physician before participating in any exercise program.

With all Spirit Fitness Ellipticals you may use the heart rate monitor feature without using the Heart Rate program. However, when using the heart rate monitor feature in conjunction with the Heart Rate programs, the machine will automatically adjust resistance to maintain the desired heart rate.

WEARING THE CHEST STRAP (SOLD SEPARATELY)

1. Attach the transmitter to the elastic strap using the interlocking button.
2. Adjust the strap as tightly as possible while ensuring it is still comfortable.
3. Position the transmitter with the logo centered in the middle of your torso facing away from your chest (some people must position the transmitter slightly left of center). Attach the final end of the elastic strap by inserting the round end and, using the locking parts, secure the transmitter and strap around your chest.
4. Position the transmitter directly below the pectoral muscles.
5. Sweat is the best conductor to measure very minute heart beat electrical signals. However, plain water can also be used to pre-wet the electrodes (2 ribbed oval areas on the reverse side of the belt and both sides of the transmitter). It's also recommended that you wear the transmitter strap a few minutes before your work out. Some users, because of body chemistry, have a more difficult time in achieving a strong, steady signal at the beginning. After "warming up", this problem lessens.
6. Your workout must be within range - distance between transmitter/receiver – to achieve a strong steady signal. The length of range may vary somewhat but generally stay close enough to the console to maintain good, strong, reliable readings. Wearing the transmitter directly on bare skin assures you of proper operation. If you wish, you may wear the transmitter over a shirt. To do so, wet the areas of the shirt that the electrodes will rest upon.

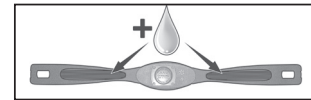

Note: The transmitter is automatically activated when it detects activity from the user's heart. Additionally, it automatically deactivates when it does not receive any activity. Although the transmitter is water resistant, moisture can have the effect of creating false signals, so you should take precautions to completely dry the transmitter after use to prolong battery life (estimated transmitter battery life is 2500 hours). The replacement battery is CR2032. The chest strap is sold separately. Chest straps that operate using Bluetooth should also work with this machine.

ERRATIC OPERATION

Caution! Do not use this Elliptical for Heart Rate programs unless a steady, solid Actual Heart Rate value is being displayed. High, wild, random numbers being displayed indicate a problem.

Areas to look for interference which may cause erratic heart rate:

1. Elliptical is not properly grounded.
2. Microwave ovens, TV's, small appliances, etc.
3. Fluorescent lights.
4. Some household security systems.
5. Electric fence for a pet.
6. Some people have problems with the transmitter picking up a signal from their skin. If you have problems try wearing the transmitter upside down. Normally the transmitter will be oriented so the Spirit Fitness logo is right side up.
7. The antenna that picks up your heart rate is very sensitive. If there is an outside noise source, turning the whole machine 90 degrees may de-tune the interference.
8. Another Individual wearing a transmitter within 3' of your machine's console.

If you continue to experience problems contact your dealer.

GENERAL MAINTENANCE

Wipe down all areas in the sweat path with a damp cloth after each workout. If a squeak, thump, clicking or rough feeling develops the main cause is most likely one of two reasons:

1. The hardware was not sufficiently tightened during assembly. All bolts that were installed during assembly need to be tightened as much as possible. It may be necessary to use a larger wrench than the one provided if you cannot tighten the bolts sufficiently. It is important to note that 90% of calls to the service department for noise issues can be traced to loose hardware.
2. The crank arm nut needs to be retightened. If squeaks or other noises persist, check that the unit is properly leveled. There are 2 leveling pads on the bottom of the rear stabilizer, use a 14mm wrench (or adjustable wrench) to adjust the levelers.

SANITIZING YOUR SPIRIT FITNESS EQUIPMENT

- Upholstered high-contact surfaces (hard plastics) can be sanitized using a 75% isopropyl alcohol solution and a clean, dry cloth. Spray surfaces to be sanitized, and use the dry cloth to wipe clean. Allow surfaces to dry before using.
- For upholstered or soft-plastic surfaces, use a conditioner after sanitizing. Be sure to follow the instructions provided by the conditioner manufacturer to ensure proper use of the conditioner.
- Alternatively, you can make your own spray by mixing the proper ratio of isopropyl alcohol and distilled water to reach a 75% solution.

ELLIPTICAL WARRANTY EFFECTIVE JANUARY 18, 2024

Spirit Fitness warrants all its Elliptical parts for a period of time listed below from the date of retail sale, as determined by sale receipt, or in the absence of a sales receipt eighteen (18) months from the original factory shipping date. Spirit Fitness' responsibilities include providing new or remanufactured parts, at Spirit Fitness' option, and technical support to our independent dealers and servicing organizations. In the absence of a dealer or service organization, these warranties will be administered by Spirit Fitness directly to a facility. The warranty period applies to the following components:

WARRANTY	FRAME	EMS BRAKE	PARTS	LABOR	CONSOLE PARTS	CONSOLE LABOR
Commercial (Non-Dues Paying Facilities)	Lifetime	5 Years	5 Years	2 Years	3 Years	1 Year
Residential	Lifetime	10 Years	10 Years	2 Years	3 Years	1 Year

*Prisons and correctional facilities are excluded from warranty coverage.

NORMAL RESPONSIBILITIES OF THE FACILITY

The non-dues paying facility is responsible for the items listed below:

1. The warranty registration card must be completed and returned to the address listed on the card within 10 days of the original purchase, or completed online to validate the manufacturer's limited warranty.
2. Proper use of the fitness equipment in accordance with the instructions provided in this manual
3. Proper installation in accordance with instructions provided with the fitness equipment and with all local electric codes.
4. Proper connection to a grounded power supply of sufficient voltage, replacement of blown fuses, repair of loose connections or defects in house or facility wiring.
5. Expenses for making the fitness equipment accessible for servicing, including any item that was not part of the fitness equipment at the time it was shipped from the factory.
6. Damages to the fitness equipment finish during shipping, installation or following installation.
7. Routine maintenance of this unit as specified in this manual.

EXCLUSIONS

This warranty does not cover the following:

1. CONSEQUENTIAL, COLLATERAL, OR INCIDENTAL DAMAGES SUCH AS PROPERTY DAMAGE AND INCIDENTAL EXPENSES RESULTING FROM ANY BREACH OF THIS WRITTEN OR ANY IMPLIED WARRANTY.
NOTE: Some states do not allow the exclusion or limitation of incidental or consequential damages, so this limitation or exclusion may not apply to you.
2. Service call reimbursement to the consumer. Service call reimbursement to the dealer that does not involve malfunction or defects in workmanship or material, for units that are beyond the warranty period, for units that are beyond the service call reimbursement period, for fitness equipment not requiring component replacement, or fitness equipment not in non-dues paying facility or household use.
3. Damages caused by services performed by persons other than authorized Spirit Fitness service companies; use of parts other than original Spirit Fitness parts; or external causes such as corrosion, discoloration of paint or plastic, alterations, modifications, abuse, misuse, accident, improper maintenance, inadequate power supply, or acts of God.
4. Products with original serial numbers that have been removed or altered.
5. Products that have been: sold, transferred, bartered, or given to a third party.
6. Products that do not have a warranty registration card on file at Spirit Fitness. Spirit Fitness reserves the right to request proof of purchase if no warranty record exists for the product.
7. THIS WARRANTY IS EXPRESSLY IN LIEU OF ALL OTHER WARRANTIES EXPRESSED OR IMPLIED, INCLUDING THE WARRANTIES OF MERCHANTABILITY AND/OR FITNESS FOR A PARTICULAR PURPOSE.
8. Product used in a dues paying facility (YMCA, Health Club, Etc.)
9. Product used in prisons and correctional facilities
10. Warranties outside of the United States may vary. Please contact your local dealer for details.

SERVICE

Keep your bill of sale. Twelve (12) months from the date on the bill of sale or eighteen (18) months from the date of factory shipping as determined by the serial number establishes the labor warranty period should service be required. If service is performed, it is in your best interest to obtain and keep all receipts. This written warranty gives you specific legal rights. You may also have other rights that vary from state to state. Service under this warranty must be obtained by following these steps, in order:

1. Contact your selling authorized Spirit Fitness dealer. OR
2. Contact your local authorized Spirit Fitness service organization.

4. Spirit Fitness' obligation under this warranty is limited to repairing or replacing, at Spirit Fitness' option, the product through one of our authorized service centers. All repairs must be preauthorized by Spirit Fitness. If the product is shipped to a service center freight charges to and from the service center will be the customer's responsibility. For replacement parts shipped while the product is under warranty, the customer will be responsible for shipping and handling charges. For in-home service, the customer will be responsible for a trip charge. There will be an additional trip charge if the customer is located over 100 miles from the nearest service center.
5. The owner is responsible for adequate packaging upon return to Spirit Fitness. Spirit Fitness is not responsible for damages in shipping. Make all freight damage claims with the appropriate freight carrier. DO NOT SHIP ANY UNIT TO OUR FACTORY WITHOUT A RETURN AUTHORIZATION NUMBER. All units arriving without a return authorization number will be refused.

Product features or specifications as described or illustrated are subject to change without notice. All warranties are made by Spirit Manufacturing, Inc. This warranty applies only in the 48 contiguous United States. NOTE: This does not apply to Alaska or Hawaii.

CE800ENT Part List		
1	Main Frame	1
2	Rear Rail Assembly	1
3	Rail Support Assembly	1
4	Cross Bar	2
5	Pedal Arm (L)	1
6	Pedal Arm (R)	1
7	Connecting Arm (L)	1
8	Connecting Arm (R)	1
9	Swing Arm (L)	1
10	Swing Arm (R)	1
11	Console Mast	1
12	Crank Axle	1
13	Idler Wheel Assembly	1
21	6005 Bearing	10
23	6203 Bearing	6
24	6003 Bearing	8
25	M14 x P2.0 Rod End Bearing	2
26	Retaining Bracket, Aluminum Track	6
27	Drive Belt	1
28	Drive Pulley	1
29	Flywheel	1
30	Magnet	1
31	Console Assembly	1
32	500mm Sensor W/Cable	1
33	300mm Wire Brake Coil Harness(Red)	1
34	600mm Connecting Wire(Black)	1
35	600mm Connecting Wire(White)	1
36	700mm Computer Cable	1
37	150mm Connecting Wire(Black)	1
38	150mm Connecting Wire(White)	1
39	150mm Connecting Wire,Power Cord	1
40	850mm Handpulse W/Cable Assembly(XHP-3)	1
41	850mm Handpulse W/Cable Assembly(XHP-4)	1
43	Power Cord	1

44	EMS Controller	1
45	Power Adaptor	1
47	AC Electronic Module	1
48	80mm Connecting Wire (White)	1
49	80mm Connecting Wire (Black)	1
50	200mm Ground Wire	1
51	Board	1
53	Transfer board	1
56	Ø72 Slide Wheel , Urethane	4
57	Rubber Foot	4
58	Chain Cover (L)	1
59	Chain Cover (R)	1
60	Round Disk	2
61	Round Disk Cover	2
62	TPR Handle Bar Axle Inner Cover	2
63	Beam Cover	1
64	Pedal Arm Cover (L)	1
65	Pedal Arm Cover (R)	1
66	Front Stabilizer Cover	1
67	Pedal (L)	1
67-1	Pedal Foam (R)	1
68	Pedal (R)	1
68-1	Pedal Foam (L)	1
69	Slide Wheel Cover	2
70	Ø32(1.8T) Button Head Plug	2
71	Pedal End Cover	2
72	Connecting Arm Cover A (R)	2
73	Connecting Arm Cover A (L)	2
74	Connecting Arm Cover B (R)	2
75	Connecting Arm Cover B (L)	2
76	Front Handle Bar Cover (L)	1
77	Rear Handle Bar Cover (L)	1
78	Front Handle Bar Cover (R)	1
79	Rear Handle Bar Cover (R)	1
80	Console Mast Cover (L)	1
81	Console Mast Cover (R)	1

82	Ø25 × Ø25 × 1.5T Rubber Foot Pad	2
83	Rear Stabilizer Cover (A)	2
84	Rear Stabilizer Cover (B)	2
85	Aluminum Axle End Cap	2
88	Aluminum Track	2
89	Support Aluminum Cover	1
90	Idler Bolt Bearing	3
91	Transportation Wheel	2
92	M4 × 5T Nylon Nut	2
93	M4 × 12mm Phillips Head Screw	2
94	Carriage Bolt	2
95	5/16" × UNC18 × 3/4" Hex Head Bolt	6
96	5/16" × 2" Button Head Socket Bolt	2
97	M5 × 12mm Phillips Head Screw	40
98	1/4" × UNC20 × 3/4" Hex Head Bolt	8
99	Ø25 C Ring	2
100	Ø17 C Ring	5
101	M8 × 9T Nylon Nut	1
102	1/4" × 8T Nylon Nut	4
103	5/16" × 7T Nylon Nut	2
105	Ø3/8" × Ø19 × 1.5T Flat Washer	4
106	Ø5/16" × Ø35 × 1.5T Flat Washer	4
107	Ø5/16" × Ø23 × 1.5T Flat Washer	4
108	M8 × 170mm I Bolt	1
109	Ø17 × 0.3T Wave Washer	12
110	Ø5 × 16L Tapping Screw	6
111	4 × 15mm Sheet Metal Screw	1
112	4 × 19mm Sheet Metal Screw	7
113	5 × 16mm Tapping Screw	16
114	3 × 20mm Tapping Screw	4
115	Ø1/4" × 19mm Flat Washer	17
116	5 × 19mm Tapping Screw	2
117	Ø1/4" × 13 × 1.0T Flat Washer	8
118	Ø1/4" Split Washer	8
119	M6 × 15mm Phillips Head Screw	6
120	5/16" × UNC18 × 5/8" Hex Head Bolt	2
121	7 × 7 × 25mm Woodruff Key	2

122	M8 × 30mm Socket Head Cap Bolt	2
124	5/16" × 12mm Hex Head Bolt	2
125	M14 × 7mm Nut	2
126	5/16" × UNC18 × 15mm Socket Head Cap Bolt	2
127	3/8" × 2-1/4" Button Head Socket Bolt	4
128	3/8" × UNC16 × 3-3/4" Button Head Socket Bolt	6
129	Ø3/8" × 23 × 2.0T Curved Washer	6
130	Ø3/8" × Ø19 × 1.5T Flat Washer	4
131	M5 × 10mm Phillips Head Screw	8
132	M8 × 25mm Socket Head Cap Bolt	4
133	Ø25 Wave Washer	3
134	3.5 × 12mm Sheet Metal Screw	18
135	3/8" × 3/4" Hex Head Bolt	2
136	M10 × 8T Nylon Nut	2
137	M10 × 1.5(14mm) Bolt	2
138	Ø3/8" × 30 × 2.0T Flat Washer	2
139	13/14mm Wrench	1
140	L Allen Wrench	1
141	M12 L Allen Wrench	1
142	14/17mm Wrench	1
143	Phillips Head Screw Driver	1
144	M3 × 10mm Phillips Head Screw	7
148	Control Power Board	1
149	1600mm Communication Cable	1
150	1600mm Csafe Connecting Wire	1
151	1600mm Hdmi Connecting Wire	1
152	1650mm Computer Cable	1
153	Controller Back Plate	1
155	300mm Ground Wire	1
157	M5 Star Washer	1
158	Water Bottle Holder Clamp	1
159	Water Bottle Holder	1
163	Ø5/16" × 23 × 3T Flat Washer	2