

06/17



BROOKFIELD

INSTRUCTIONS FOR USE

Codes 6571 to 6578



CONTENTS	PAGE
1.0 INTRODUCTION	1
2.0 ILLUSTRATION & TECHNICAL DATA	2
3.0 FOR YOUR SAFETY	3
4.0 UNPACKING YOUR CHAIR	4
5.0 SETTING UP AND ADJUSTING YOUR CHAIR	5
6.0 CARE & MAINTENANCE	9
7.0 WARRANTY & SERVICE	13
8.0 CONTINUOUS IMPROVEMENT	13
9.0 SERVICE INSPECTION	14

1.0 INTRODUCTION

Thank you for choosing the Smirthwaite Brookfield Chair.

The Brookfield is a robust chair for children from the age of 2 years old to young adult who require moderate levels of postural support when seated. Its natural wood design means that it fits wells into nursery, school and home environments.

	<p>IMPORTANT!</p> <p>These instructions should be read by all therapists and carers using the equipment and should be retained for future reference. The product should always be used under adult supervision.</p> <p>Any incorrect use of the product and failure to follow the instructions may put the user at risk or impede the function. If you have any queries using this product or wish for further copies, please do not hesitate to contact Customer Service department on T: +44 (0) 1626 835552.</p> <p>This product has been designed and manufactured specifically and solely for use by clients with special needs.</p>
---	---



2.0 ILLUSTRATION OF YOUR CHAIR

- A. Ramped Seat
- B. Contoured Backrest
- C. Armrest
- D. Leg Outrigger
- E. Lapstrap

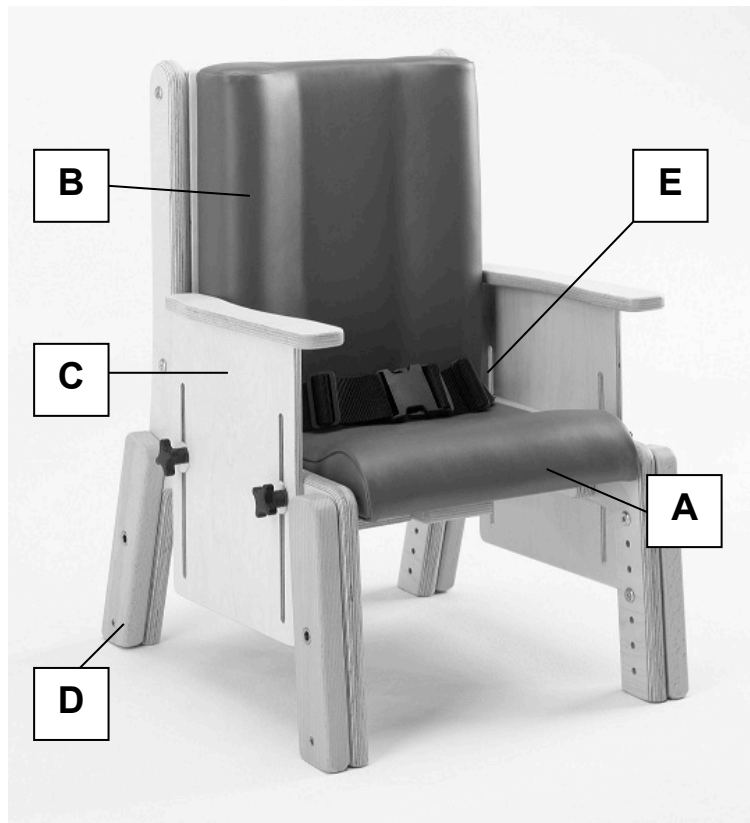

2.1 TECHNICAL DATA

SIZE	1LB	1HB	2LB	2HB	3LB	3HB	4LB	4HB
CODE	6571	6572	6573	6574	6575	6576	6577	6578
Dimension								
Seat Height (mm)	255-330	255-330	280-380	280-380	345-445	345-445	425-575	425-575
Back Height (mm)	365-490	465-585	410-530	495-615	450-590	530-670	505-645	570-710
Width (mm)	325	325	365	365	435	435	435	435
Seat Depth (mm)	220-320	220-320	275-385	275-385	355-465	355-465	425-570	425-570
User Weight (kg)	55	55	65	65	75	75	85	85
Shipping Weight (kg)	12	14	18	20	23	25	28	30



3.0 FOR YOUR SAFETY



STOP!

Please read these instructions CAREFULLY and THOROUGHLY.

- The user should **NOT** be left unattended whilst in the chair. Always ensure a responsible therapist or carer is in attendance.
- If you believe the chair or any fitted accessory to be faulty at any time, **DO NOT USE** – contact Smirthwaite by telephone on +44 (0)1626 835552.
- The therapist should be familiar with the methods of adjustment and have completed all adjustments appropriately to meet the needs of the child before transferring the child onto the chair.
- The chair is **ONLY** to be used indoors on a flat level surface.
- **DO NOT EXCEED USER MAXIMUM WEIGHT LIMITS**
- Always fasten the pelvic strap and any other straps provided with the chair. When Velcro straps are used, the Velcro should overlap by at least 75mm (3 inches).
- Regular maintenance checks and cleaning are essential for the safe use of this equipment (see Section 6.0 Care and Maintenance).
- Always keep this product away from naked flames, cigarettes and sources of heat including open fireplaces, radiators, heaters.
- **DO NOT** fit parts or accessories of other manufacturers to this product unless authorised to do so in writing by Smirthwaite Ltd. Failure to follow these instructions will not only invalidate the guarantee but could make the chair dangerous to use. Smirthwaite Ltd will not accept liability for any injury or damage incurred through such malpractices. Any repairs required must be carried out by Smirthwaite Ltd authorised personnel.





STOP!

LAP STRAPS & HARNESSSES SAFETY NOTICE

Lap straps and harnesses must be appropriate and safe for the user and the users clothing.

Lap straps and harnesses must be checked every time the chair is used to ensure they are fitted as prescribed by the clinician, take account of the users clothing and are tightened so that the user cannot sustain injury.

Checking the fit of lap straps and harnesses must be done with the user in the chair and should be undertaken as soon as the users sits in the chair.

4.0 UNPACKING YOUR CHAIR



STOP!

If in any doubt, ALWAYS seek ADVICE.

Always turn hand wheels, levers and screws clockwise to tighten or anti-clockwise to loosen.

- When delivered, the chair will be supplied fully assembled except for the attachment of any special accessories ordered.
- If your order has been supplied as a custom kit, please ensure you follow both the instructions documented in this IFU **and** any additional instructions supplied.
- Please take note of any instructions on the packaging/box when unpacking.
- Once the chair has been carefully unpacked, please check all parts.



STOP!

If you believe this product to be faulty – DO NOT USE – Contact Smirthwaite Ltd on T: +44 (0) 1626 835552



5.0 SETTING UP AND ADJUSTING YOUR CHAIR



STOP!

If in any doubt, ALWAYS seek ADVICE.

Always turn hand wheels, levers and screws clockwise to tighten or anti-clockwise to loosen.

5.1 ADJUSTMENTS

Adjustments can be made to the seat; depth, seat height and back height

5.1.1 SEAT DEPTH

To move seat forwards or backwards

- Loosen handwheels (A)
- Slide seat to desired position (B)
- Allow 25mm gap between the back of knee and the edge of the seat
- Tighten handwheels (A) when the seat depth is set to the desired position

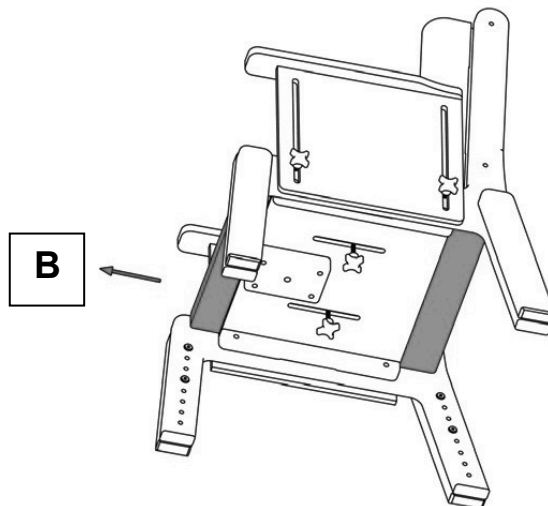
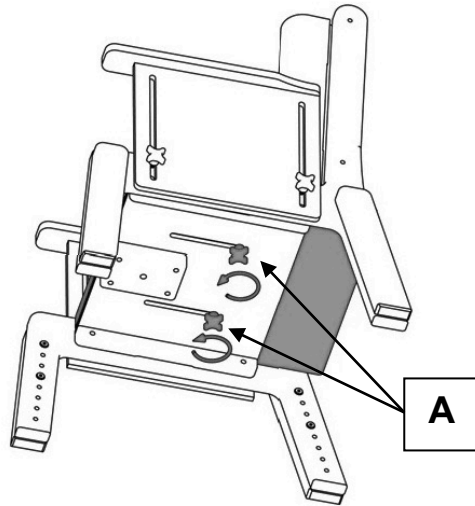

5.1.2 SEAT HEIGHT

- To adjust the seat height, reposition the leg outriggers (A) using the tool provided for this purpose.
- There are 2 screws per leg.
- Ensure the screws are re-inserted and tightened when the desired height is achieved.

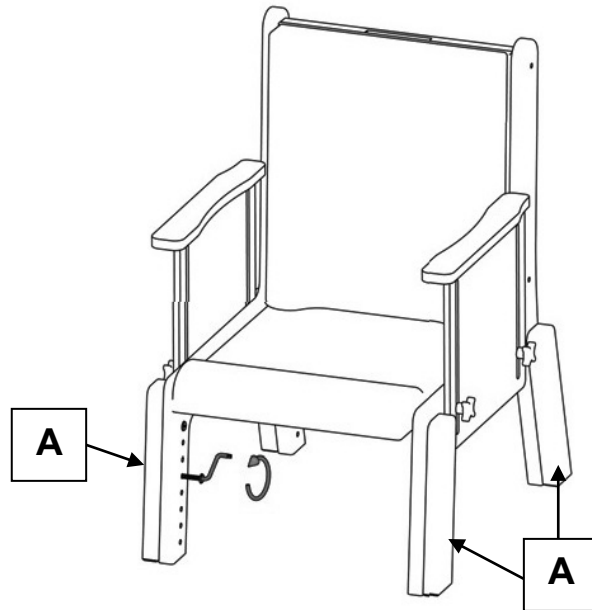

5.1.3 BACK HEIGHT

To adjust the height position of the back cushion

- Loosen handwheels (A)
- Slide back cushion to desired position (B)
- Tighten handwheels (A) when the back cushion is set to the desired position

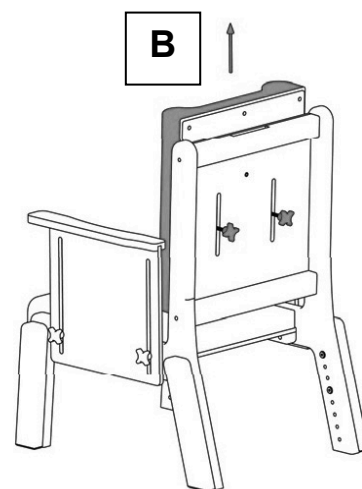
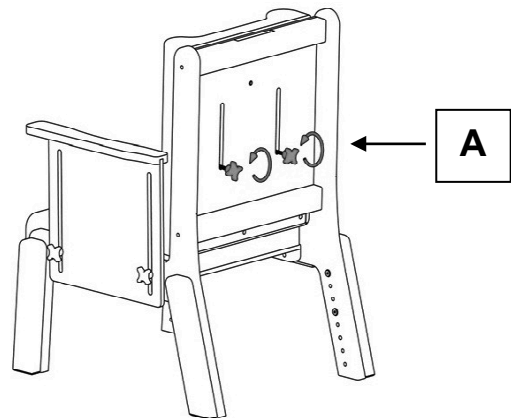

5.1.3 ARMREST HEIGHT ADJUSTMENT

To adjust the height of the armrest

- Loosen handwheels (A)
- Slide armrest to desired position (B)
- Tighten handwheels (A) when the armrest is set to the desired position
- Repeat for both armrests
- Armrests can be lowered to minimum setting to facilitate side transfer of child into the seat.

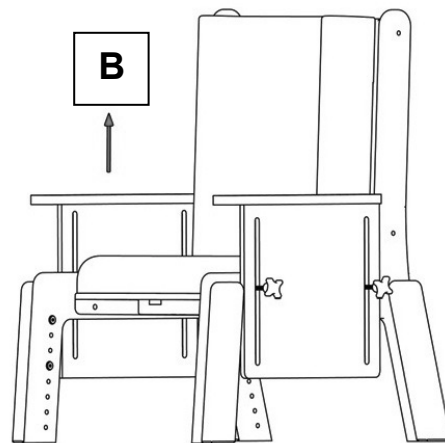
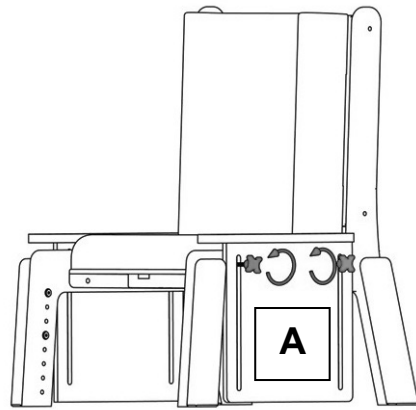

5.1.4 TRAY ACCESSORY

A wooden tray accessory is available for your Brookfield chair.

The tray slides onto the armrests, and toggles (A) are rotated to secure the tray into position.

Ensure the armrests are set to the same height before sliding the tray into place.

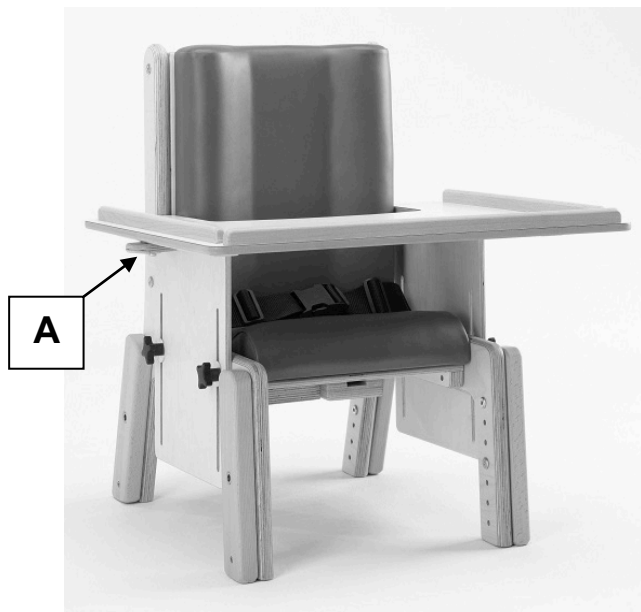

5.1.5 PELVIC STRAP

Buckle Strap (Standard)

- The buckle is secured by pushing (A) into (B).
- To release the buckle, press both sides of (A)
- The strap length can be altered by adjusting the tri-glide (as shown opposite)

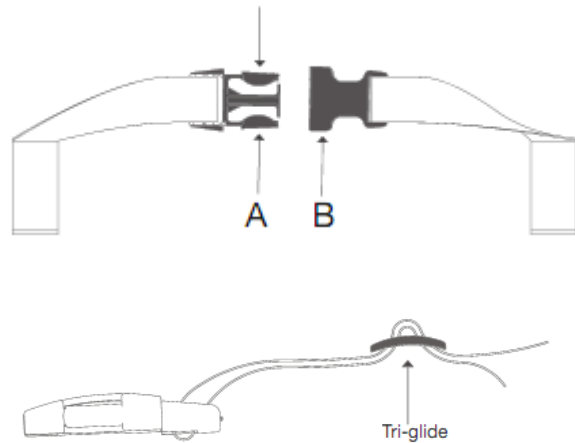

Velcro Strap

- The strap is secured by pressing the two Velcro sections together and is released by pulling the sections apart
- When Velcro straps are used, the Velcro should overlap by at least 75mm (3 inches).

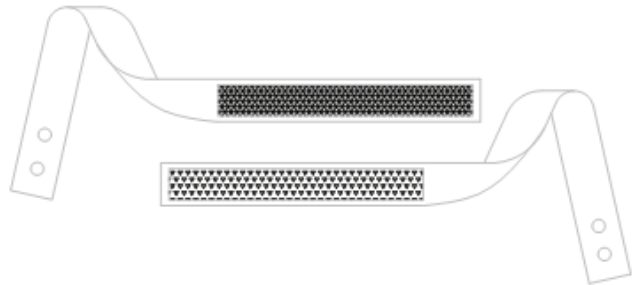

5.1.6 REPLACEMENT STRAPS

- To replace the straps, pull the straps off the popper fasteners, located on the underside of the chair (A)

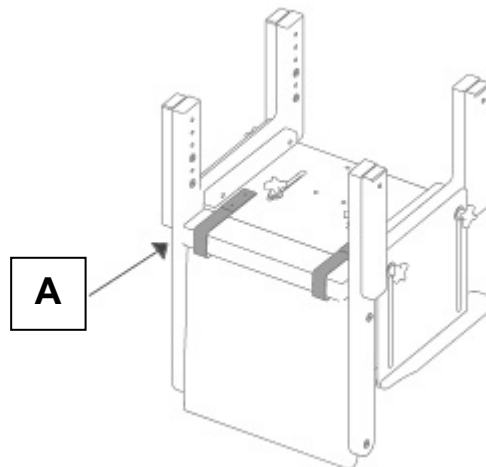

6.0 CARE AND MAINTENANCE



IMPORTANT!

CLEANING IS RECOMMENDED ON A REGULAR BASIS

- Clean upholstery and wooden parts with a damp cloth and mild detergent.
- Stubborn marks on the woodwork should be cleaned by using a soft brush.
- Do not soak or immerse the chair in water.
- The pelvic strap can be cleaned with a damp cloth. In cases of extreme soiling it can be machined washed at low temperature with mild detergent but must be drip dried.
- Store the chair in a cool dry place out of direct sunlight.
- DO NOT use bleach, solvents, abrasives, synthetic detergents, wax polishes, antibacterial sprays or wipes.
- For further information please refer to MHRA or your NHS cleaning guidelines.

6.1 DAILY CHECKS

- Check the tray (if supplied) to ensure no parts are loose or damaged
- Check all upholstery for signs of wear and tear
- Check that the hand wheels tighten correctly, and are not cross-threaded or damaged
- Check that the leg screws are present and are tightened correctly
- Check all straps for fraying, and that buckles are not missing/damaged
- Check the strap is securely fastened to the poppers on the underside of the chair



STOP!

THE USER SHOULD NOT BE SEATED WHILE THE CHECKS ARE CARRIED OUT.

6.2 SERVICE INTERVAL

The Brookfield chair should be serviced every 3 years. Servicing must only be undertaken by a Smirthwaite service engineer, or by a Smirthwaite trained representative.



6.3 NOMINAL SERVICE LIFE

Your product has a nominal service life of 12 years, during which full post-sales support will be available with regard to spares and servicing.

Product service life has been determined based upon the design complexity of product, and the anticipated exposure to normal use.

Good practice dictates all Smirthwaite products have been designed and manufactured to high levels of safety and quality, and will meet requirements of normal use when maintained in line with our servicing recommendations.



STOP!

If the product has been out of use for an extended period of time (6 months or more) it should always be serviced prior to being reissued.

If the product has been subjected to 'heavy' or 'constant' use, the service should be reduced to half the recommended period.

Constant and/or heavy use is considered to be:

- Daily use above 7 hours duration
- Weekly use above 5 days duration
- Monthly use above 10 months per year
- Use by a client who is at 90% to 100% of the maximum weight limit of the product. The maximum weight limit must **NEVER** be exceeded
- Use by a client who is extremely active, either voluntarily or involuntarily



6.4 EXTENDING NOMINAL SERVICE LIFE

At Smirthwaite we are proud to produce products that have a reputation for quality and durability.

We believe our products have the potential to provide benefits to our clients beyond the nominal service life documented above.

We will continue to provide full support beyond the nominal service life provided the following conditions are met:

1. A full service schedule has been maintained.
2. A full service and inspection is undertaken at the end of the nominal service life period
3. The product is subsequently serviced annually (or biannually if under 'heavy/constant' use conditions)
4. Smirthwaite reserve the right to limit support where parts/components are no longer available

6.5 DOCUMENTATION/RECORDS

- It is the responsibility of the current equipment owner to ensure the 'Instructions for Use' manual and any further manuals for accessories fitted to the equipment are handed over to the new owner at the time of exchange/sale
- It is the responsibility of the current equipment owner to ensure the service and inspection record form is kept up to date

6.6 PRODUCT CONFIGURATION

- Smirthwaite will document and maintain a record of the original product configuration at the time of first sale
- Smirthwaite will not be held responsible for any subsequent changes to this configuration unless authorized to do so in writing by Smirthwaite Ltd
- It is the equipment owner's responsibility to maintain their own records of changes to the equipment configuration and to be able to provide such records to subsequent owners to maintain traceability
- We recommend an inspection/service by a Smirthwaite Service Engineer (or Smirthwaite trained engineer) whenever a significant change is made to product configuration to ensure the product is safe to use. **If in any doubt, ALWAYS seek ADVICE**





IMPORTANT REMINDER!

DO NOT fit parts or accessories of other manufacturers to this product unless authorized to do so in writing by Smirthwaite Ltd.

Any servicing or repairs required must be carried out by Smirthwaite Ltd (or a Smirthwaite trained engineer).

If you believe this product to be faulty – DO NOT USE – Contact Smirthwaite Ltd on T: +44 (0) 1626 835552

If in any doubt, ALWAYS seek ADVICE.



7.0 WARRANTY & SERVICE

Smirthwaite Ltd warrants the products detailed on your order to be free from defects in materials and workmanship for a period of 2 years from date of delivery. If a fault develops during the period, please call Customer Services by email or telephone 01626 835552 who will advise you on the best course of action. Possible action may be for us to arrange to send out one of our Service Engineers, or have the goods returned to us. Should a repair not be possible within the guarantee period we will replace the product for new or nearest equivalent product. In the unlikely event that we cannot repair or exchange we will refund in full.

This warranty is for the UK only. The warranty excludes faults due to accident, neglect, misuse, not following the Instructions and normal wear and tear. This warranty is in addition to your legal rights. Goods will only be collected from the original delivery address.

A charge may be made where the goods cannot be repaired under the terms of the warranty. You will be advised before this is made.

T: +44 (0)1626 835552 E: info@smirthwaite.co.uk

8.0 CONTINUOUS IMPROVEMENT

Smirthwaite Ltd are committed to continuous improvement to their product range. Should you have any suggestions or comments please send them to our product design department at: info@smirthwaite.co.uk

Smirthwaite Ltd reserve the right to change the specification or material without prior notice.

For catalogues, help and further information on our products please contact us at:

Smirthwaite Ltd 16 Wentworth Road Heathfield, Devon.TQ12 6TL

T: +44 (0)1626 835552

F: +44 (0)1626 835428

E: info@smirthwaite.co.uk

W: www.smirthwaite.co.uk





Smirthwaite, 16 Wentworth Road, Heathfield, Newton Abbot, Devon.TQ12 6TL
T: +44 (0) 1626 835552 F: +44 (0) 1626 835428 E: info@smirthwaite.co.uk www.smirthwaite.co.uk

