

ACR162GLHD



22.88" x 18.75" x 18" (H x W x D)

Compact healthcare all-refrigerator with self-closing glass door, front lock, digital controls, and external temperature readout

Highlights:

Designed and constructed for reliable cold storage in healthcare facilities

External temperature readout of the current and high/low temperatures

User-friendly front control panel keeps the thermostat and alarm in reach without having to open the door

Product Features:

EQTemp Healthcare Refrigerator	All-refrigerator designed to operate between 2 and 8°C for a variety of storage application in medical offices and other healthcare facilities
Temperature Range: 2° to 8°C	Preset to 5°C as recommended for many storage applications
Compact size	Full 1.58 cu.ft. capacity inside conveniently slim footprint
External temperature readout	Includes continuous display of the current interior and high/low temperature, and can be switched from Celsius to Fahrenheit at the touch of a button
High/low temperature alarm	Audible alarm sounds if the interior temperature rises or falls out of set range
Buffered temperature probe	Thermometer probe is encased in a glass bead-filled bottle and stored in a fixed box on the center shelf. This is the ideal way to produce temperature readings closest to stored contents, as recommended by the CDC and VFC's guidelines
Access port	3/8" probe hole with cover is pre-installed in unit's side to allow easy installation of user-provided monitoring equipment
Factory installed lock	Keyed lock for a secure interior (2 keys included)
Automatic defrost	Reduced user maintenance with automatic defrost

ACR162GLHD Specifications:

Overview	
Height of Cabinet	22.88" (58 cm)
Width	18.75" (48 cm)
Width with Door Open	19.25" (49 cm)
Depth	18.0" (46 cm)
Depth with door at 90°	33.75" (86 cm)
Capacity	1.58 cu.ft. (45 L)
Defrost Type	Automatic
Door	Glass
Cabinet	White
US Electrical Safety	ETL
Canadian Electrical Safety	ETL-C
Amps	0.6
Voltage/Frequency	115 V AC/60 Hz
Weight	49.6 lbs. (22 kg)
Parts & Labor Warranty	1 Year
Compressor Warranty	5 Years
UPC	761101107592
Refrigerator Features	
Door Swing	LHD
Reversible	Factory Reversible
Shelf Type	Wire
Shelf Qty	1
Thermostat Type	Digital
Fan Type	Interior
Refrigerant Type	R600a
Refrigerant Amount	0.85oz.
High Side PSI	1.45
Low Side PSI	0.85
Level Legs Qty	2
Interior Light	Yes
Temperature Range	2° to 8°C
Sound Level	35.4 dB
Dimensions	
Interior Height	16.63" (42 cm)
Interior Width	15.63" (40 cm)
Interior Depth	12.13" (31 cm)
Compressor Step Height	7.75" (20 cm)

Compressor Step Width	15.63" (40 cm)
Compressor Step Depth	5.25" (13 cm)

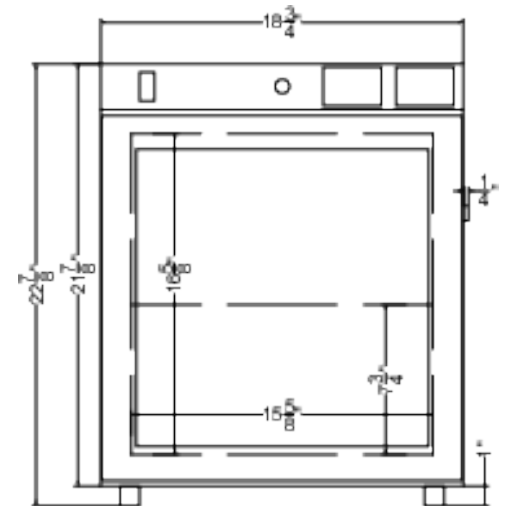
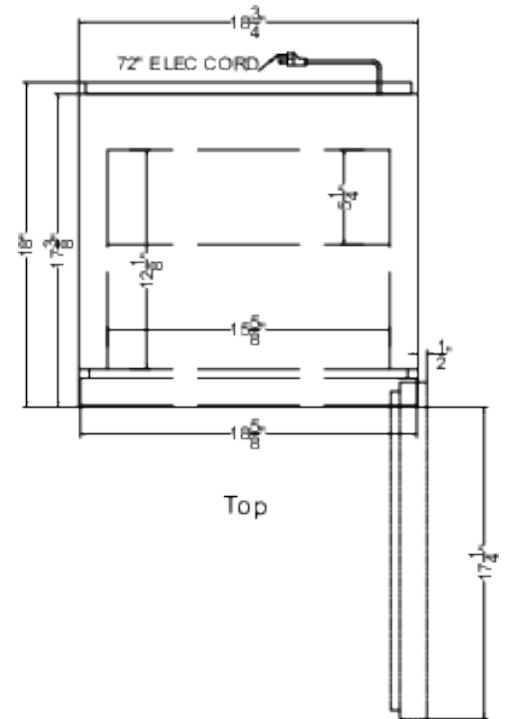

Front