



Model 650-10-1

### Approvals



### Part Number/Price

Part #	Model #	Capacity	Price
161784	650-10-1	0-10 lb × 0.05 oz, 10-33 lb × 0.1 oz (0 to 5 kg × 1 g, 5 to 15 kg × 2 g)	Consult

### Shipping Weight

Part #	Model #	L × W × H	Package Wgt. (lb)	Dim Wgt. (lb)	Shipping Wgt. (lb)
161784	650-10-1	18 × 28 × 11 in	25	40	40

### Options/Accessories

Part #	Description	Price
165138	AC adaptor, input voltage 100-240V, c-Met, medical grade	Consult

### Dimensions

	Inches	Centimeters
A	24.0	60.8
B	19.0	48.2
C	6.75	17.1
D	17.0	43.2

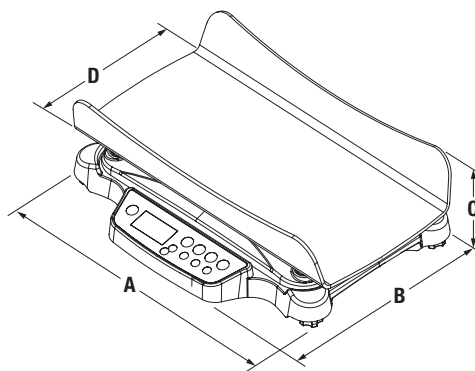

### Standard Features

- LCD display
- Dual-range capacity for increased precision
- Unit of measure locking
- Automatic shut-off for long battery life
- Motiontrap™ movement compensation technology
- Built-in measuring tape

### Specifications

#### Capacity:

Range 1: 0 to 10 lb × 0.05 oz (0 to 5 kg × 1 g)  
Range 2: 10 to 33 lb × 0.1 oz (5 to 15 kg × 2 g)

#### Power:

12 VDC, provided by six AA lithium batteries (included) or AC adaptor (optional)

#### Measuring Tape:

0 to 23.5 in × 0.125 in  
(0 to 60 cm × 0.25 cm)

#### Battery Type:

Six Li-FeS<sub>2</sub> batteries

#### Operating Temperature:

50 °F to 95 °F (10 °C to 35 °C)

#### Display:

5-digit LCD display, 0.75 in (1.9 mm) digit height

#### Approvals:

c-Met E113986

#### Warranty:

Two-year limited