



# Operating Manual

## Aspire Pediatric Glider Models:

100-PS

100-PM

100-PL



**Distributor/Rep:** This manual must be given to the caregiver responsible for this chair and its occupant.

**Caregiver:** Before using this chair, read this manual thoroughly and save for future reference.

# Contents

FOREWORD.....	1
GENERAL INFORMATION.....	2
1 SAFETY REQUIREMENTS .....	3
1.1 Training.....	3
1.2 Application.....	3
1.3 Shipping and Storage .....	3
1.4 Pre-Service Check.....	3
1.5 Hazards .....	4
1.5.1 Location of Chair - “Danger of Tipping or Falling Objects”.....	4
1.5.2 Transport Wheels - “Danger of Tipping” .....	4
1.5.3 Re-Positioning of Optional Height Adjustable Armrests- “Danger of Clamping” .....	4
1.5.4 Unintended Movement - “Danger of Falling or Collision” .....	4
1.6 Improper Use.....	4
1.7 Cleaning .....	4
1.8 Maintenance .....	6
1.9 Child Specific Instructions .....	7
2 OPERATION AND MOVEMENT .....	8
2.1 Gliding Motion.....	8
2.2 Caregiver Lock.....	8
2.3 Height Adjustable Armrests - Optional.....	9
2.4 Transport Wheels .....	9
2.5 Accessories (Options) .....	9
3 INSPECTION AND FUNCTIONAL TESTING .....	10
3.1 Inspection .....	10
3.2 Functional Testing.....	10
4 TECHNICAL INFORMATION.....	11
4.1 Specifications .....	11
4.2 Broda Seating Aspire Pediatric Glider Parts Schematic Drawings .....	12
5 WARRANTY.....	18

## FOREWORD

Congratulations on your purchase of a Broda chair and thank you for your confidence in our company and products.

This manual will assist you in making the best use of the capabilities of your Broda chair and will ensure that you quickly become familiar with its operation.

After reading this manual, if you have any questions about the safe and effective operation of your Broda chair or accessories contact your local Broda representative or our Head Office Customer Service personnel for further assistance.

## GENERAL INFORMATION

This document provides guidance on the safe and effective operation of the Broda chair.

Information in this manual must be followed at all times.

Anyone involved with the operation or maintenance of the Broda chair, must read this operating manual before using the chair.

Anyone who is unfamiliar with, unwilling, or unable to adhere to the safety and operating instructions, is not permitted to operate or move the chair.

A copy of this instruction manual must always be available.

Broda accepts no liability for damages, injury or accidents caused by operating errors, improper maintenance, or disregard of the instructions in this manual.

Broda reserves the right to make changes to the specifications, dimensions, functions, or components of its products without notice. Product representations in this manual may vary from delivered products.

Each Broda chair has a unique identifying serial number that must be maintained on the chair as well as with any equipment record

# **1 SAFETY REQUIREMENTS**

## **1.1 Training**

**Before and after the chair is put into service, this manual must be read thoroughly by all individuals responsible for the child's care. (referred to in this manual as caregiver). This includes but not limited to: therapy staff, teaching staff and other education professionals, physician and/or other healthcare professional, parent and/or guardian and all other individuals who are involved in the care and safety of the child.**

The operations of the chair must be performed by the child's caregiver who is responsible for seating for the child. All The operations and adjustments performed should be done in a manner to ensure the overall safety, comfort and well-being of the child, individual responsible for their care and third party. All operations and adjustments required for the child should be determined by all caregivers responsible for seating.

## **1.2 Application**

The Aspire Pediatric Glider is intended for use by children who are under professional care, or a parent and/or guardian. The suitability of the Aspire Pediatric Glider must be determined by a qualified individual who is familiar with the seating needs of the child. Any other use of the chair is excluded from possible liability claims.

The chairs are not explosion resistant and must not be used where there are flammable gases or liquids present (e.g., anesthetics, volatile solvents and cleaners, etc.)

The Aspire Pediatric Glider is designed for use with specific Broda parts and accessories. The use of non-Broda parts or accessories with a Broda chair will void the warranty and is excluded from possible liability claims.

The Aspire Pediatric Glider may only be used as described in this manual and with proper regard for recognized education, healthcare and workplace safety and accident prevention practices.

## **1.3 Shipping and Storage**

The Aspire Pediatric Glider should be shipped and stored in an upright position and not stacked higher than 3 boxes. No other materials should be shipped or stored on top of a Broda box. Broda boxes should not be placed on pallets.

The Aspire Pediatric Glider should be shipped and stored at temperatures between -20°C and 40°C. It should not be used until it is between 0°C and 30°C.

The Aspire Pediatric Glider should be kept in a clean, dry environment. Do not leave the chair outdoors as it may cause the paint to peel.

Upon receipt, the shipping carton must be immediately examined for damage. Any damage should be noted on the delivery receipt and a request for inspection by the transportation company should be made. Next, the shipping carton should be opened and the chair must be examined for concealed shipping damage. If the chair appears to be damaged, do not use the chair. File a concealed damage report with the transportation company.

## **1.4 Pre-Service Check**

The Aspire Pediatric Glider is delivered fully assembled. If the chair does not appear to be ready to use upon receipt, immediately contact your supplier and do not put the chair into service until any concerns have been resolved.

Visually inspect the chair for damage, missing parts, and loose fasteners prior to testing the chair's functions. Functional testing must be successfully completed after visual inspection and before use. These obligations apply to the chair's first use and to all subsequent uses (Section 3: Inspection and Functional Testing).

## **1.5 Hazards**

### **1.5.1 Location of Chair - “Danger of Tipping or Falling Objects”**

Broda recommends that when a child has been moved to their destination, the chair is placed where the child cannot reach handrails or other objects, fixed or movable. This is to prevent the child from pulling the chair over or pulling themselves off the seating surface and to prevent the child from pulling movable objects onto the chair and themselves.

Broda recommends that the chair be used in a supervised area to prevent untrained individuals from unauthorized operation, movement, or unsafe actions in order to prevent risk of tipping or damage to the chair.

Broda recommends that a chair only be located on a level surface to minimize the risk of tipping over.

### **1.5.2 Transport Wheels - “Danger of Tipping”**

The transport wheels found on the rear of the Aspire Pediatric Glider are for ease of transporting an unoccupied chair. Do not transport the Aspire Pediatric Glider while it is occupied. Doing so could cause the chair to tip, causing serious injury to individuals.

### **1.5.3 Re-Positioning of Optional Height Adjustable Armrests- “Danger of Clamping”**

The Aspire Pediatric Glider offers optional height adjustable armrests. Before movement of the armrest height, ensure the child’s and caregivers’ body are clear of all pinch points.

### **1.5.4 Unintended Movement - “Danger of Falling or Collision”**

Broda recommends the Aspire Pediatric Glider for indoor use within an education institute, healthcare facility or home, and where there is not enough slope to cause the chair to move unaided. Chairs used where the surface is uneven or sloped are at risk of unintended movement and could become a serious danger to child, caregiver(s), or third party. We recommend that the Aspire Pediatric Glider is located away from stairwells, elevators, and exterior doorways.

## **1.6 Improper Use**

As outlined, the improper use of the chair is dangerous to the child, caregivers, or third parties, and can consist of, but is not limited to the following:

- 1) Unauthorized operation of the chair’s functions.
- 2) Unauthorized movement of the chair.
- 3) Inappropriate use of the chair by a child who has not been assessed by a qualified professional responsible for their seating.
- 4) Attempting to operate multiple chair functions simultaneously by one or more caregivers.
- 5) Attempting to move the chair while occupied by a child.
- 6) Leaving a child unattended
- 7) Leaving a child in a chair on a sloping surface.
- 8) Leaving a chair unattended on a sloping surface.
- 9) Using non-Broda accessories on the chair.
- 10) Using the chair at temperatures below 0°C.
- 11) Using the chair as a shower or bathing chair.
- 12) Using the chair for any use other than its intended purpose.

## **1.7 Cleaning**

The Aspire Pediatric Glider should be wiped clean with soap and water. Diluted household strength ammonia or chlorine based cleaner, as well as a hospital grade cleaner may be used if necessary.

Refer to the following guide for cleaning certain staining agents (Applies to the Permablok3® vinyl, as per the vinyl manufacturer’s recommendations) The frame and components of the chair can be cleaned using the same procedure as the vinyl.

The steps below are also located in the Cleaning Guide found on the back of the Broda chair.

## Staining Agent

## Cleaning Procedure

Eye Shadow / Mascara

Step 1

Grease / Suntan Lotion / Chocolate

Step 1

Blood / Bodily Fluids

Step 2

Red Lipstick

Step 2

Oil Base Paint / Tar / Asphalt

Step 3

Other Tough Stains

Step 4 or 5\*

**Step 1:** Remove excess spill with a damp cloth. Clean with a 1:1 mix of Ivory® liquid and water. Rinse with clean water and dry.

**Step 2:** Use a straight application of concentrated cleaners such as Formula 409® or Fantastik® Spray Cleaner. Then wipe with a clean cloth. If using a hospital grade cleaner, follow the diluting instructions on the label.

**Step 3:** Use a 1:1 mix of ammonia and water or a 1:4 mix of bleach and water. Rinse with clean water and dry.

**Step 4:** Use a straight application of naphtha (lighter fluid). Rinse thoroughly with clean water and pat surface dry.

**Step 5:** Use a 1:1 mix of isopropyl alcohol and water. If the stain persists, use straight alcohol. Rinse thoroughly with clean water and pat dry. If the stain remains, use a 1:1 mix of acetone and water. Rinse with clean water and pat surface dry.

**\*Note:** for cleaning that requires steps 4 or 5 – Use a soft cotton cloth saturated with the cleaning material and rub the stain in circles 10 times. Pat dry with another soft cotton cloth, and check results.

Thoroughly clean all removable parts and padding, as well as the frame and components.

Broda chairs should not be cleaned with petroleum-based cleaners. Any petroleum based products that come in contact with any vinyl surface should be removed as quickly as possible. Petroleum based products make vinyl brittle and will damage the seating surface and cushions. Metal parts and cushions should be wiped completely dry after cleaning. Do not launder vinyl padding.

Do not allow the chair to air dry. Leaving the chair to air dry and not ensuring the entire chair is completely dry may cause the frame and components to rust. Solvents such as those found in spray lubricants should not be used on Broda chairs as they can damage moving parts.

Frequency and method of cleaning the chairs should be determined by facility infection control protocols. If visibly soiled, thoroughly clean the chair immediately as per the cleaning instructions in this manual.

The cleaning instructions in this manual are guidelines only. Results may vary under actual conditions. The information does not relieve the user of proper and safe use of the product and all cleaning agents and consideration for the overall cleaning maintenance of the chair. Cleaning and care instructions must be followed in conjunction with facility infection control protocols.

Broda will not accept warranty or liability claims on chairs that have not been cleaned according to the instructions or cared for in proper regard for the child, caregiver and third-party safety and hygiene. The use of certain agents may be harmful to the surface appearance and lifespan of the vinyl. Broda assumes no responsibility resulting from the use of such cleaning agents to the vinyl.

Touch up paint is available for the powder coated frame. Please call Broda's Customer Service Department if touch up paint is required. Do not leave Broda chairs outdoors as the frame is not UV protected. Leaving the chairs outdoors could cause the paint to peel.

Formula 409® is a trademark of the Clorox Company.

Fantastik™® is a trademark of DowBrands, Inc.

Trademark of the Dow Chemical Company

Ivory® is a trademark of Proctor and Gamble

## **1.8 Maintenance**

The maintenance on the Aspire Pediatric Glider will vary with the amount of use and the condition of the children using the chair.

In regular use, after the initial inspection and functional testing, the chair should be inspected and tested bimonthly. We recommend visually inspecting for signs of wear, damage, loose or missing fasteners, and other safety concerns. Periodic testing of chair functions is also necessary. If a breakage, defect, or operational problem is detected, the chair must be successfully repaired, inspected and tested for function before it is returned to service.

The chair should be inspected and tested as often as each use if the chair is used by:

- 1) Aggressive or agitated children.
- 2) A facility with irregular or sloped surfaces.
- 3) Any unauthorized person.

Do not use lubricants that contain solvents. If necessary, white food grade grease or lubricant can be used on any sliding components.



## **1.9 Child Specific Instructions**

The primary caregiver responsible for the specific child's seating shall add additional instructions necessary for the safe and effective use of the chair based on their professional experience and knowledge of the child's specific conditions and requirements.

Broda representatives are not professional caregivers and will not know the specific requirements of the individual using the chair. Broda relies on the knowledge, experience, and judgment of the child's professional caregiver to ensure the specific child's safety and comfort needs are satisfied while using the chair.

These instructions form an essential part of the safety requirements for using the chair and must be made available to all caregivers. Space is provided below to include these instructions.

---

---

---

---

---

---

---

---

---

---

---

---

---

---

---

---

---

---

---

---

---

---

---

---

## 2 OPERATION AND MOVEMENT

Safety measures as described in Section 1 must be observed when operating the chair's functions or moving the chair. Only authorized caregivers should attempt to operate or move a chair. The caregiver must use proper body mechanics when operating the chair.

### 2.1 Gliding Motion

The Aspire Pediatric Glider has a gliding motion that aids in providing a calming effect as well as stimulation and enjoyment. The gliding can be activated or locked with the caregiver lock.



### 2.2 Caregiver Lock

The caregiver lock prevents any unwanted gliding. The lock is located at the rear of the chair under the fabric apron.

**WARNING: Only apply the caregiver lock when the chair is unoccupied.**

To Lock and Unlock the caregiver lock:

- Lift up or reach under the flap to access the caregiver lock.
- Pull the handle.
- Turn approximately a quarter turn and insert the tab into the slot for locking, or release the tab for unlocking.
- Secure the flap back in place.

**WARNING: Do not place fingers near tab as this could cause pinching.**



### 2.3 Height Adjustable Armrests - Optional

The Aspire Pediatric Glider offers standard fixed height armrests. Optional height adjustable armrests can easily be adjusted in order to accommodate various individuals. The armrest height should be adjusted to provide correct arm support for the child as determined by the caregiver.

To Adjust the Armrest Height:

-Squeeze the pins together which are located under the armrest flap.

**WARNING: DO NOT place fingers at the top of the pins as this could cause pinching. Place fingers in the concave shape of the pins.**

-Raise or lower the arm to the desired height.

**WARNING: DO NOT place fingers anywhere underneath the arm while adjusting, as this could cause pinching.** Upon releasing the pins the armrest height will lock into place.

Secure the outside flap on the side panel. Change the height on the other arm as desired.

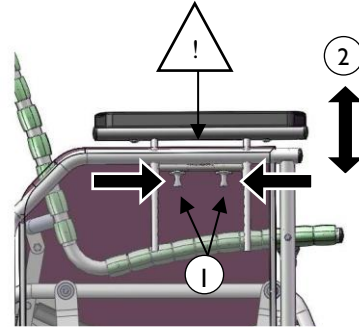

### 2.4 Transport Wheels

The Aspire Pediatric Glider has two rear transport wheels for ease of transporting the chair while unoccupied.

To Transport the Chair:

-Apply the caregiver lock.

-Standing directly behind the chair, tilt the chair back onto the transport wheels and transport to the desired location.

-Once the chair is in the desired location and in the upright position, the caregiver lock may be released if desired.

**WARNING: Do not transport the chair while it is occupied.**



### 2.5 Accessories (Options)

It is recommended that only Broda accessories are used on the Aspire Pediatric Glider. The correct installation of the Broda accessory is very important. We recommend that the chair is ordered with the required accessories already installed. Only authorized caregivers who thoroughly understand the accessory installation procedures should attempt to install their Broda accessories without assistance from their local Broda representative. Broda does not recommend use of other manufacturer's accessories on our chairs.

# **INSPECTION AND FUNCTIONAL TESTING**

Safety measures as described in Section 1 must be observed when inspecting or testing a chair. Only authorized caregivers or maintenance staff should attempt to inspect or test a chair.

## **2.6 Inspection**

Visual inspection is recommended for signs of wear, damage, loose or missing fittings, and other safety concerns. If a breakage, defect, or operational problem is detected, the chair must be repaired, inspected and tested for function before it is returned to service.

We recommend that the chair be inspected as often as each use if there is any reason to be concerned about the possibility of increased wear or loose or missing fittings. **At a minimum, in regular use the chair should be inspected on a bimonthly basis.** The visual inspection procedure should include at least the observation of all the fittings (fasteners):

The visual inspection procedure should include at least the observation of the following parts:

- 1) The vinyl straps used in the seat and back
- 2) The cushions
- 3) The caregiver lock and pin that engages the locking plate
- 4) The armrest height adjustment pins (applies on certain models)

The visual inspection procedure should include the observation of any installed accessories. The visual inspection should be performed by the facility, or if in a private residence, by the individual responsible for the chair.

## **2.7 Functional Testing**

**It is recommended that the chair be tested for operation of the chair's functions while it is unoccupied.** The testing may be as often as each use if there is any reason to be concerned about the possibility of increased wear or damage to the chair's components. At a minimum, in regular use the chair should be tested for functions as described in Section 3.

If the caregiver or maintenance department performing the functional testing believes that any function is not operating correctly, the chair should be taken out of service until a satisfactory functional test can be completed.

### **3 TECHNICAL INFORMATION**

#### **3.1 Specifications**

##### Specifications for Aspire Pediatric Glider Models 100-PS, 100-PM, 100-PL

1. Gliding: Smooth, gliding action with a locking feature.
2. Caregiver Lock Caregiver lock can be activated to prevent unwanted gliding.
3. Frame: 16 gauge powder coated tubular steel
4. Seat/Back Surface: BRODA Comfort Tension Seating® Strapping is 1.5” wide, by .130” thick; contains fungicide, has shape memory retention, is fire retardant
5. Arms: Fixed armrest height
6. Padding: Standard removable padding – Seat Pad, Back Pad, Side Panels  
The 34 ounce healthcare vinyl fabric covering is manufactured to meet the following requirements: DIN 75 200/DIN 53 438; MVSS 302, M2; CAL 117, and Wyzenbeck Heavy Duty Abrasion Test; has an antimicrobial, antibacterial, anti-stain and anti-static finish; Cold crack of -20°C. Polyurethane foam meets CAL 117-2013.  
  
Removable seat and back pads are covered with an 8 ounce soft vinyl which meets CAN2-162 flammability standard for hospital textiles. Polyurethane foam meets CAL 117-2013.
7. Transport Wheels Rear wheels for transporting of chair (while unoccupied)
8. Seat Depth: 10” 100-PS, 12” 100-PM, 14” 100-PL
9. Seat Height: 10” 100-PS, 12” 100-PM, 14” 100-PL
10. Seat Width: 12” 100-PS, 14” 100-PM, 16” 100-PL
11. Weight Capacity: 200 lbs

All dimensions are  $\pm 0.5$ ”.

### 3.2 BRODA Seating Aspire Pediatric Glider Parts Schematic Drawings

ITEM	PART NUMBER	DESCRIPTION	QTY
1	X20100	PED GLIDER BASE ASSEMBLY	1
2	SEE TABLE	PED GLIDER FXED/ADJST ARM ASSEMBLY	1
3	X20103	PED GLIDER HANGER FRONT ASM	1
4	X20104	PED GLIDER HANGER REAR ASM	1
5	411133000	SCREW 1/4-20 X 2 HEX CAP, ZINC	4
6	411131000	SCREW 1/4-20 X 1-1/2 HEX CAP, ZINC	4
7	410132001	NUT 1/4-20 NYLON INSERT LOCKNUT, ZINC	8

PED GLIDER FIXED/ADJST ARM ASSEMBLY	
SIZE	PART #
FIXED	X20103
ADJUSTABLE	X20104

DO NOT SCALE DRAWING UNLESS OTHERWISE SPECIFIED. DIMENSIONS ARE IN INCHES.	REV	DATE	NAME	CHANGED DESCRIPTION
TOLERANCES: FRACTIONAL ±.005" ANGULAR: MAX CH ±0.5° TWO PLACED DECIMAL ±0.0010" THREE PLACED DECIMAL ±0.0005"				
FINISH: MINIMUM .07 STITCHES PER INCH MINIMUM .15" ALL SEAMS/SEAMS				
PROPRIETARY AND CONFIDENTIAL				
THE INFORMATION CONTAINED IN THIS DRAWING IS THE SOLE PROPERTY OF BRODA. REPRODUCTION, REUSE, OR DISSEMINATION OF THIS INFORMATION WITHOUT THE WRITTEN PERMISSION OF BRODA ENTERPRISES IS PROHIBITED.				
MODEL NAME: PEDI GLIDER	1000	0	TRC	FIRST RELEASE
DATE: 06/03/2017				

REV	DATE	NAME	CHANGED DESCRIPTION
0	06/03/2017	TRC	FIRST RELEASE

SIZE	DWG. NO.	REV
A	PED GLIDER	0

TITLE: PED GLIDER ASSEMBLY

SCALE: 1:10 WEIGHT: SHEET 1 OF 1

ITEM	PART NUMBER	DESCRIPTION	QTY
1	SEE TABLE	FRM BASE XX" PED GLIDER	1
2	4-30101 200	WHE WHEEL 1-1/2" BLACK	2
3	4-30101 100	WHE AXLE KIT, 1-1/2" / 3" WHEE	2
4	410003081	PLUG RND VINYL GLIDER FEET, BLACK	4

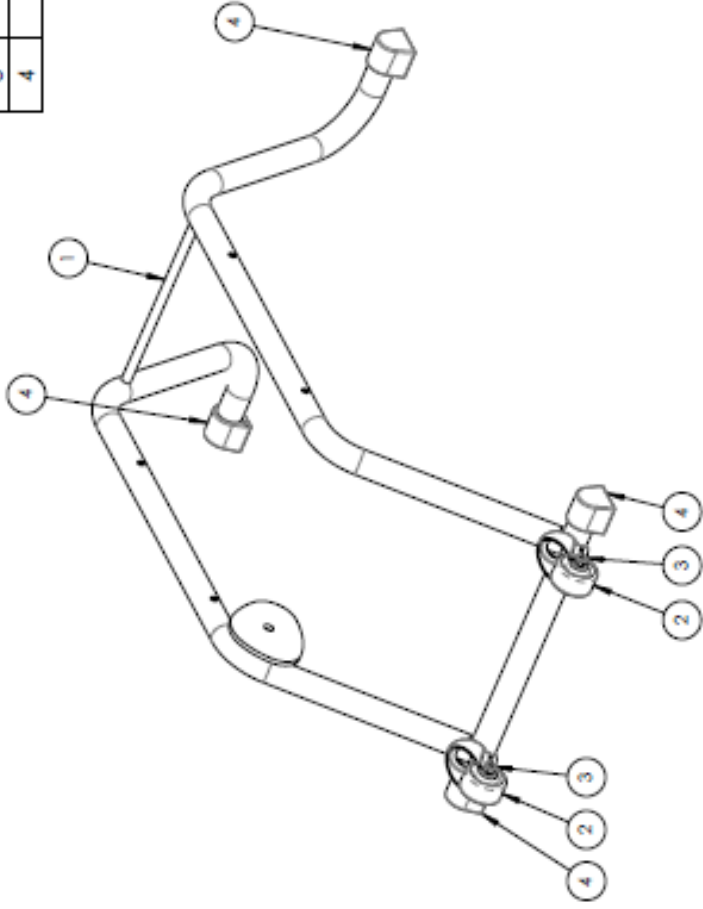

FRM BASE XX" PED GLIDER	
SIZE	PART #
17"	208102100
14"	208102100
16"	202102100

		5018 Normans Centre Dr. Richfield, Ohio 44137 Phone: 1-800-688-0037	
DO NOT SCALE DRAWINGS UNLESS OTHERWISE SPECIFIED. DIMENSIONS ARE IN INCHES TOLERANCES: FRACTIONAL ±.007" ANGULAR: MAX CH ±0.5° ANGULAR: BEND ±1° TWO PLACED DECIMAL ±0.010" THREE PLACED DECIMAL ±0.005" FINISH: MINIMUM OF 3 FINISH PER INCH SEE BOM FOR ALL SPECIAL FINISHES FINISH		ECH REV NAME DATE	CHANGED DESCRIPTION DATE
TITLE: PED GLIDER BASE ASSEMBLY		SIZE DWG. NO. REV <b>A</b> X20100 <b>0</b>	
PROPRIETARY AND CONFIDENTIAL THE INFORMATION CONTAINED IN THIS DRAWING IS THE SOLE PROPERTY OF BRODA, THE BYPASSES, AND PERMITTED CONTRACTORS. A WHOLE WITHOUT THE WRITTEN PERMISSION OF BRODA ENTERPRISES IS PROHIBITED.		1000 0 BEST RELEASE	TPC 00/03/2017
MODEL NAME: MODEL LOCAL TECH	5	4	3
SCALE: 1:6 WEIGHT:		SHEET 1 OF 1	

ITEM	PART NUMBER	DESCRIPTION	12" QTY	14" QTY	16" QTY
1	SEE TABLE	FRM FIX ARM/SEAT XX"PED GLIDER	1	1	1
2	430402000	ARM A-3 ARMREST SEE TABLE	2	2	2
3	SEE COLOR	SEE TABLE	14	16	18
4	410005000	FASTENER ALUMINUM 3/16" RIVET	28	32	36
5	412133001	SCREW 1/4-20 X 1-1/4 PAN GUAD, ZINC	4	4	4
6	410003030	PLUG RND 1" 14-23GD INSIDE RIBBED, BLACK	4	4	4

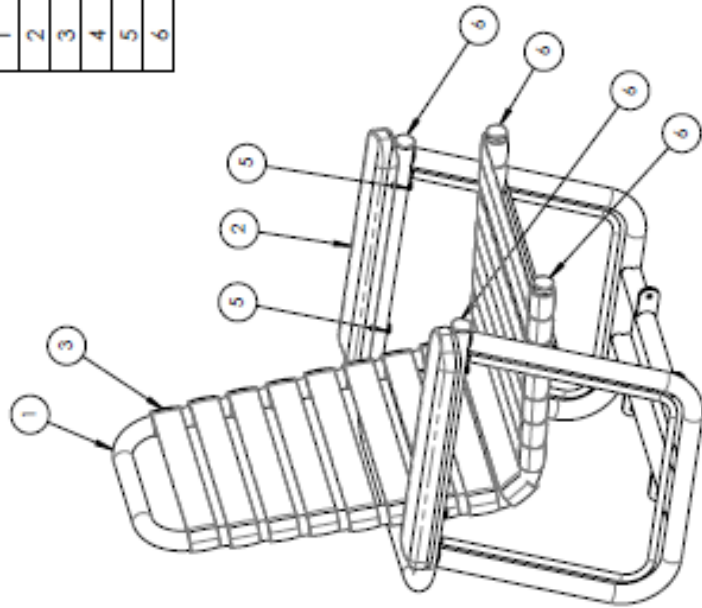

FRM FIX ARM/SEAT XX"PED GLIDER	SIZE	PART #
12"	205500-100	430130100
14"	205500-100	430130200
16"	205500-100	430130300

BULK STRAP	COLOR	PART #
12"	CHERRY	430130100
14"	CHERRY	430130200
16"	CHERRY	430130300
12"	BROWN	430130400
14"	BROWN	430130500
16"	BROWN	430130600

STRAP LENGTHS XX" PED GLIDER	LOCATION	12"	14"	16"
SEAT	19"	20"	21"	
SEAT	22"	23"	24"	
SEAT	22"	23"	24"	
SEAT	19"	20"	21"	
SEAT	16.5"	17.5"	18.5"	
SEAT	17.5"	18.5"	19.5"	
SEAT	17"	18"	19"	
SEAT	17.5"	18.5"	19.5"	
SEAT	16.5"	17.5"	18.5"	
SEAT	17"	18"	19"	
SEAT	16.5"	17.5"	18.5"	
SEAT	17"	18"	19"	
SEAT	16.5"	17.5"	18.5"	

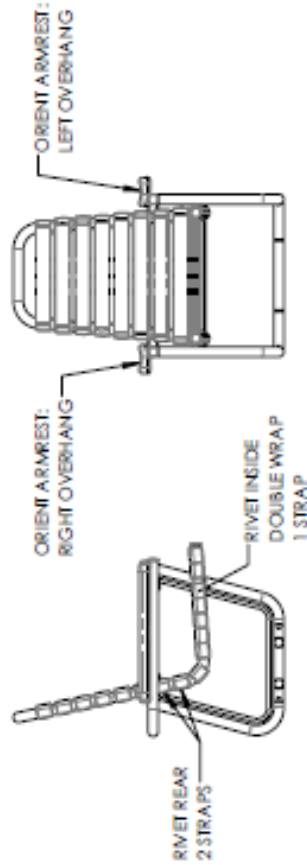

DO NOT SCALE DRAWING  
UNLESS OTHERWISE SPECIFIED  
DIMENSIONS ARE IN INCHES  
TOLERANCES:  
FRACTIONS ± .007"  
DECIMALS: MAX OF .003"  
ANGLE: BEND ± 1°  
TWO PLACED DECIMAL ± 0.010"  
THREE PLACED DECIMAL ± 0.005"  
FINISH:  
MINIMUM .07 STITCHES PER INCH  
MAXIMUM .15" ALL SEAMS & SEWS  
MATERIAL:  
FIBER

PROPRIETARY AND CONFIDENTIAL  
THIS INFORMATION CONTAINED IN THIS DRAWING IS THE SOLE PROPERTY OF BRODA. ANY REPRODUCTION IN PART OR AS A WHOLE WITHOUT THE WRITTEN PERMISSION OF BRODA ENTERPRISES IS PROHIBITED.  
MODEL NUMBER: 430130100  
DATE: 08/02/2017

ECN	REV	CHANGED DESCRIPTION	NAME	DATE
1000	0	FIRST RELEASE	TNC	08/02/2017

SCALE: 1:8 WEIGHT: SHEET 1 OF 1

**BRODA**  
Sollingmans Centre Dr.  
Pittsboro, North Carolina  
Phone: 1-800-668-0037

TITLE:  
PED GLIDER FIXED ARM ASSEMBLY

SIZE DWG. NO. REV  
**A** X20101 **0**







ITEM	PART NUMBER	DESCRIPTION	QTY
1	SEE TABLE	FRM REAR HANGER XX" PED GLIDER	1
2	430141000	BEARING FOR GLIDER	4
3	430008300	INDEXING PLUNGER (GLIDER)	1

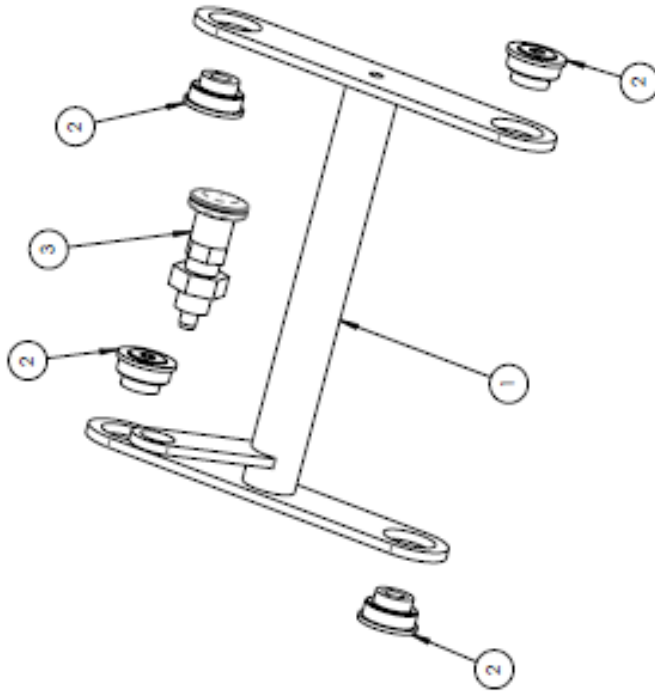

FRM REAR HANGER XX" PED GLIDER	
SIZE	PART #
12"	200002101
14"	200002101
16"	200002101

DO NOT SCALE DRAWING UNLESS OTHERWISE SPECIFIED. DIMENSIONS ARE IN INCHES TOLERANCES: FRACTIONS ±.007 DECIMALS: MAX CH ±.015" ANGULAR: BEND ±1° TWO PLACES DECIMAL ±.0010" THREE PLACES DECIMAL ±.0005" SEWING: MINIMUM 1/2" STITCHES PER INCH MEMBERS USE ALL SEWING DEVICES WAXED FINISH		ECN	REV	CHANGED DESCRIPTION	NAME	DATE	 540 Birmingham Centre Dr Fitchville, Ontario M3B 3J9 Phone: 1-800-668-0437		
							TITLE:		
							PED GLIDER HANGER REAR ASM		
							SIZE DWG. NO.	REV	
							A X20104	0	
							SCALE: 1:3	WEIGHT:	
							30/03/2017	SHEET 1 OF 1	
PROPRIETARY AND CONFIDENTIAL THE INFORMATION CONTAINED IN THIS DRAWING IS THE SOLE PROPERTY OF BRODA. IT IS EMPLOYED UNDER LICENSE OR AS A TRADE SECRET. WITHOUT THE WRITTEN PERMISSION OF BRODA, REPRODUCTION OR DISSEMINATION IS PROHIBITED.		1000	0	FIRST RELEASE	TPC	30/03/2017	SCALE: 1:3	WEIGHT:	
MODEL NAME		MODEL LOCATION		DATE		DRAWN BY		CHECKED BY	

# 5 WARRANTY

## MANUFACTURER WARRANTY

**Effective 10/15/2018**

From date of purchase Broda warrants the side frames and cross members located on the base frame, for the Expected Lifetime\* of the original purchaser/ user, when purchased from an Authorized Broda Dealer. \*Expected Lifetime of the frame is 10 years.

In addition, Broda warrants its other product components, except the seat cushion and covers (which are not warranted), to be free from defects in materials and workmanship for a period of 2 years from the date of purchase, as indicated on the original purchase order. This warranty is non-transferable.

**The warranty is subject to the following conditions:**

A serial number or invoice number is required for warranty coverage. The warranty shall not apply to serial numbered items if the serial number has been removed or altered in any way.

Warranty is valid for "new" purchases only. All other items will be warranted at the sole discretion of Broda.

If within such warranty period any such product shall be proven to be defective through examination, inspection and testing as deemed necessary, such product shall be repaired or replaced at Broda's discretion. This warranty does not include on-site labor.

On request, defective parts must be returned to the factory, pre-paid and insured, within 30 days. Failure to do so, will result in the owner incurring the cost of the replacement parts. Photos of defective parts may be requested as an alternate to returning product.

**Limitations and Exclusions:**

This warranty does not cover damages that arise from improper handling, cleaning, maintenance, storage or negligent use. The warranty does not cover Broda's wheelchairs and chairs used in any way, other than the manner in which it was designed and recommended.

Modifications, incorrect assembly or installation to Broda products or the use of non-Broda products voids the warranty. Installation of parts that require the frame to be altered in any way, must be completed by a Broda Representative, unauthorized performances will void the warranty.

This warranty does not cover freight damage (see Damaged Freight Policy).

Broda retains the right to make product design and product application changes without notice.

The application of Broda products shall remain the responsibility of the purchaser or user. Please reference the model specific operating instruction manuals for safety requirements, inspectional and functional testing, technical information and more.

Warranty does not include on-site labor for the installation of warranty parts or warranty repairs. The owner may return to Broda products for warranty replacement or repair by shipping items prepaid and insured to the factory. Warranty completed at the factory includes both materials and labor. The decision to repair or replace parts is at the discretion of Broda. All returns to the factory require prior authorization from Broda.

**WC-19 Transportation Certified Products:**

Vehicle Transport Products and Options are available by factory install only. It can NOT be retrofit to existing models or serviced in the field. All components of the vehicle transport packages are subject to specific maintenance requirements, to maintain the Broda warranty.

Due to the testing requirements of the vehicle transport chair, Broda warranty limitations apply to non-factory installed repairs. Warranty and maintenance repairs must be made by Broda authorized service technicians. Any replacements or repairs made by unauthorized person (s) will void this warranty and Broda assumes no liability on the performance of said components.

DO NOT modify the transport chair. Modifications may change the transport chair's structure and center of balance, which may increase the risk of serious injury to the user and void the warranty. If a problem is detected with any of the Vehicle Transport Product and Option components or any components of the chair, remove the wheelchair or chair from service and contact Broda immediately. Chairs involved in vehicle accidents should be taken out of use immediately.