

APPROACH SYSTEM INSTALLATION INSTRUCTIONS

Parts Included:

- 1 **Approach** motorized counter lift
- 1 Safety bar and control button
- 2 Counter support brackets
- 1 Large mounting bracket
- 2 Small mounting brackets

Hardware bag with:

- 8 1/4" x 2" hex head lag screws
- 8 1/4" - 20 x 1" button head cap screws
- 12 1/4" spring washers
- 4 1/4" - 20 lock nuts
- 4 5/16" - 18 x 1" button head cap screws
- 4 5/16" spring washers

Other Items Needed:

- Arc Fault Interrupt Circuit Breaker (AFCI Required)
- Ground Fault Circuit Interrupt Power Supply (Required)
- Level
- Tape Measure
- 7/16" Socket Wrench
- 5/32" and 3/16" Hex Key Wrench
- Jigsaw
- Phillips Head Screwdriver
- #8 fasteners suitable for your counter material

Pre-assembly Considerations

1- The **ADAS Approach** system is designed for installation in both new construction and renovation situations. The system is designed to move counters, sinks and cooktops through 8" of vertical travel. It accommodates counters from 36" to 48" wide, and can hold sinks and cooktops with install cutouts up to 31" wide. The standard unit fitted with a counter 1-1/2" thick has a minimum height of 28" and a maximum height of 36" from the finished floor. Counters must have a backsplash.

2- We recommend a three-sided valance underneath the adjustable portion of the counter. This valance or fascia is necessary to attach the UP/DOWN control button and conceal the underside of a sink basin or cooktop. Construct the sides of the valance and adjacent cabinets flush with their countertops, and extend the sides far enough below the countertop to avoid creating a gap between the fixed counters and the adjustable counter. Refer to the Valance Construction section for suggestions on valance design.

3- The **Approach** system requires mounting to at least three wall studs. In some instances, it may be necessary to install 2" x 6" horizontal backer and 2" x 4" vertical backer between studs. Locate horizontal backer 20" high from finished floor, and locate vertical backer 16" on center from centerline (see figure 2). The counter must be positioned to allow at least 1/8" clearance throughout the range of height adjustment on each side of the moving counter section including the wall. See Pre-install Figure 1.

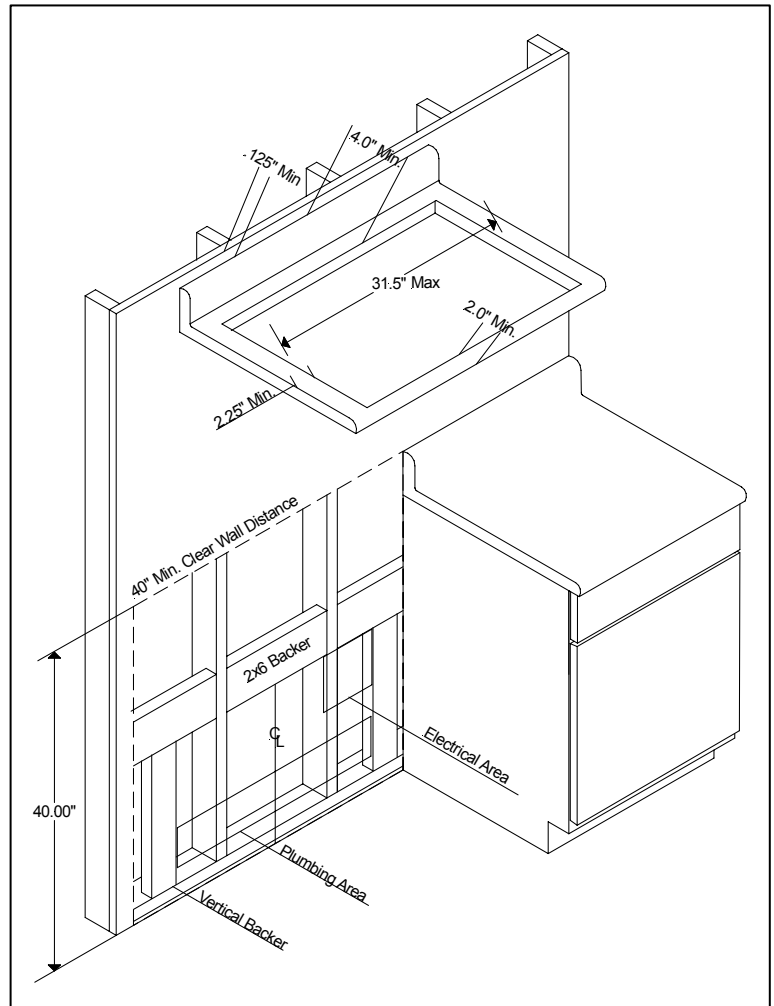

Pre-install Figure 1

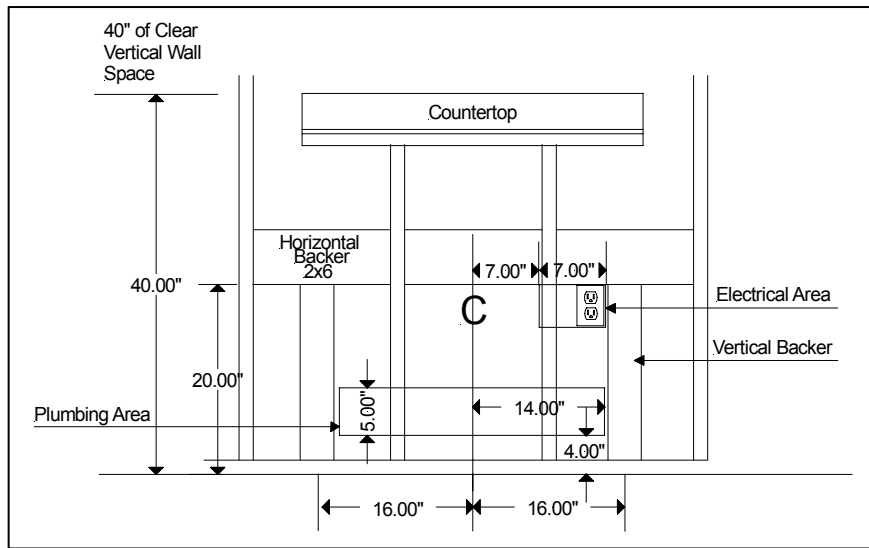

Pre-install Figure 2

4- The **Approach** system **MUST** plug into an Arc Fault Interrupt protected circuit using an AFI circuit breaker. The power outlet used must be a GFCI protected 110V outlet, located lower than 20" from the finished floor and from 7" to 14" to the right of centerline. See Pre-install Figure 2 for the electrical location. Contact a qualified electrician to install an AFI Circuit Breaker and a GFCI Power Outlet.

5- The **Approach for the Sink or Cooktop** accommodates sink or cooktop cutouts up to 31" wide. If using a sink, we recommend a shallow basin sink (5 1/2" - 6" in depth) with drains located in the rear of the basin in order to provide maximum knee clearance space for seated users. The Approach Drain Kit (sold separately) includes a flexible drain line, and requires a minimum 10" vertical distance between the trap connection and drain branch outlet. The location of the trap may be changed or modified to suit requirements of each installation, with installation done in compliance with building code. Supply lines are not provided, but should be flexible to accommodate vertical travel. Drain and supply lines must exit the wall no higher than 9" from the finished floor and no more than 14" from center line. See figure 2 for plumbing location.

Installation Instructions

Step 1 Uncrate the package, remove the safety bar and the motorized counter lift. Remove the large mounting bracket from the motorized lift.

Step 2 Attach the large mounting bracket to the wall with the top edge 22-1/2" from the finished floor, level, and on center. The 2" leg of the bracket lays flat against the wall with the 1-1/2" leg on top, forming the shelf to rest the system on. Use four 1/4" x 2" lag bolts and four 1/4" spring washers to securely mount the bracket to the horizontal backer and/or studs.

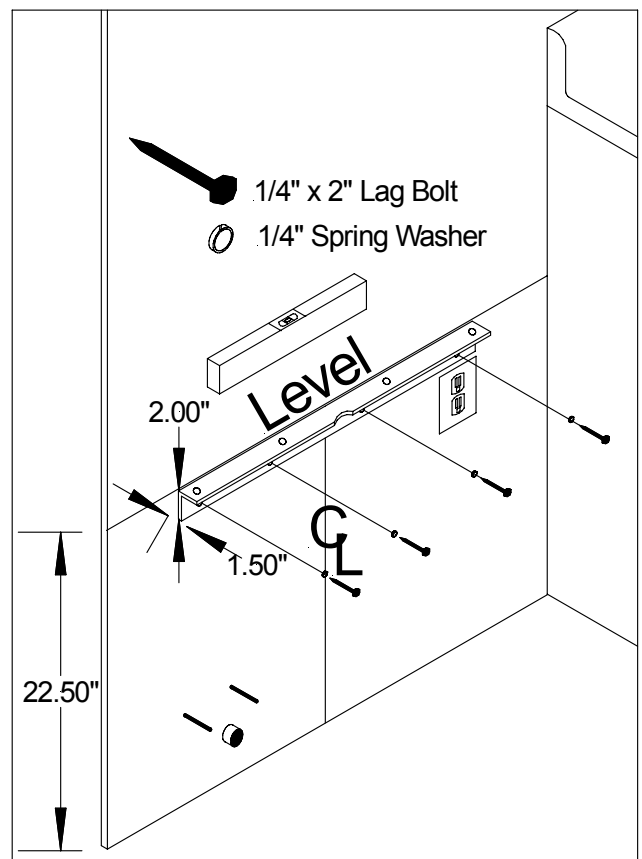

Step 2

Step 3 Set the motorized system on the large mounting bracket and secure using four 1/4" - 20 screws and four 1/4" - 20 lock nuts. Next, use four 1/4" x 2" lag bolts and four 1/4" spring washers to securely attach the two small mounting brackets to the vertical backer and/or studs. The system must realign to compensate for curves in the wall that may be present. Do this by loosening the four 1/4" - 20 screws attaching the small mounting brackets to the system, push the small mounting brackets flat against the wall, and retighten the four 1/4" - 20 screws to the system.

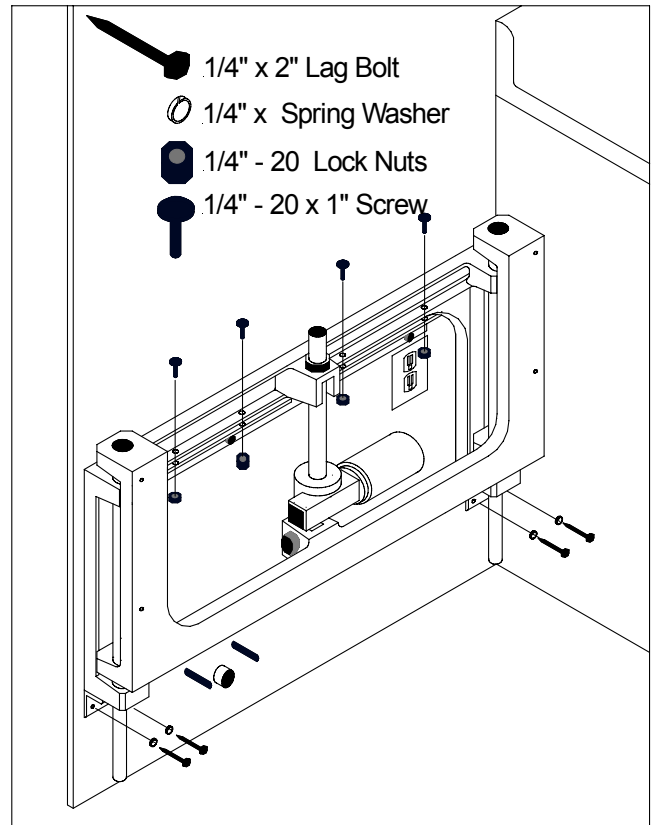

Step 3

Step 4 Attach the two counter support arms to the front of the system using four 5/16" - 18 screws and 5/16" spring washers.

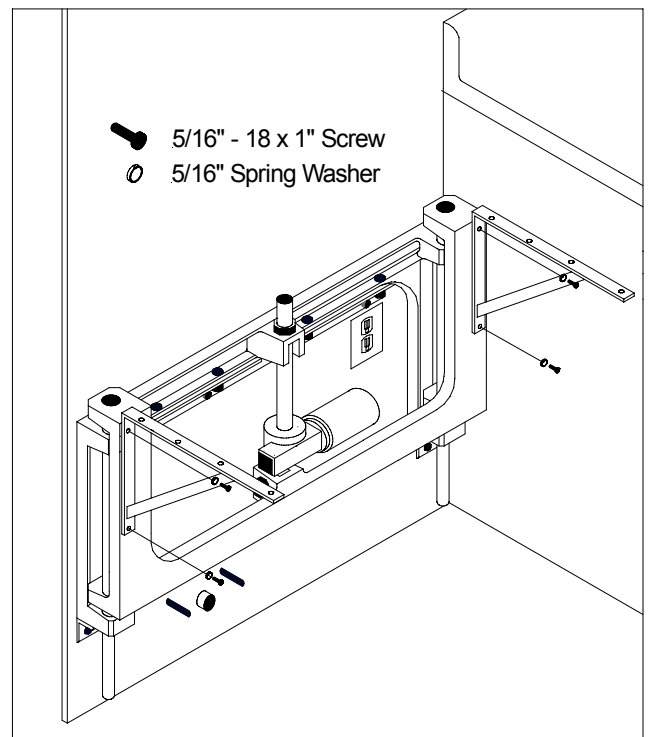

Step 4

Step 5 Position the moveable counter section with valance over the counter support brackets (refer to “Suggested Valance Design” section for ideas on how to construct a valance). Allow at least 1/8” clearance throughout the range of height adjustment on each side of the moving counter section including the wall. When the counter is positioned properly, attach the counter to the support brackets using fasteners suitable for your counter material (not provided). **DO NOT CREATE A PINCH HAZARD BETWEEN MOVING AND NON-MOVING COMPONENTS.** Water must not seep inside the valance where the electrical devices are. Caulk where necessary, especially between the valance and the counter top.

Step 6 The front of the valance or fascia must have a cutout for the Up/Down Button. The cutout must be positioned at least 2” in from the right corner, and must be 3/4” wide by 1-1/4” high. The Up/Down Button box requires 2” minimum clear space behind the cutout hole. Use a jigsaw and file and the Up/Down Button Cutout Template provided to cut the access hole in the valance.

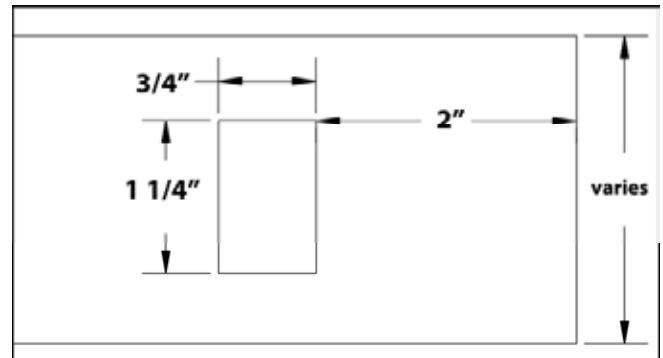

Step 6

Step 7 ALWAYS UNPLUG THE SYSTEM FROM THE GFCI PROTECTED WALL OUTLET WHEN INSTALLING OR ADJUSTING THE UP/DOWN BUTTON OR SAFETY BAR. Install the pushbutton 2” in from the right side of the fascia or valance mounted to the moveable counter section. With the system unplugged from the wall, slide the Up/Down Button into the cutout hole from the front. Connect the three wires with connectors to the corresponding wires and color match each connection. Note the green wire location should be on the bottom.

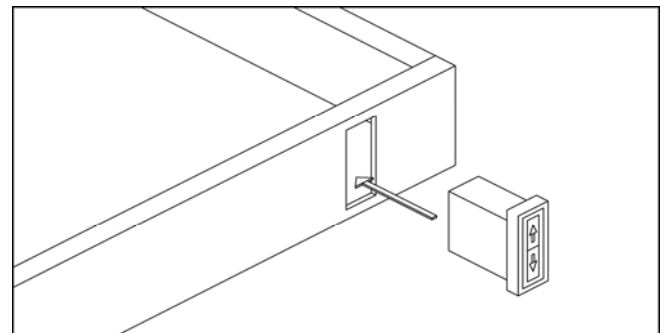

Step 7

Step 8 Attach the safety bar assembly inside the front face of the valance. Make sure the safety bar protrudes sufficiently below the valance to shut off when it meets an object in the downward travel.

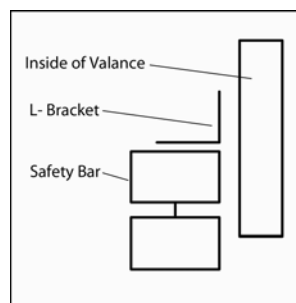

Step 8 Side View

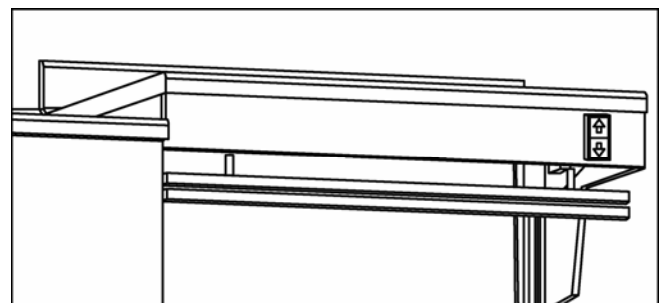

Step 8

Step 9 ATTENTION: You must use BOTH an Arc Fault Interrupt circuit breaker and a Ground Fault Interrupt power outlet with your ADAS Approach system. Failure to use an AFCI circuit breaker and GFCI protected 110V outlet may result in injury. If a 110V GFCI outlet on an AFCI protected circuit is not present, or if you are unsure of the type of outlet and circuit present, contact a qualified electrician to have both installed.

Plug the motor into the AFCI circuit GFCI protected 110V outlet. Raise and lower the unit to check for proper clearance. If the unit does not move when the DOWN button is pressed, adjust the screws in the safety bar.

Step 10 (Sink Model Only) The **Approach Drain Kit** is required for proper installation of a sink. Install the sink according to manufacturer instructions. Route PVC drain plumbing to the rear of the sink for improved knee clearance. Attach the flexible drain line (supplied with the **Approach Drain Kit**) using plumber's dope for Flexible PVC Pipes to PVC Pipes (ASTM D2564). Mark the length of flexible drain line needed; making sure the drain line is long enough to reach from the P-trap to the upper drain branch when the unit is in its highest position. Also, make sure the flexible drain line does not form a second P-trap when the unit is in its lowest position. Cut the drain line to length, and attach it to the P-trap with plumber's dope for Flexible PVC Pipes to PVC Pipes (ASTM D2564). Attach the spiral clamps (supplied with the **Approach Drain Kit**) to the flexible drain line where it connects to the PVC drain branch and the PVC P-trap. Use hose straps and secure the flexible drain line to reduce pressure on the rigid PVC plumbing.

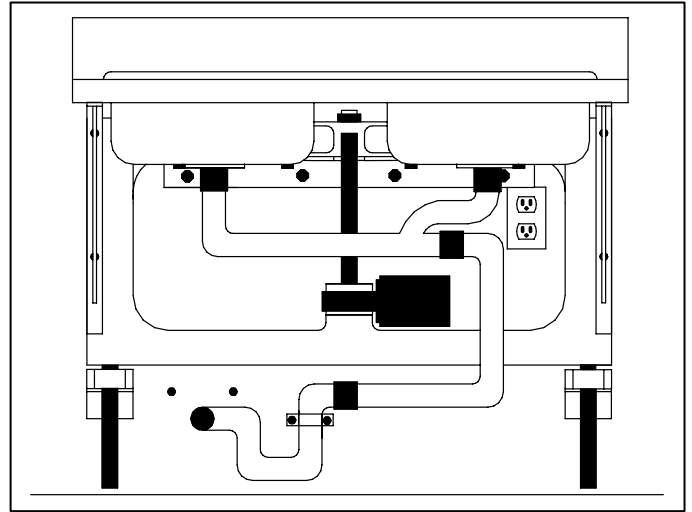

Step 10

Operating Notes

Always unplug the system from the AFCI circuit GFCI protected wall outlet when installing or adjusting the UP/DOWN button or Safety Bar. When installed and adjusted correctly, the Safety Bar engages after minimal contact with a foreign object. Adjust the Safety Bar sensitivity by tightening or loosening the bolts on the safety bar. Downward travel of the counter system is prevented when the Safety Bar is engaged, but the system will continue to have power in the up direction. The motorized counter lift has multiple power cutoff systems for safety. If it loses partial or complete power, check the following:

Power UP, no power DOWN	Safety Bar is engaged or disconnected.	Disengage Safety Bar, adjust sensitivity if necessary.
No power UP, no power DOWN	Thermal override in motor engaged.	Wait 30 minutes with no power to system, allow the motor to cool. Thermal override will reset itself.
No power UP, no power DOWN	Safety Circuit Breaker in AD•AS control box tripped.	Reset circuit breaker inside control box.
No power UP, no power DOWN	Ground Fault Circuit Interrupt outlet tripped.	Contact qualified electrical service person to reset GFCI outlet.
No power UP, no power DOWN	Arc Fault Interrupt circuit breaker tripped.	Contact qualified electrical service person to reset AFCI circuit breaker.