

TECHNICAL SPECIFICATIONS

ACCELLA ERGONOMIC WORKBENCH

Hand-crank, height adjustable - 2 leg

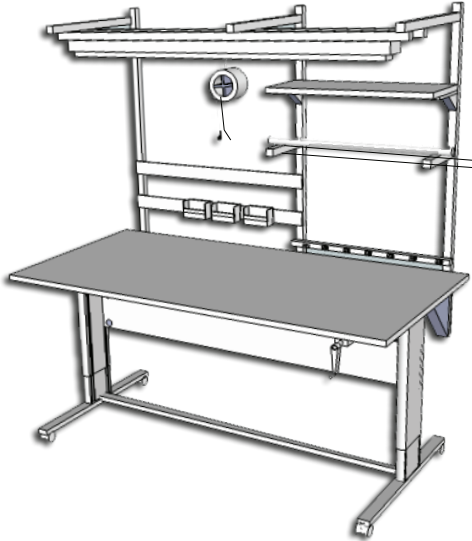

*Picture and dimension drawing shown with accessory options.

FEATURES:

- Smooth hydraulic hand-crank height adjustment
- Available with durable laminate top or ESD protective work surface
- Use 58" uprights to attach any of the optional workbench accessories
- Infinite adjustment throughout the specified range

TECHNICAL DATA:

- Standard table dimensions: 60" X 30"; 60" X 36" 72" x 30"; 72" X 36"
- Adjustment range 30" - 42"
- Workbench supports up to 400 lbs
- Extruded aluminum telescoping legs
- Heavy gauge steel powdercoat frame, Graphite Silver, Black or Almond finish

OPTIONAL ACCESSORIES:

- Rack uprights
- Light Bar with light
- Tool bar with trolley
- Extra trolley
- Tool balancers
- Electrical power strip
- Bin rail
- Supply shelf
- File drawer
- Total locking casters

MODEL	DIMENSIONS	ADJUSTMENT RANGE	START/END HEIGHT	LEG SPAN
AC IWB2L-6030	60" X 30"	12"	30", 42"	52"
AC IWB2L-6036	60" X 36"	12"	30", 42"	52"
AC IWB2L-7230	72" X 30"	12"	30", 42"	52"
AC IWB2L-7236	72" X 36"	12"	30", 42"	52"

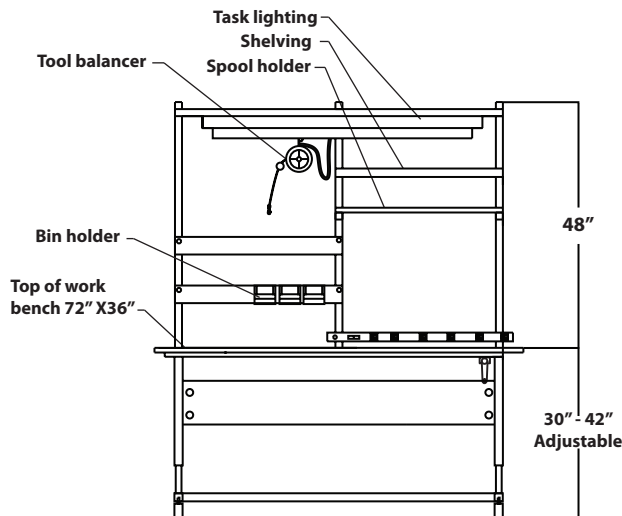

Front View

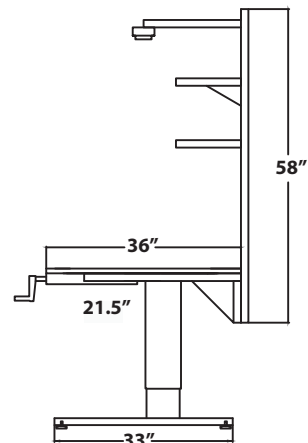

Side View