

ATTENTION

There is a potential risk of serious injury or death associated with virtually every product regardless of its type or intended use. Stander, Inc., has worked tirelessly to minimize all risks associated with its mobility aids, yet given the types of products, users, and a myriad of things outside of our control, we cannot eliminate every conceivable risk. Accordingly, a consumer must use common sense when utilizing our products, and take into account the user's overall physical and mental health.

Read all of the materials that accompany this product before it is installed or used.

LIMITED WARRANTY

Congratulations on your purchase of your Signature Life brand product. We hope that it will ease your daily living. Please read the following warranty statement for your protection.

Stander, Inc. warrants to the original purchaser that this product will be free from defects in material and/or workmanship for 1 year from the date of purchase. During the warranty period we will correct any defects in material or workmanship at no charge. All shipping cost must be paid by the original purchaser. Any replacement parts will be new and are warranted for the remainder of the original warranty or thirty (30) days from the date of shipment, whichever is longer. The original purchaser must notify Stander, Inc. during the warranty period in writing of the defect in workmanship or material. This warranty is not transferable and covers only normal use. Stander will not refund or pay for any shipping charges. The warranty does NOT cover: (1) Damage during shipment other than original shipment to retailer; (2) Damage caused by unauthorized attachments, alterations, or modifications; (3) Damage caused by the use of the product for purposes other than those for which the product was designed or intended; and (4) Damage caused by any other abuse, misuse, mishandling or misapplication.

Under no circumstances shall Stander, Inc. be liable for any special, incidental, or consequential damages based upon breach of this limited warranty, breach of contract, or strict liability.

THERE ARE NO WARRANTIES WHICH EXTEND BEYOND THOSE INDICATED HEREIN. ALL OTHER WARRANTIES, EXPRESS OR IMPLIED (INCLUDING ALL IMPLIED WARRANTIES OF MERCHANTABILITY OR FITNESS FOR A PARTICULAR PURPOSE), ARE HEREBY DISCLAIMED.

Some states do not allow limitations on how long an implied warranty lasts, so the above limitation may not apply to you. This warranty gives you specific legal right, and you may also have other rights which vary from state to state. To obtain service under this warranty, you can reach Stander, Inc. at (800) 506-9901 or (435) 755-0453.

WARNINGS

1) INSTALLATION:

- a) It is critical that all users and installers of this product read and understand all of the materials provided with this product before it is installed or used. These warnings, as well as the assembly instructions, must be carefully followed to ensure that the product is properly installed and used. Failure to install or use this product properly could result in serious injury to the user(s). If there are any questions regarding the installation or use, associated risks or anything at all regarding this product do not install or use it and contact a Stander representative at (800) 506-9901 or (435) 755-0453. We are thrilled that you have chosen to use our product so we are more than happy to answer all of your questions.
- b) Individuals who have problems with memory, sleeping, incontinence, pain, uncontrolled body movement, who walk unsafely without assistance, or who are frail, weak, confused, restless, under the influence of drugs or any substance that could impact their balance or judgment are at a higher risk. You should first consult a physician before using this product.
- c) Improper installation of this product significantly increases the risk of injury.
- d) This product should not be used on any light weight furniture that would allow the product to become dislodged or move under during use of the product.
- e) Individuals who have size or weight conditions are at a higher risk of injury due to personal mobility issues and the ability of the product to be supported under the furniture.
- f) Children should not be allowed to hang on or play with this product.
- g) This product is not intended to carry the full weight of an individual. This product is only intended to provide balance and support while sitting and standing.
- h) This product may shift its position over time. Inspect this product frequently to ensure it is installed properly.

2) AGREEMENT BETWEEN INSTALLER/USER(S) AND STANDER INC.:

- a) If the installer/user(s) choose to use this product, it is understood between the installer/user(s) AND Stander Inc., that the installer/user(s) accept the risks associated with using this product. Since these conditions are subjective and Stander Inc. has no control over who chooses to use this product, the installer/user(s) agree to be liable for their decisions when using this product.

3) CONSUMER RIGHTS AND ARBITRATION AGREEMENT:

- a) This arbitration agreement ("Agreement") affects your legal rights and remedies by providing that disputes between you and the manufacture of this product ("Stander"), must be resolved through binding arbitration, rather than in a court. Please read this agreement carefully as you accept the terms of this agreement by assembling and using this product. If you do not agree to the terms of this agreement, return the product to the location of purchase for a refund.
- i) **RESOLUTION OF CLAIMS OR DISPUTES.** Any claim or dispute between you and Stander arising out of or relating in any way to the Product or this Agreement shall be resolved through final, binding arbitration. This arbitration obligation applies regardless of whether the claim or dispute involves a tort, fraud, misrepresentation, product liability, negligence, violation of a statute, or any other legal theory. Both you and Stander specifically acknowledge and agree that you waive your right to bring a lawsuit based on such claims or disputes and to have such lawsuit resolved by a judge or jury.
- ii) **LIMITATION OF LEGAL REMEDIES.** All arbitrations under this Agreement shall be conducted only on an individual (and not a class-wide) basis and an arbitrator shall have no authority to award class-wide relief. You acknowledge and agree that this Agreement specifically prohibits you from commencing arbitration proceedings as a representative of others or joining in any arbitration proceedings brought by any other person. iii) **ARBITRATION PROCEDURES.**
- (1) Before commencing any arbitration proceedings under this Agreement, you must first present the claim/dispute to Stander by calling (800) 506-9901 or (435) 755-0453, providing requested contact information and allowing Stander the opportunity to resolve it. If your claim or dispute is not resolved within sixty (60) days, you may commence arbitration proceedings in accordance with the terms of this Agreement.
- (2) The arbitration of claim(s)/dispute(s) under this Agreement shall be pursuant to the American Arbitration Association's ("AAA") United States Commercial Dispute Resolution Procedures and Supplementary Procedures for Consumer Related Disputes (see www.adr.org for their rules and procedures).
- (3) The arbitration of any claim/dispute under this Agreement shall be in the State of Utah.
- (4) All administrative expenses of arbitration proceedings under this Agreement shall be divided equally between you and the Company, except that: (a) if the claims/dispute subject to the arbitration proceedings is less than ten thousand dollars (US\$10,000), you will be responsible for no more than one hundred twenty-five dollars (US\$125) in administrative expenses; (b) if the claim/dispute subject to the arbitration proceedings is more than ten thousand dollars (US\$10,000) but less than seventy-five thousand dollars (US\$75,000), then you will be responsible for no more than three hundred seventy-five dollars (US\$375) in administrative expenses; and (c) if the claim/dispute subject to the arbitration proceedings is more than seventy-five thousand dollars (US\$75,000), then you will be responsible for administrative expenses in accordance with the Commercial Fee Schedule provided by the AAA. You acknowledge and agree that each party shall pay the fees and costs of its own counsel, experts and witnesses.
- iv) **CHOICE OF LAW & SEVERABILITY.** This Agreement shall be governed by the United States Federal Arbitration Act and the laws of the state of Utah. If any provision of this Agreement is declared or found to be unlawful, unenforceable or void, such provision will be ineffective only to the extent that it is found unlawful, unenforceable or void and the remainder shall remain fully enforceable.

**⚠ WARNING
ENTRAPMENT AND FALL HAZARD**

- Do NOT use or place near adult beds, children's beds, bunk beds, water beds, or inflatable beds. Use of product on any bed may result in risk of entrapment.
- People with Alzheimer's disease or dementia, or those who are sedated, confused, or frail, are at increased risk of entrapment and falls.
- Failure to comply with these conditions could put the user(s) at risk of entrapment or falling.



Instructions:

1. Remove all components from the box and verify all parts are included as shown in Figure 1.

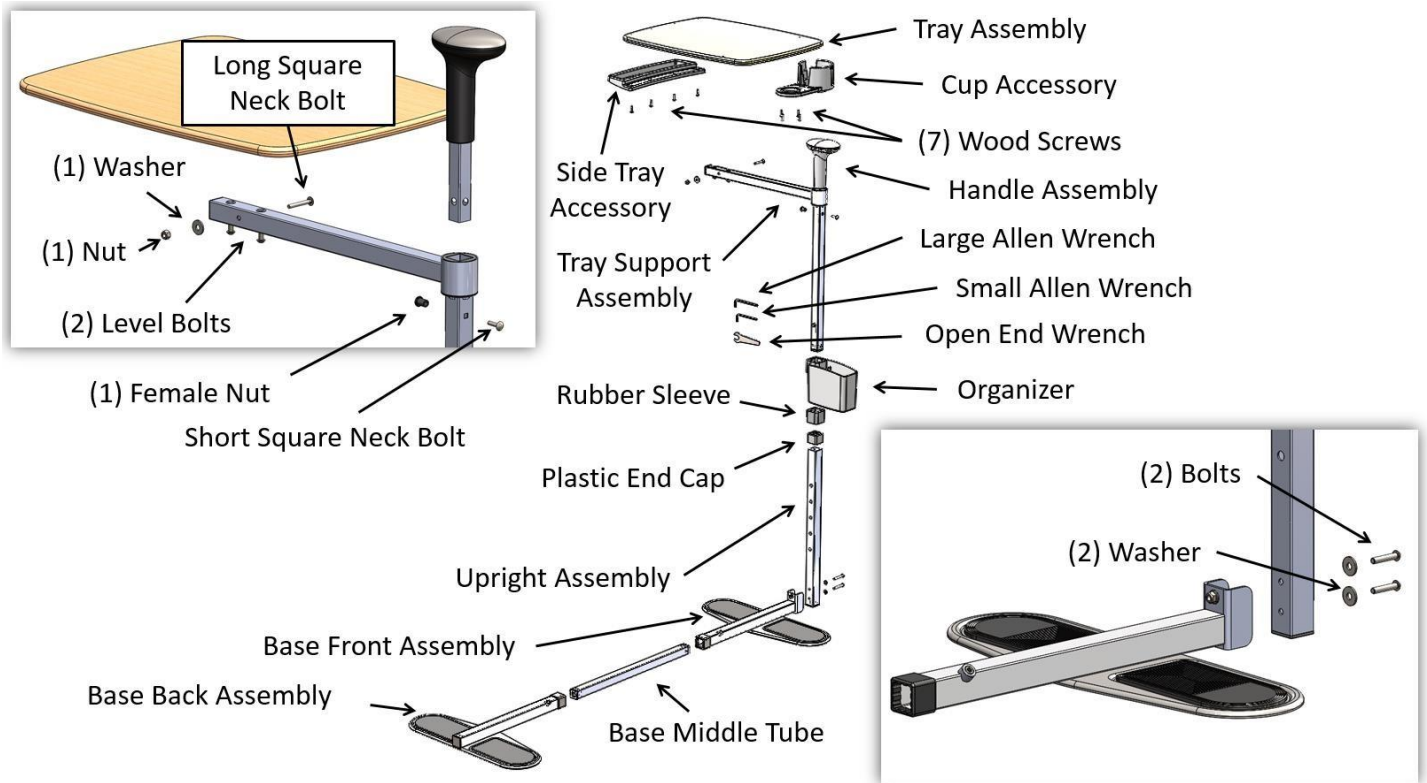

FIGURE 1

2. Slide Base Front Assembly and Base Back Assembly onto the Base Middle Tube as shown in Figure 2.

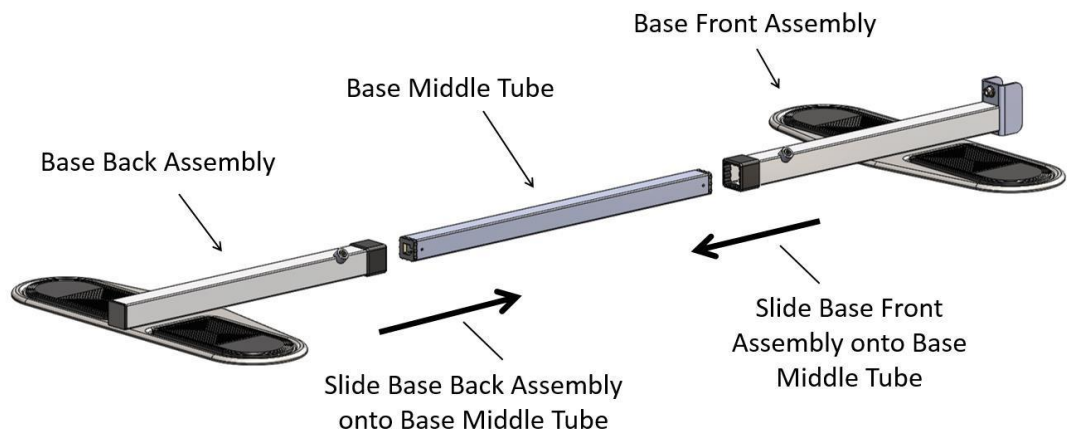

FIGURE 2

3. Position the Rubber foot pads at the same distance of the Furniture legs spacing and tighten the Set Screws with the Large Allen Wrench as shown in Figure 3. The Furniture legs should sit on the center of the Rubber foot pads.

NOTE: The Base Middle Tube should engage the Base Front Assembly and the Base Back Assembly approximately 4 inches on each side in order for the Set Screws to properly engage.

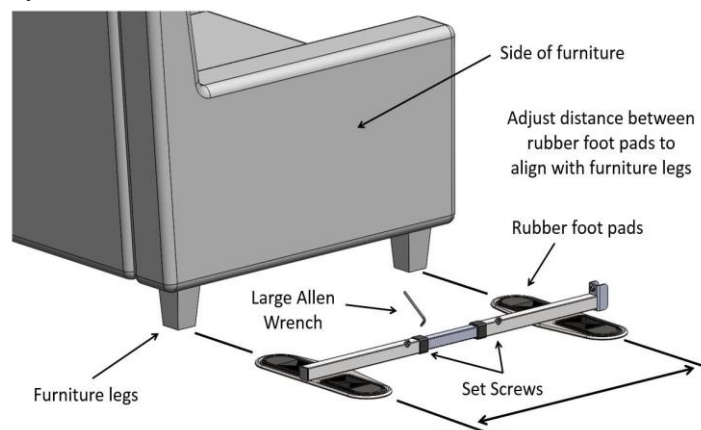

FIGURE 3

4. Attach the Upright Assembly to the Base Front Assembly with the Small Allen Wrench, 2 Bolts, and 2 Washers as shown in Figure 4.

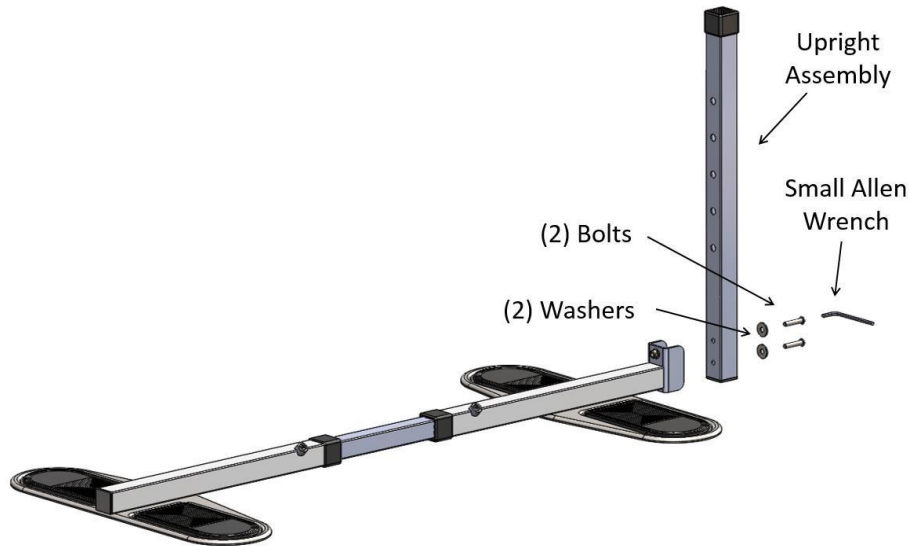

FIGURE 4

5. Using the Open End Wrench, attach the Tray Assembly to the Tray Support Assembly with the Long Square Neck Bolt, 1 Washer, and 1 Nut as shown in FIGURE 5.

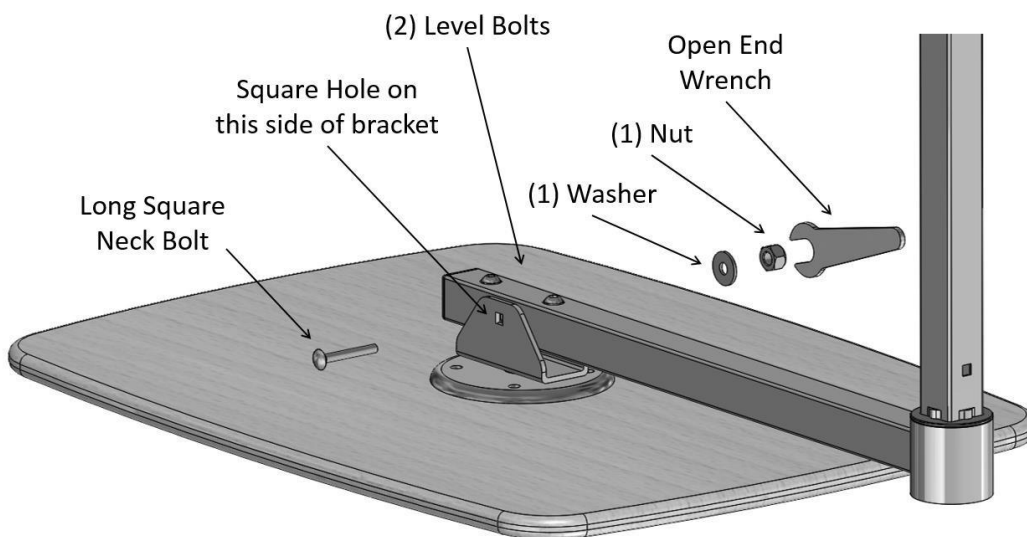

FIGURE 5

6. Attach Cup Accessory AND Side Tray to bottom of Tray Assembly with 7 Wood Screws as shown in FIGURE 6 and FIGURE 7.

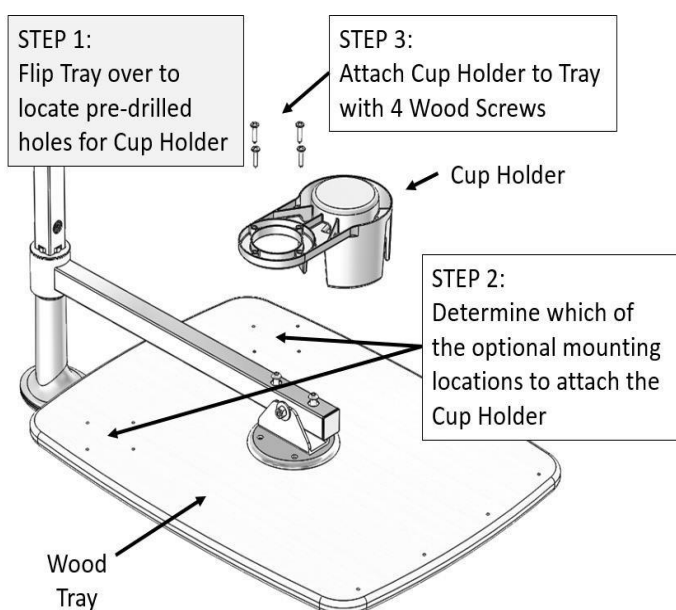

FIGURE 6

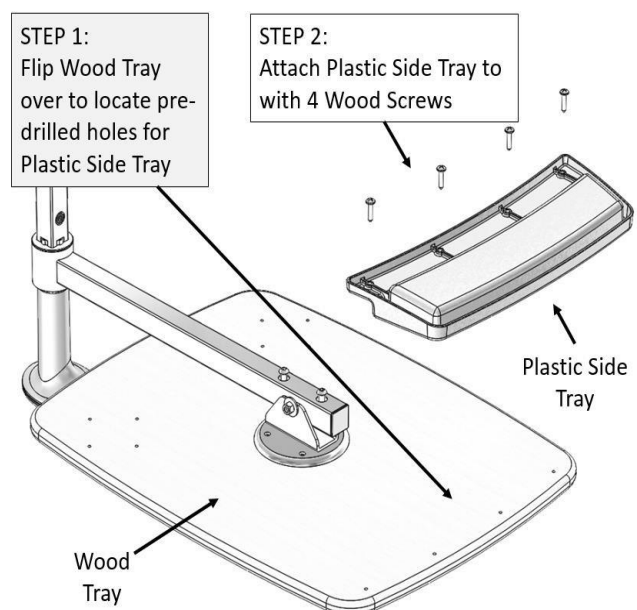

FIGURE 7

7. Install the Organizer by following the steps described in FIGURE 8 as shown below. **NOTE:** Remove the existing Plastic End Cap on the Upright Assembly before installing the Organizer.

After Organizer is installed, depress the Spring Pin in the Tray Support Assembly and slide the Tray Support Assembly into the Upright Assembly after installing the Organizer.

IMPORTANT: Allow the Spring Pin to engage any of the holes in the Upright Assembly as shown in FIGURE 8.

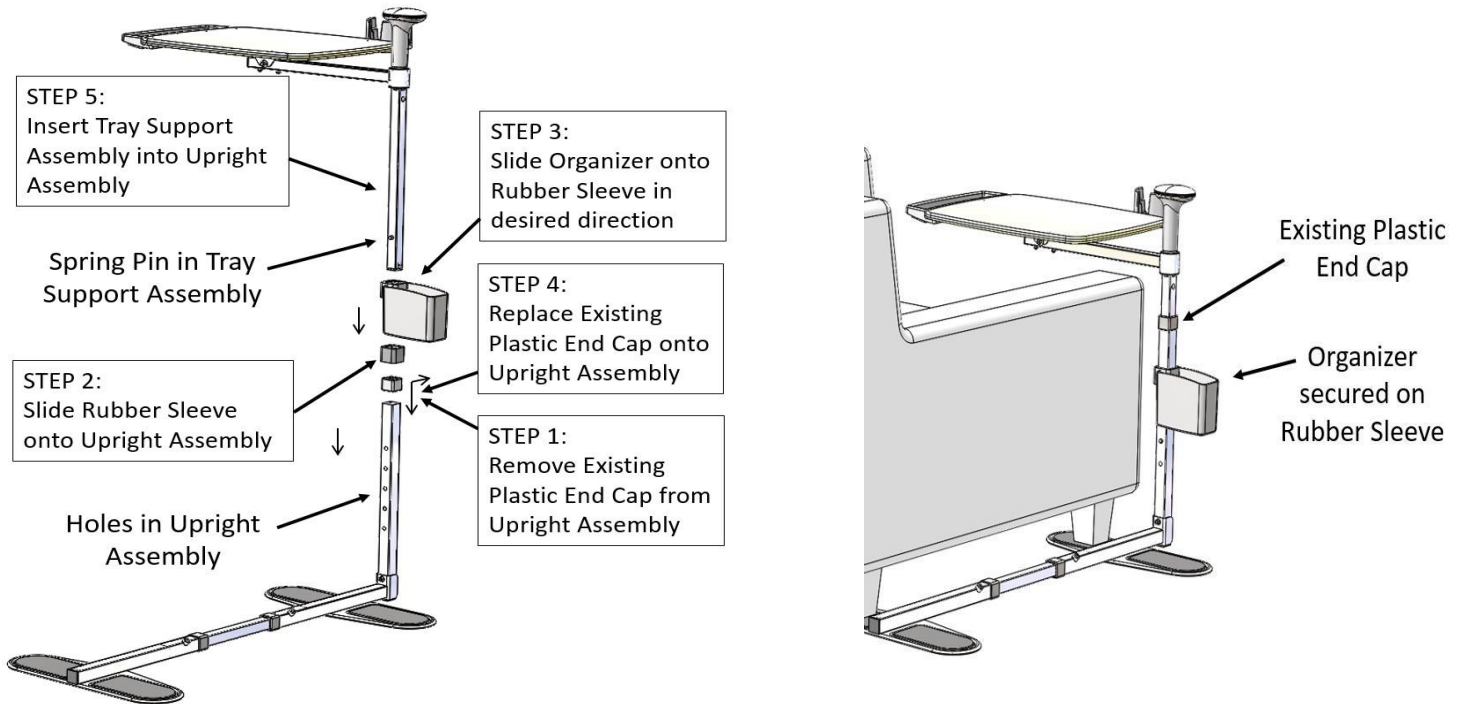

FIGURE 8

8. Adjust the Height of the Tray Support Assembly to pivot above the Furniture arm rest. **NOTE:** The Furniture legs can be positioned on either set of the Rubber foot pads as shown in FIGURE 9 and FIGURE 10.

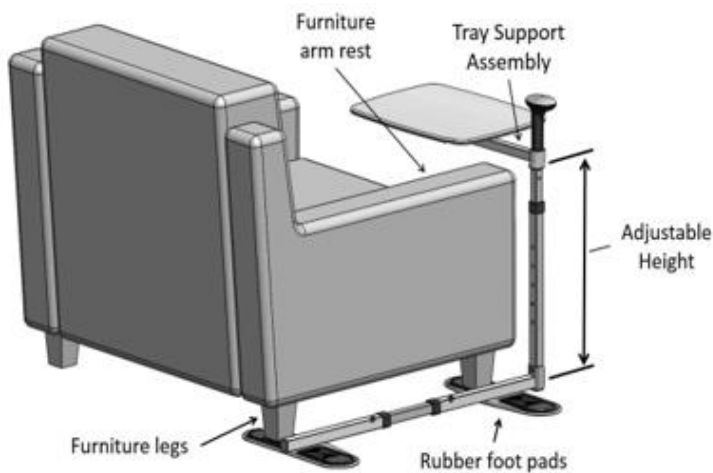

FIGURE 9

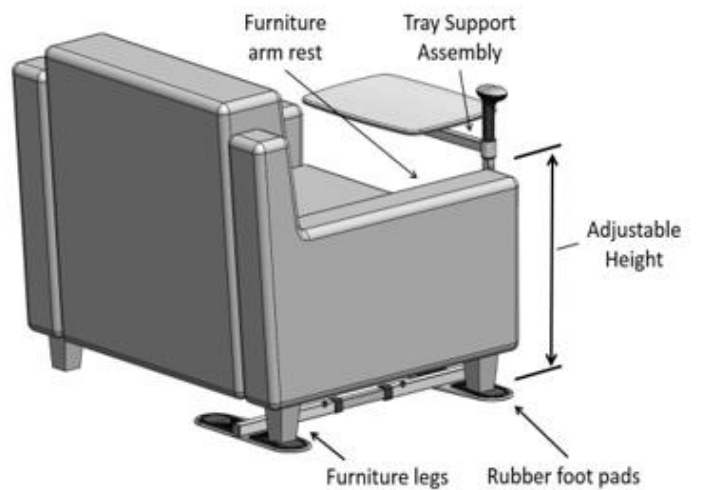

FIGURE 10

9. Attach the Handle Assembly to the Tray Support Assembly with the Small Allen Wrench, Female Nut, Short Square Neck Bolt as shown in Figure 11. **NOTE:** Short Square Neck Bolt must be inserted into the square hole of the Tray Support Assembly.

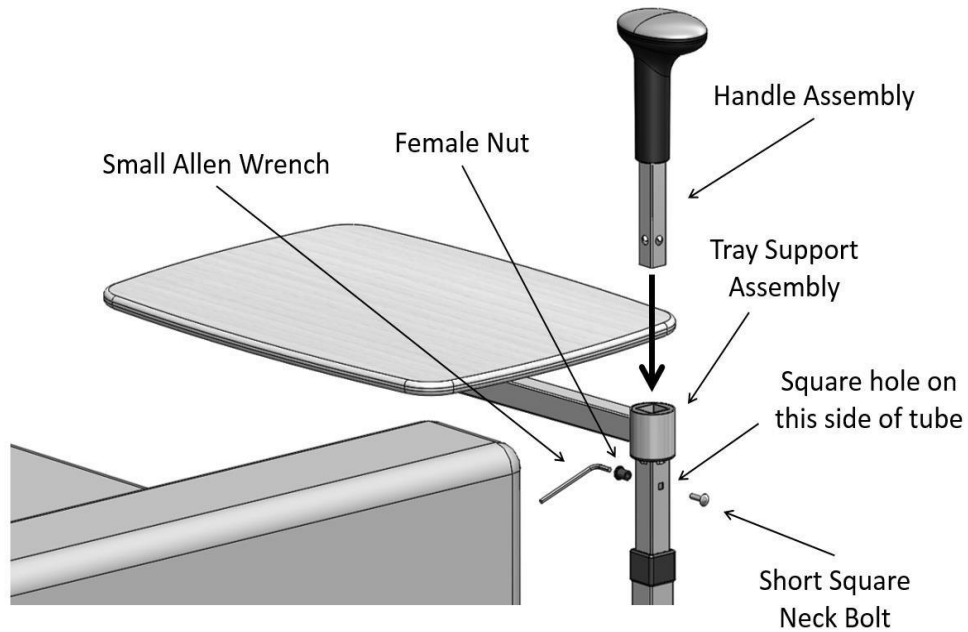

FIGURE 11

10. The Tray Assembly can be leveled by using the Small Allen Wrench. Loosen the leveling screw on the high side and then tighten the screw on the low side. When the Tray Assembly is level, tighten each screw equally as shown in FIGURE 12.

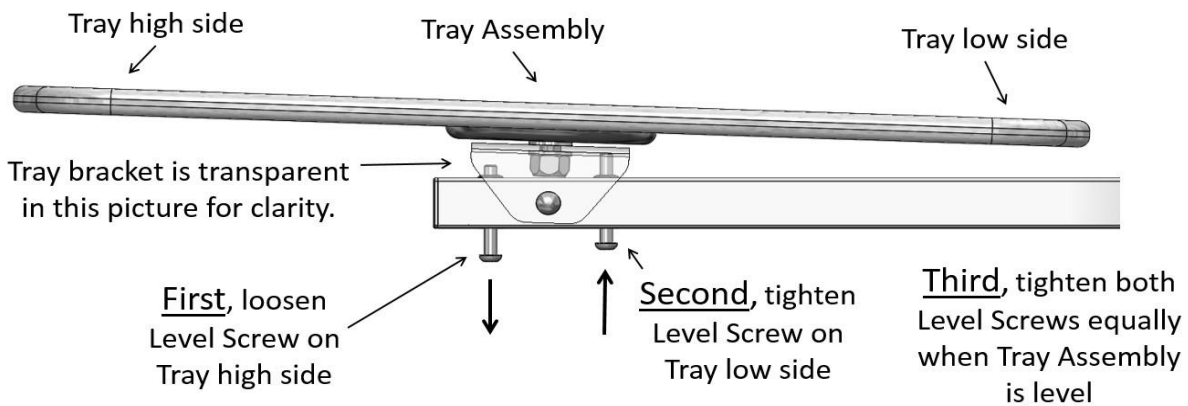
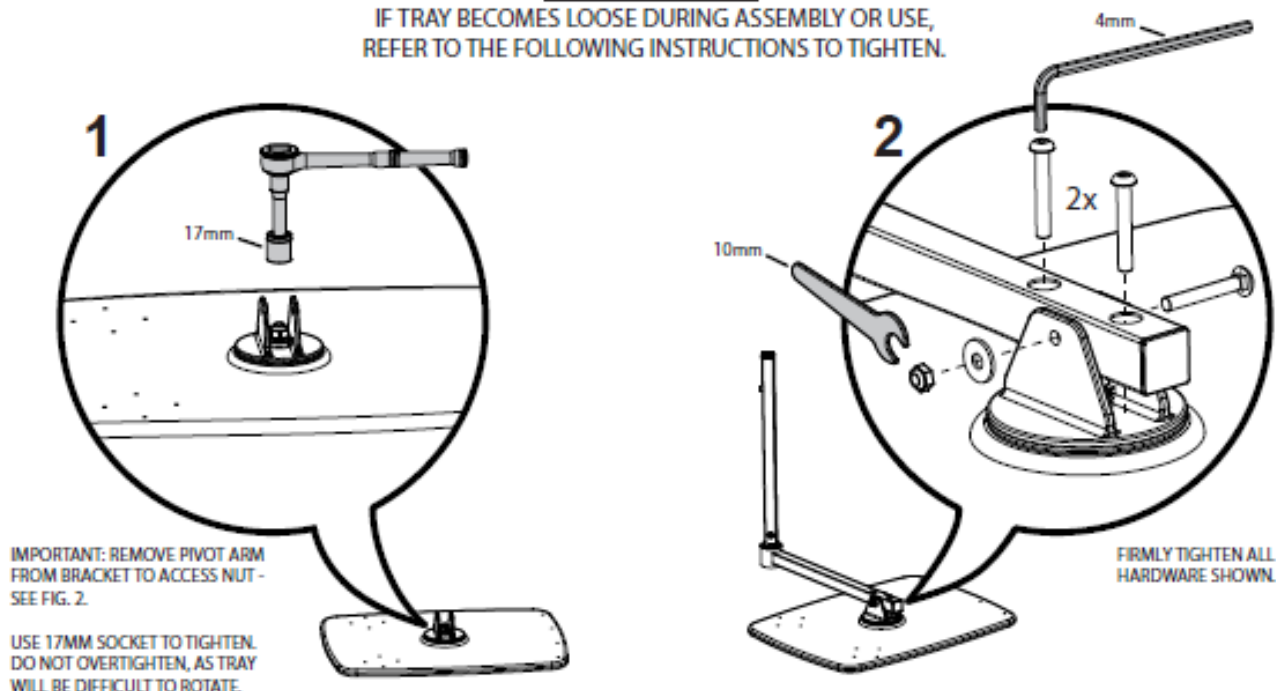

FIGURE 12

ATTENTION:
IF TRAY BECOMES LOOSE DURING ASSEMBLY OR USE, REFER TO THE FOLLOWING INSTRUCTIONS TO TIGHTEN.



IMPORTANT: REMOVE PIVOT ARM FROM BRACKET TO ACCESS NUT - SEE FIG. 2.
USE 17MM SOCKET TO TIGHTEN. DO NOT OVERTIGHTEN, AS TRAY WILL BE DIFFICULT TO ROTATE.

FIRMLY TIGHTEN ALL HARDWARE SHOWN.

For more detailed instructions see video at:
<https://signaturelife.com/8800-video>
or contact us at 800-506-9901, or email support@signaturelife.com

