



H Series 75 Gallon Mobile Whirlpool H-75-M



Product photo/image above may show some available options

H-75-M Mobile Whirlpool is recommended for shallow or deep body immersion offering complete coverage of the lower extremities as well as the lower back and hip.

Tank Capacity is 75 gallons.

Whirlpool Tank is 42"L x 20"W x 28"D and is seamless welded construction, fabricated from heavy gauge, type 304 stainless steel, polished to a satin finish. Tank rim is reinforced with a concealed stainless steel rod. Tank is fitted with an auxiliary drain valve. Tank bottom is a seamless, rounded covered design to minimize bacteria buildup.

Heavy Duty Swivel Casters support all mobile models. Rear pair of casters are lockable for stabilizing whirlpool during treatment.

Turbine Raising and Lowering Device permits adjustment of desired height and direction of water agitation towards the area of the body to be treated. It is spring balanced and provided with a locking device.

Turbine Assembly functions both as agitator and emptying device. It is equipped with Underwriters Laboratory listed 1/2 HP jet pump motor protected with an ABS plastic shell, and automatic thermal overload protector, and lifetime-sealed bearings. All parts contacting the water are stainless steel, chrome plated brass or bronze.

Thermometer is provided with a dual scale, adjustable calibration, and a stem inserts into a retainer to prevent rattle during whirlpool agitation.

GUIDE SPECIFICATIONS

Provide Mobile Whirlpool (specify model number and options) with a 75-gallon capacity, 42"L x 20"W x 28"D. Whirlpool shall be fabricated from heavy gauge, type 304 stainless steel. Construction shall be seamless welded and exposed surfaces shall be polished to satin finish. Tank shall have a reinforced rim and shall be fitted with an auxiliary drain valve. Bottom of tank shall be a seamless, rounded covered design to minimize bacteria build up. Whirlpool shall have heavy duty swivel casters with locking device on rear pair of casters. Provide a turbine assembly with raising and lowering device which functions both as agitator and emptying device, permits adjustment of desired height, direction of water agitation, and can be locked into place. Turbine assembly shall be UL listed 1/2 HP jet pump motor with automatic thermal overload protector, and lifetime-sealed bearings. Provide a thermometer with a stem retainer to prevent rattle when whirlpool is in operation.

Hi-Boy Whirlpools

MODEL NUMBER AND OPTION SELECTIONS

Series

- H Hi-Boy Series

Capacity

- 75 Gallons

Type

- M Mobile Whirlpool

Suffix Options (See Whirlpool Option Section for Details)

- ADH Auxiliary Drain Hose Assembly
- AHC1 Adjustable High Chair with Casters
- AHC2 Adjustable High Chair with Rubber Tips
- ARS Arm Rest Support
- AS1 Adjustable Suspension Seat
- CTS1 Combination Table with Side Seats

- EG Enviro Glaze Color Powder Coating - Specify Color: _____

(Special Finish Consult Factory)

- GFI Ground Fault Interrupter
- PCS Pump Cover Strainer
- PHS2 Patient Handling System (Chair Type)
- RHG Rubber Hand Grips
- SDP Separate Drain Pump
- TTS1 Tank Top Seat
- WLS Water Level Sensor

Turbine Assembly

Electrical on standard turbine supplied is 115 V 60 Hz
if 220 V is required please specify:

- 50 Hz
- 60 Hz

Note: Electrical requirements are 8 Amps / 115 Volts/ 60Hz/ 3 Pole GFI Receptacle.

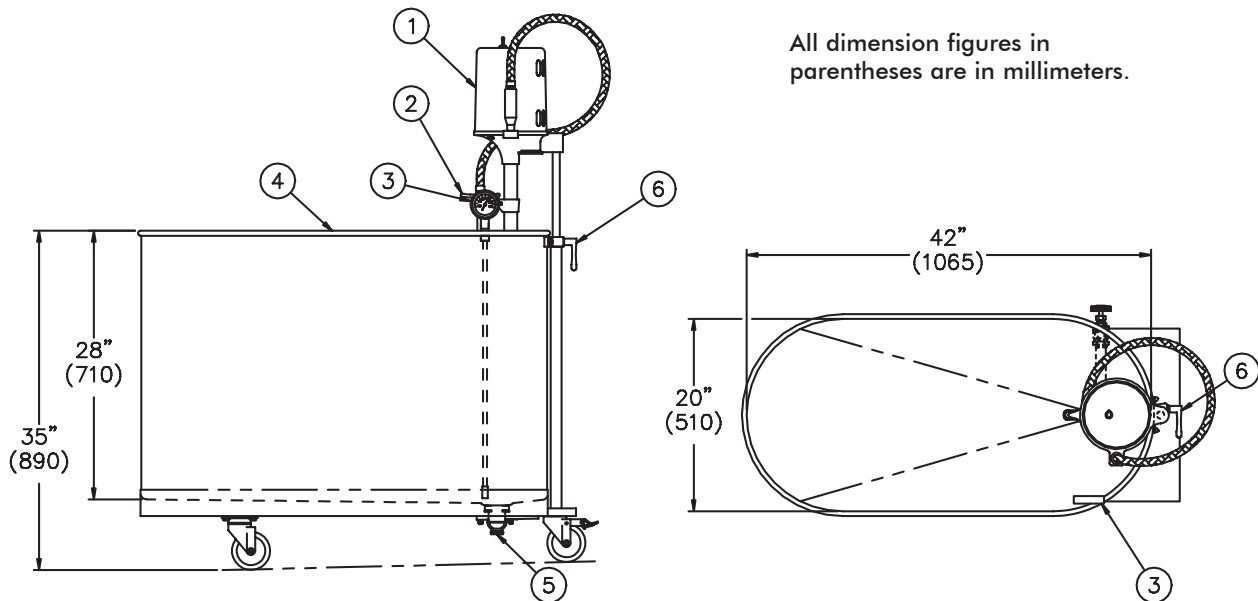

MOBILE H-75-M SERIES WHIRLPOOL

NOTE:

1. 1/2 hp Jet Pump Motor.
2. Variable Pressure Control.
3. Thermometer.
4. Stainless Steel Tank.

5. Auxiliary Drain Valve.
6. Turbine Raising & Lowering Device.

SELECTION SUMMARY & APPROVAL FOR MANUFACTURING

Model Number & Options _____ Quantity _____
 Company _____ Date _____
 Contact _____ Title _____
 Approval for Manufacturing/Signature _____