

Use



L Series 75 Gallon Mobile Whirlpool L-75-M



Product photo/image above may show some available options

L-75-M Mobile Whirlpool is recommended for treatment of extremities, hip and back area. It is ideal for pediatric and geriatric applications imparting a greater degree of patient comfort and safety.

Tank Capacity is 75 gallons.

Whirlpool Tank is 52"L x 24"W x 18"D and is seamless welded construction, fabricated from heavy gauge, type 304 stainless steel, polished to a satin finish. Tank rim is reinforced with a concealed stainless steel rod. Tank bottom is a seamless, rounded covered design to minimize bacteria buildup.

Heavy Duty Swivel Casters support all mobile models. rear pair of casters are lockable for stabilizing whirlpool during treatment.

Turbine Raising and Lowering Device permits adjustment of desired height and direction of water agitation towards the area of the body to be treated. It is spring balanced and provided with a locking device.

Turbine Assembly functions both as agitator and emptying device. It is equipped with Underwriters Laboratory listed 1/2 HP jet pump motor protected with an ABS plastic shell, and automatic thermal overload protector, and lifetime-sealed bearings. All parts contacting the water are stainless steel,

chrome plated brass or bronze.

Drain options auxiliary drain valve on the bottom of the unit. The **L-75-M-DS** is constructed with an integral sump which reduces residual water and eliminates the need for a drain.

Thermometer is provided with a dual scale, adjustable calibration, and a stem inserts into a retainer to prevent rattle during whirlpool agitation.

GUIDE SPECIFICATIONS

Provide Mobile Whirlpool (specify model number and options) with a 75-gallon capacity, 52"L x 24"W x 18"D. Whirlpool shall be fabricated from heavy gauge, type 304 stainless steel. Construction shall be seamless welded and exposed surfaces shall be polished to satin finish. Tank shall have a reinforced rim. Bottom of tank shall be a seamless, rounded covered design to minimize bacteria build up. Whirlpool shall have heavy duty swivel casters with locking device on rear pair of casters. Provide a turbine assembly with raising and lowering device which functions both as agitator and emptying device, permits adjustment of desired height, direction of water agitation, and can be locked into place. Turbine assembly shall be UL listed 1/2 HP jet pump motor with automatic thermal overload protector, and lifetime-sealed bearings. Provide a thermometer with a stem retainer to prevent rattle when whirlpool is in operation.



Member of
U.S. Green
Building Council



Recycleable
Product

Lo-Boy Whirlpools

MODEL NUMBER AND OPTION SELECTIONS

Series

- L Lo-Boy Series

Capacity

- 75 Gallons

Type

- M Mobile Whirlpool
- M-DS Mobile Whirlpool with Sump

Suffix Options (See Whirlpool Option Section for Details)

- ADH Auxiliary Drain Hose Assembly
- ALC Adjustable Low Chair
- ALS Adjustable Low Stool
- ARS Arm Rest Support
- AS3 Adjustable Suspension Seat
- CTS3 Combination Table with Side Seats

- EG Enviro Glaze Color Powder Coating - Specify Color: _____

(Special Finish Consult Factory)

- GFI Ground Fault Interrupter
- HR Head Rest, Adjustable
- PCS Pump Cover Strainer
- PHS2 Patient Handling System (Chair Type)
- RHG Rubber Hand Grips
- TTS2 Tank Top Seat

Note: Separate Drain and Overflow Assembly (-SDO) is not available with Model L-75-M.

Turbine Assembly

Electrical on standard turbine supplied is 115 V 60 Hz
if 220 V is required please specify:

- 50 Hz
- 60 Hz

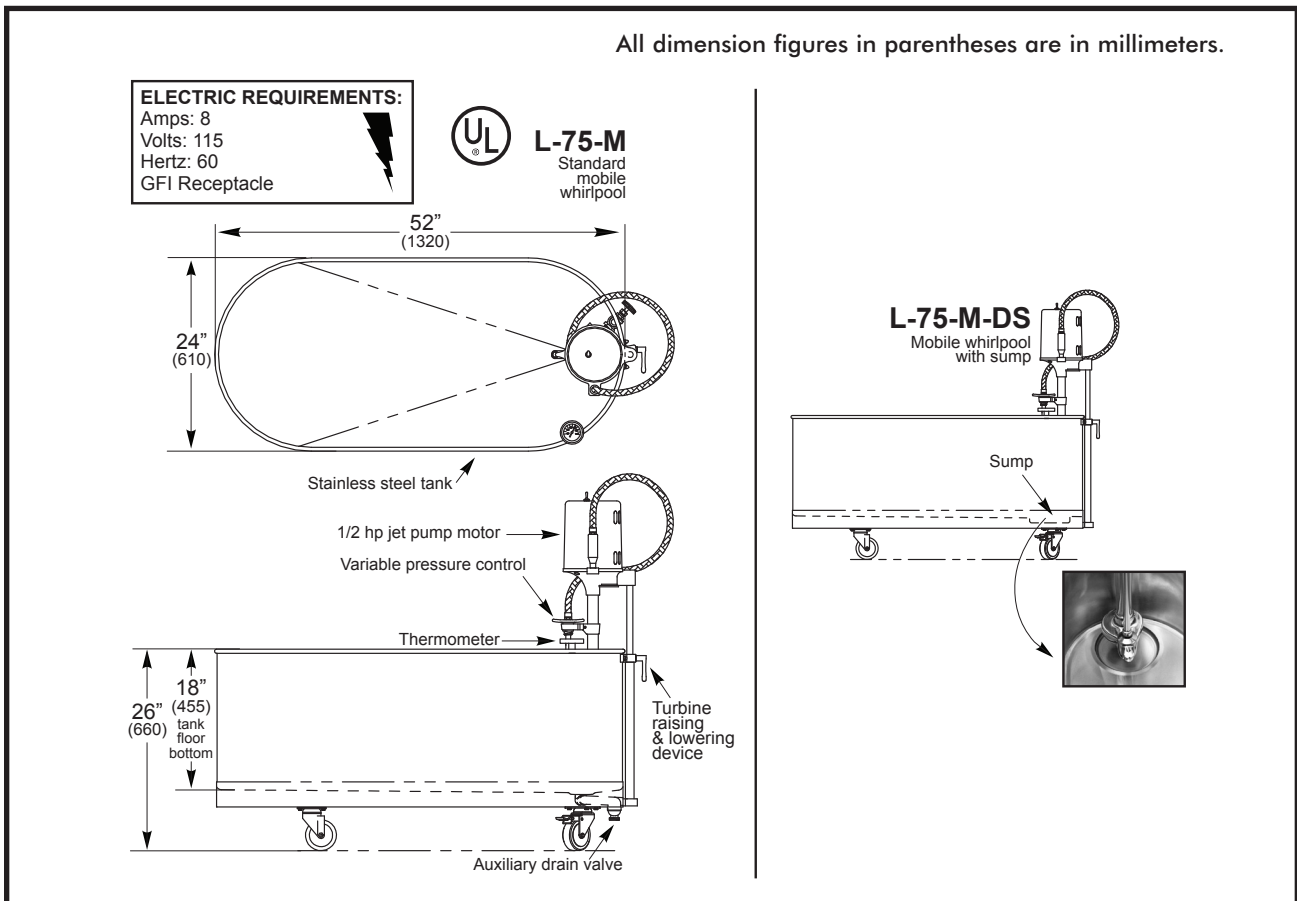

SELECTION SUMMARY & APPROVAL FOR MANUFACTURING

Model Number & Options _____ Quantity _____

Company _____ Date _____

Contact _____ Title _____

Approval for Manufacturing/Signature _____