

INSTRUCTIONS FOR USE

Tenor



WARNING

To avoid injury, always read this Instructions for Use and accompanied documents before using the product.



Mandatory to read the Instructions for Use

Design Policy and Copyright

® and ™ are trademarks belonging to the Arjo group of companies.

© Arjo 2018.

As our policy is one of continuous improvement, we reserve the right to modify designs without prior notice. The content of this publication may not be copied either whole or in part without the consent of Arjo.

Content

Safety instructions	3
Read Before Use	3
Intended Use	3
Operational Life	3
Bariatric Slings Guidance	4
Product description	5
Parts referred to in this manual	5
Controls and functions	6
Control Handset	6
Dual control switch	6
Emergency Stop Button (red)	6
Power on / Reset button (green)	6
Power off button (red)	6
Automatic cut out	6
System failure lower override	6
Automatic stop function	7
Battery discharge indicator	7
Powered adjustable width chassis legs	7
Scale (optional)	7
Using your Tenor	8
Checklist before use	8
Preparation	8
Before approaching the resident	8
To lift a resident from a chair	8
To return resident back to a chair	9
To lift a resident from a bed	10
To lift a resident from the floor	12
Battery charging	13
Care of your TENOR	15
Servicing Advice	15
Slings	16
Environmental Advice	16
Labels	17
Key to labels	17
Technical specification	18
Component Weights	18
Maximum Lifting Capacities (Safe Working Load - SWL)	18
Electrical	18
Environment	18
Maximum sound power level	19
Hoist Dimensions	19
Troubleshooting / Problem Solving	21
Preventive Maintenance Schedule	23
Arjo Slings	23
Arjo Battery Charger	23
Arjo Tenor	23
Checks to be performed by qualified Arjo personnel	24
Electromagnetic Compatibility (EMC)	25

Safety instructions



READ BEFORE USE

Before using your *Tenor*, familiarise yourself with the various parts and controls as illustrated in this document. Read this whole manual thoroughly before operating your *Tenor* in order to prevent injury or damage to the product.

Symbols and definitions used in this manual:



CAUTION

Failure to follow these instructions may cause damage to the product.



WARNING

Failure to follow these instructions may result in injury to yourself or to others.

INTENDED USE

Tenor is a mobile passive lift, intended to be used on horizontal surfaces for lifting and transfer in hospitals, nursing homes or other health care facilities.

To describe which residents may be lifted using an Arjo hoist, a resident gallery has been created by Arjo. The residents that can be transferred with a *Tenor* have been named Doris (D) and Emma (E).

Tenor has been designed to lift Doris, who:

- Sits in wheelchair
- Has no capacity to support herself at all
- Cannot stand unsupported and is not able to bear weight, not even partially
- Is dependent on carer in most situations

Tenor has been designed to lift Emma, who:

- Is a passive resident
- Might be almost completely bed ridden
- Is often stiff and has contracted joints
- Is totally dependent

This equipment shall always be handled by a trained caregiver and in accordance with the instructions outlined in this Instruction for Use. *Tenor* should only be used for the purpose specified in this Instructions for Use. Any other use is prohibited.

OPERATIONAL LIFE

Unless stated otherwise, the operational life of the *Tenor* is ten (10) years, as long as the required preventive maintenance is carried out in accordance with the care and maintenance instructions in this user manual. The *Tenor* will not be suitable for use if it is damaged.

The operational life of the sling and of the consumable parts e.g. batteries, depends on the actual use conditions. Therefore, before use, always make sure that the sling, loops, cords and straps do not show any sign of fraying, tearing or other damage and that there is no damage (e.g. cracking, bending, breaking) to the attachment clips. If any such damage is observed, do not use the sling.



WARNING

When using the *Tenor*, only use the slings as described in the list on the next page.

The scale (if fitted) has been designed to weigh residents.



WARNING

Do not overload the *Tenor* beyond the approved maximum lifting capacity (Safe Working Load) of 320 kg (705 lbs).



CAUTION

Although manufactured to a high standard, the *Tenor* and accessories should not be left for extended periods in humid or wet areas.

Do not, under any circumstances, spray the *Tenor* or accessories (excluding sling) with water e.g. under the shower.

Safety instructions



WARNING

Before attempting to raise a resident, a full clinical assessment of the resident's condition and suitability must be carried out by a qualified person on the individual resident to determine if it is advisable that he/she will be lifted and/or transferred using a *Tenor*.



WARNING

If FLITES (disposable sling) are to be used with the *Tenor*, then always refer to the separate operating instructions for FLITES as well as these instructions before using.

BARIATRIC SLINGS GUIDANCE

Part number	Sling Size	Edge binding colour	Safe Working Load
MAA8000-M	M	Yellow	454 kg/1 000 lb
MAA8000-L	L	Green	454 kg/1 000 lb
MAA8000-XL	XL	Blue	454 kg/1 000 lb
MAA8000-XXL	XXL	Terracotta	454 kg/1 000 lb
MAA8010-M	M	Yellow	454 kg/1 000 lb
MAA8010-L	L	Green	454 kg/1 000 lb
MAA8010-XL	XL	Blue	454 kg/1 000 lb
MAA8010-XXL	XXL	Terracotta	454 kg/1 000 lb
MAA8020-M	M	Yellow	454 kg/1 000 lb
MAA8020-L	L	Green	454 kg/1 000 lb
MAA8020-XL	XL	Blue	454 kg/1 000 lb
MAA8020-XXL	XXL	Terracotta	454 kg/1 000 lb
MAA8030-M	M	Yellow	454 kg/1 000 lb
MAA8030-L	L	Green	454 kg/1 000 lb
MAA8030-XL	XL	Blue	454 kg/1 000 lb
MAA8030-XXL	XXL	Terracotta	454 kg/1 000 lb

If the resident's weight falls into two sizes or if there is any doubt on choosing the right size slings, always go for the smaller size sling first.

This resident sling guide is only an approximation, other factors which must be considered when selecting the appropriate sling are: resident's distribution of body weight (i.e. hips, thighs, upper body); resident's height, torso length; resident's physical condition (i.e. amputee, contractions, etc.).



WARNING

The *Tenor* resident must only be lifted using a bariatric sling.

Product description

Parts referred to in this manual

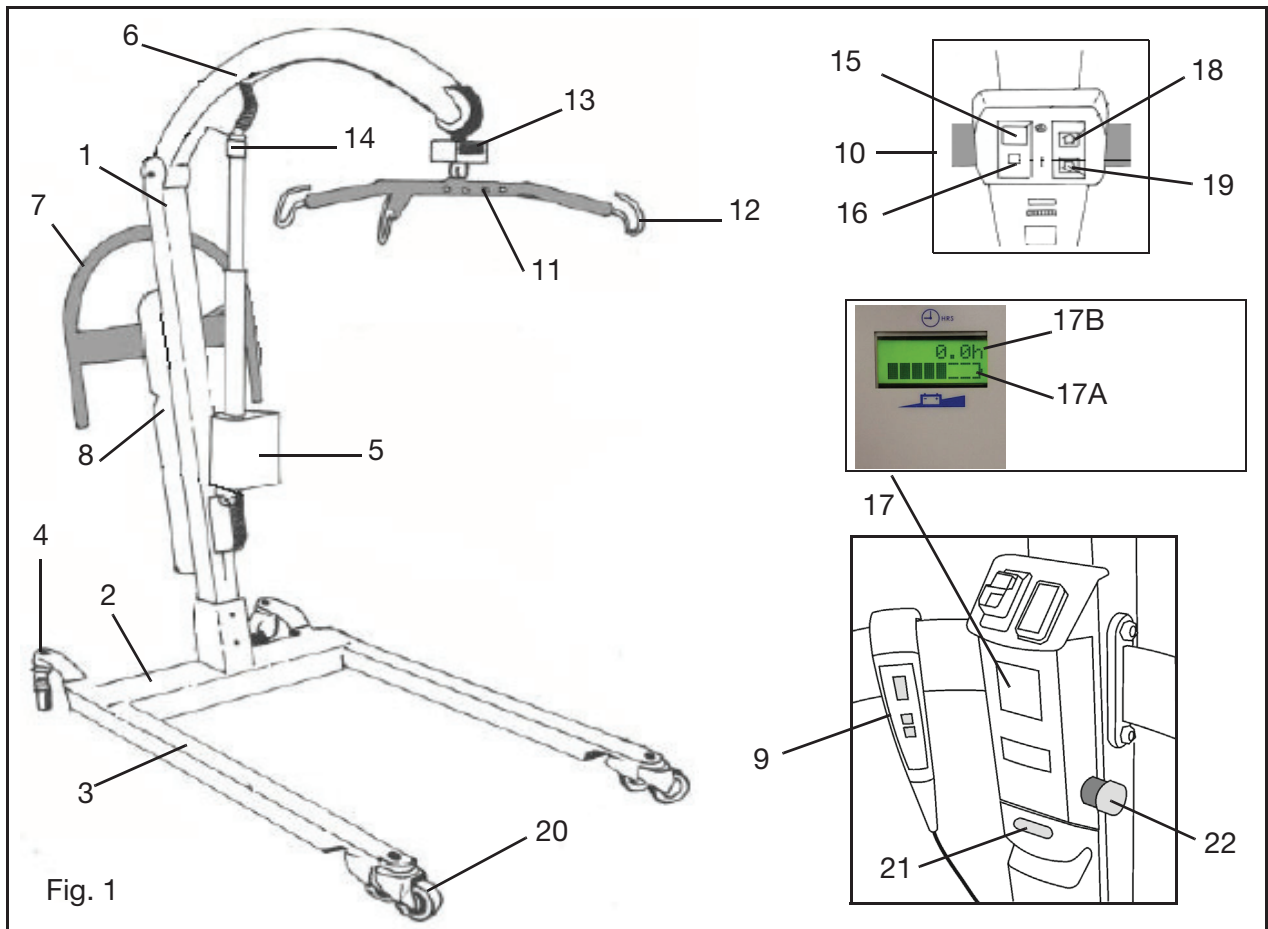

- | | |
|--|---|
| 1. Mast | 13. Scale unit and display (if fitted) |
| 2. Chassis | 14. System failure lower override |
| 3. Adjustable width chassis legs | 15. Power off button |
| 4. Rear castors (braked) | 16. Power on / Reset button |
| 5. Lift actuator | 17. LCD |
| 6. Jib | 17A: Battery discharge indicator |
| 7. Manoeuvring handle | 17B. Hour/Cycle meter |
| 8. Battery pack | 18. Dual control switch for raising UP |
| 9. Hand control (for raising and lowering) | 19. Dual control switch for lowering DOWN |
| 10. Electric / Battery compartment | 20. Front castor |
| 11. Spreader bar | 21. Battery release button |
| 12. Sling attachment hooks | 22. Emergency stop button |

Product description

CONTROLS AND FUNCTIONS

Control Handset: Press the appropriate button on the control handset to raise / lower the jib and to move the spreader bar. A small direction arrow is printed next to each button for function identification (See Fig. 2).

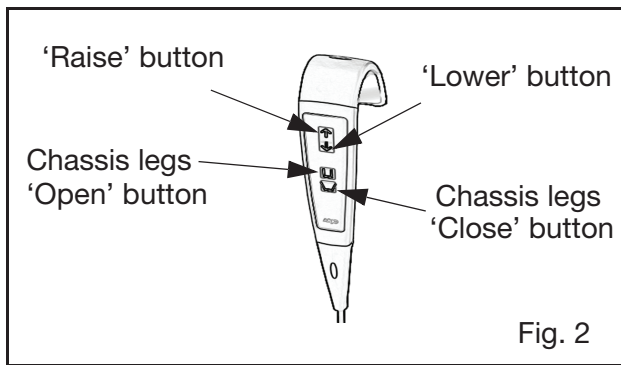

If pressure is released during any function, powered motion will stop immediately. Do not drop the handset into water, e.g. bath.

When not in use, the handset can be kept ready for use by hooking it over the loop at the rear of the mast.

Dual control switch: The raising / lowering of the jib can also be controlled from this switch, situated on the top of the electronics / battery compartment on the mast. Arrows on the switch are for function identification (See inset to Fig. 1). This switch will function, even if the handset cable has been unplugged.

Emergency Stop Button (red): If, in an emergency, you have to immediately stop any powered movement (other than by releasing pressure on the button on the handset) press the emergency stop button situated on the right hand side of the electronics / battery compartment on the mast (Fig. 1). Once the Emergency Stop button has been operated, it must be reset by turning the red cap until it pops out. Now the *Tenor* can be operated again.

Power on / Reset button (green): Located on the top control panel (Fig. 1). Press this button to turn on power to the *Tenor*. Also used to reset if the automatic overload fuse has operated (indicated by the button projecting outwards slightly). If the fuse has operated and, once reset, operates again, withdraw the lifter from use and contact Arjo or their appointed distributor.

Power off button (red): Located on the top control panel (Fig. 1). Press this button to turn off power to the *Tenor*.

Automatic cut out: If the lift is accidentally overloaded, trying to lift a resident heavier than permitted, an automatic 'cut out' operates to prevent the lift lifting a load in excess of one and a half a times the maximum allowed load. The lift motion will stop automatically.

System failure lower override: In case of control handset / dual switch malfunctioning, with a resident still supported by the sling, the lowering process can be continued using the system failure lower override, situated on the lift actuator tube (See Figs. 1 & 3).

To use this function, turn the red ring on top of the motor / actuator of the *Tenor* clockwise, using the resident's own weight to enable the mast to slowly lower. To stop lowering, simply stop turning the ring. Only use this function in the event of normal control failure. Do not use it for normal function lowering.

Product description

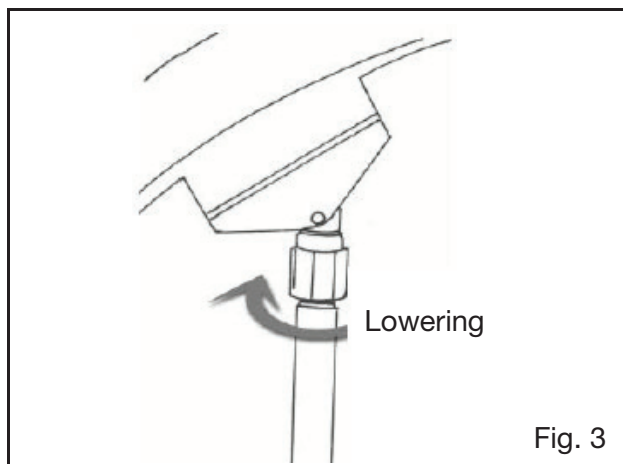

WARNING

Before operating the “System failure lower override” to lower a resident, always ensure that a chair or suitable support is underneath ready to accept the resident.

Automatic stop function: Great care should be taken not to lower the jib and / or spreader bar onto the resident or any obstruction, particularly when the resident is standing up and weight bearing. If this should happen, the motor will continue to run but downward movement will be blocked by the obstruction. If this occurs, release pressure from the “lower” button immediately and operate the “raise” button until the equipment is clear. Then remove the obstruction.

OverHeat Protection: The buzzer will beep twice every 15s and “OverHeat” will display on the LCD. This happens when the caregiver exceeds the duty cycle for the lift actuator (2 min / 18 min) When it starts beeping, lifting and lowering is still possible. This function protects actuator against damage.

Battery discharge indicator: There is a small battery symbol on the bottom of the LCD. The battery symbol shows the level of battery charge. (See Fig. 1 and also the ‘Battery Charging’ section for complete description).

Chassis castor brakes: The chassis rear castors have brakes which can be foot operated (See Fig. 4).

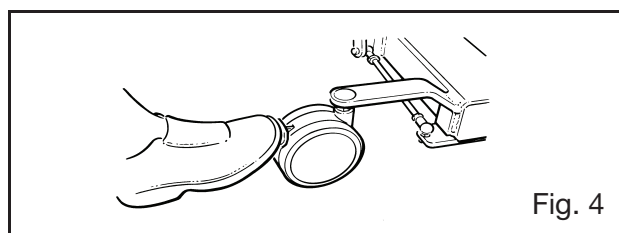

Powered adjustable width chassis legs: The mobile chassis legs can be opened to avoid obstructions e.g. chair legs. This can be done by operating the hand control, using only one hand and having the other free to hold onto the lift or care for the resident. Use the lower button to close the chassis legs and the upper one to open them (See Fig. 2).

Numerous positions can be obtained between fully opened and fully closed.

Transportation should be done with the chassis legs closed, it will be easier to push the lifter through doorways, etc.

When opening the chassis legs, the rear castors will close inwards.



WARNING

When opening or closing the legs on a powered chassis, care must be taken not to allow anyone to stand in the way of the moving chassis legs.

Hour/Cycle Meter: On the top of the LCD display it shows the total duration of the lift and lowering operation (in hours - see item 17B, Fig. 1). The LCD can also show the number of cycles by simultaneously pressing the “raise” and “lower” button. This is primarily intended to help the caregiver calculate maintenance intervals.

Scale (optional): To use the scale, if available, refer to the *Scale IFU*.

Using your Tenor

CHECKLIST BEFORE USE

For a list of what to check before use, please read the “Preventive Maintenance Schedule” section of this document.

PREPARATION

Unpack the battery supplied with the lift.



CAUTION

A battery that is charged for the first time, or after a long storage period, must be charged until the charger indicates full charge (See “Battery charger IFU 001-24257”).

When the battery pack is fully charged, disconnect the mains power, then remove the pack from the charger and insert it fully into the *Tenor* battery position, located at the rear of the mast (See Fig. 1). Electrical connection is made automatically.

Before approaching the resident



WARNING

Never leave the resident unattended.

The caregiver should always tell the resident what he / she is going to do and have the correct sling size ready. Where possible, always approach the resident from the front.

To ensure maximum resident comfort, do not allow the resident to hold onto the spreader bar.

If required, the chassis legs may be opened to go around a chair, wheelchair or to avoid bed legs or any other obstruction.

To lift a resident from a chair

Hold the sling up with the leg sections pointing downwards (See Fig. 5), to identify the orientation of the sling.

Before using a sling, first read the ‘Guidelines on the use of your sling’ and the sling label, which are delivered with the sling.

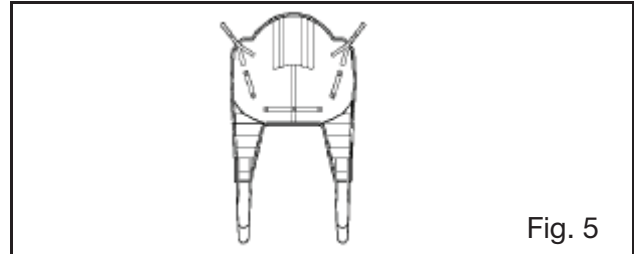

Fig. 5

Place the sling around the resident so that the bottom of the back support area reaches the bottom of the resident’s spine (it is not necessary to pull the sling under the resident). Ensure the head support area is behind the head (See Fig. 5).

Pull each leg section under each thigh so that they appear on the inside of the thighs (See Fig. 6).

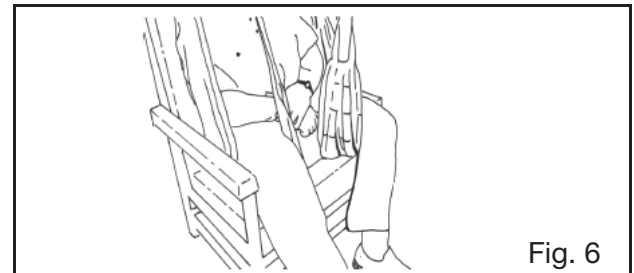

Fig. 6

Ensure the sling is not folded or twisted under the resident (See Fig. 6).

Move the *Tenor* towards the resident, ensure the widest side of the spreader bar is facing towards the resident and is at, or just below, shoulder level (See Fig. 7).

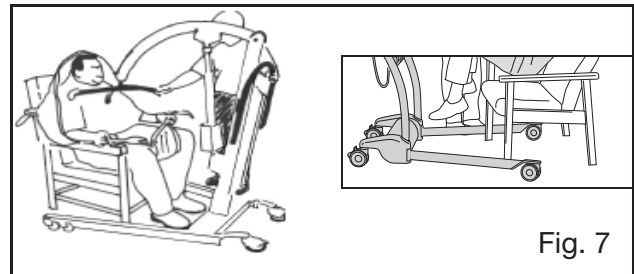

Fig. 7

Using your Tenor

Ensure that the *Tenor* is close enough to be able to attach the shoulder loops of the sling to the spreader bar. To accomplish this, you may have to put the resident's feet on or over the chassis.

If the slings supplied have more than one loop attachment position, attach whichever loop seems appropriate to the size of the resident.

Once the *Tenor* is in position, attach the shoulder strap loops to the hooks on the spreader bar nearest to the resident (See Figs. 8 & 9).

The wider hook up points are for the shoulder sling loops and the narrower hook up points are for the leg sling loops (See Fig. 9).

If necessary, carefully lower the spreader bar a little bit using the control handset to enable the connection of the sling leg section loops, being careful not to lower it onto the resident.

The leg section loops should not be crossed over or twisted. Instead, the left leg section loop should be connected to the exact side hook above the leg being lifted (See Figs. 6 & 8).



WARNING

When lifting or lowering the resident, ensure that no part of the resident's body can be caught between the lift's moving parts.

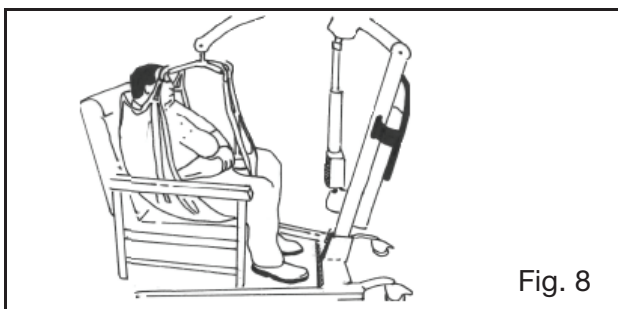

Fig. 8



WARNING

Always check that all sling attachment loops are completely underneath and away from the safety latch on the hanger bar, before and during the commencement of the lifting cycle, in tension as the resident's weight is gradually taken up (See Figs. 8 & 9).

Raise the resident with the control handset, just high enough to move the resident clear of the seat, ensure their feet are clear of the floor.



Fig. 9

Before transportation, turn the resident to face the caregiver and lower the individual to approximately normal chair height. This gives confidence and dignity and also improves the *Tenor* mobility.

To return resident back to a chair

When returning to a chair, make sure the lift legs are positioned around the legs/wheels of the chair. To position the resident over the chair, use the lift handles, do NOT pull the sling. The resident suspended in sling should always remain in the centre of gravity. Use the hand control to lower the resident. (see Fig. 10).

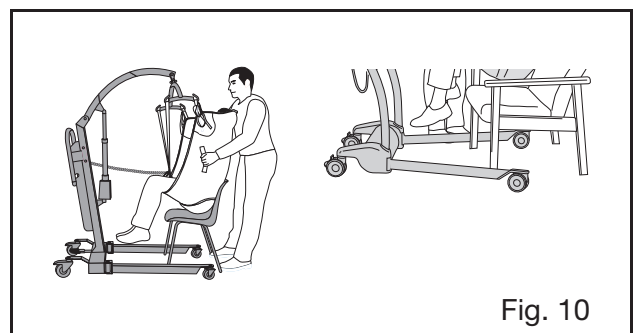

Fig. 10

Using your Tenor

To lift a resident from a bed



WARNING

When lowering the resident back into a chair or when transferring from bed to chair, position the resident in such a way that he / she is fully supported by the chair when he / she is lowered.

Before lifting a person from a bed, ensure there is sufficient clearance underneath the bed to accommodate the *Tenor* chassis legs. Adjust width of chassis legs if necessary.

Position the resident onto the sling by rolling the resident towards you, then folding the sling in half and placing it behind the resident's back, so that the bottom edge of sling is aligned with bottom of the resident's spine (See Figs. 11, 12 & 13). Position the sling carefully so that when rolled back, the resident will lie centrally on the sling. Check that the head support area of the sling is in position.

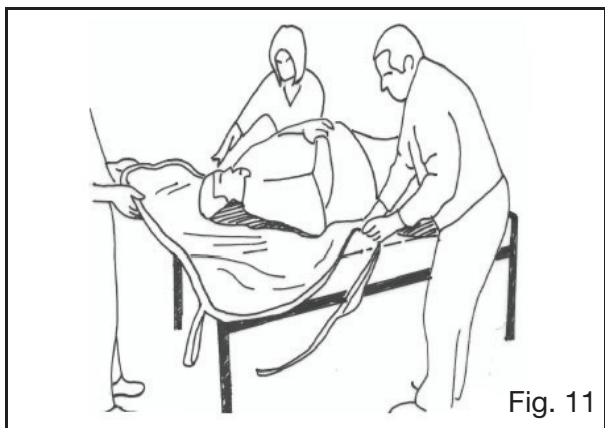

Fig. 11

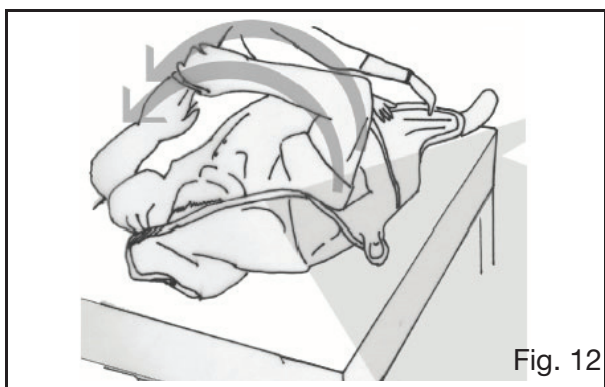

Fig. 12

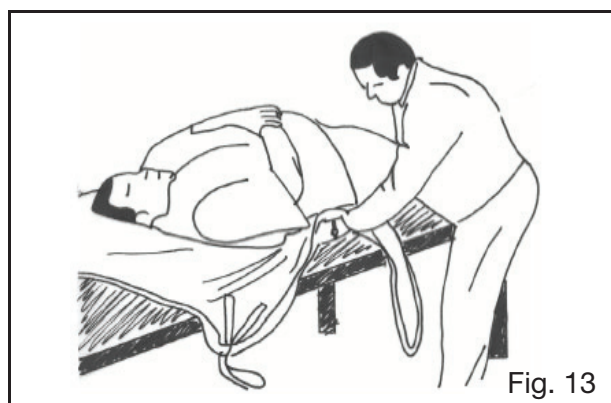

Fig. 13

When rolling the resident back onto the sling, roll them slightly in the opposite direction so that the folded part of the sling can be brought out.

Alternatively, the resident can be brought into a sitting posture. Then position the sling as detailed in the section "To lift a resident from a chair".

Using the adjustable width chassis, it is possible to make adjustments to chassis leg widths to assist manoeuvrability around obstructions, for example, bed legs.

Make sure the lift is positioned perpendicular to the bed. (see Fig. 14)

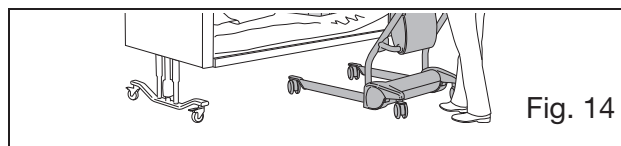

Fig. 14

Approach the bed with the open side of the *Tenor* spreader bar towards the resident's head.

Position the *Tenor* so that the spreader bar is just above and centrally situated over the resident.

Carefully lower the spreader bar until the shoulder attachment loops can be connected to the hooks nearest to the resident's head.

Using your Tenor

Slide the leg sections of the sling under the resident's thighs and connect each loop on the side hook above each leg.

To make the lift more comfortable for the resident, it is recommended to lift the head end of the bed to semi-reclined position before commencing the lifting of the resident.

When correctly connected, operate the control handset to raise the resident from the bed. At all times when lifting and lowering, it is advisable to stay at the side of the resident to ensure they are in a comfortable position. This is also reassuring to the resident.

The resident suspended in sling should always remain in the centre of gravity.



WARNING

Always check that the sling attachment loops are fully in position before and during the commencement of the lifting cycle, and in tension as the resident's weight is gradually taken up.

After lifting the resident, adjust to a comfortable height for transfer. The specially designed sling, together with its integral head support, enables one person to carry out a complete lifting function without additional help.

To return resident to a bed

If returning the resident to a bed, move into the desired position above the bed and then lower using the control handset. When returning to a bed, make sure the lift is positioned perpendicular to the bed (see Fig. 15).

To position the resident over the bed, use the lift handles, do NOT pull the sling. The resident suspended in sling should always remain in the centre of gravity. Use the hand control to lower the resident.

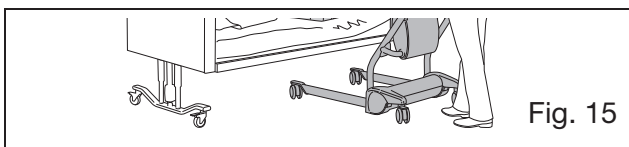

Only when the resident's body weight is fully supported by the bed, may the sling connection loops be detached and while still in sitting position, detach the sling from the hooks before reclining the resident to the bed.

Move the *Tenor* away before removing the sling from under the resident.

If transferring the resident to a chair, refer to the section "To return resident back to the chair".

Using your Tenor

To lift a resident from the floor

Put the sling around the resident as before, by using the rolling or seated position method. Depending on circumstances, space and / or position of the resident etc., open the chassis legs if necessary and carefully approach the resident with the front of the lift. Now lift the resident's legs over the chassis as shown in Figure 13, should the situation require it.

The resident's head and shoulders should be raised on pillows for comfort. This will also make it easier to attach the shoulder position attachment loops (See Fig. 16).

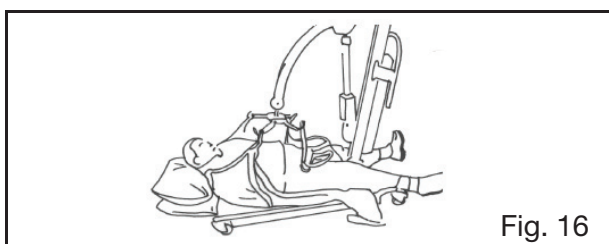

Attach the shoulder strap attachment loops. It will probably be easier to attach the longest loops.

Some caregivers prefer to use a larger sling when lifting a resident from the floor.

Bring each leg section of the sling under the resident's thighs and attach each leg strap loop to the side hook above each leg (See Fig. 17).

Once securely connected, raise the resident carefully, staying in close proximity of the resident's legs at this stage of the lift to guide his / her legs safely over the lift until clear. Once raised from the floor, ensure the resident's legs are clear of the chassis before continuing to lift.

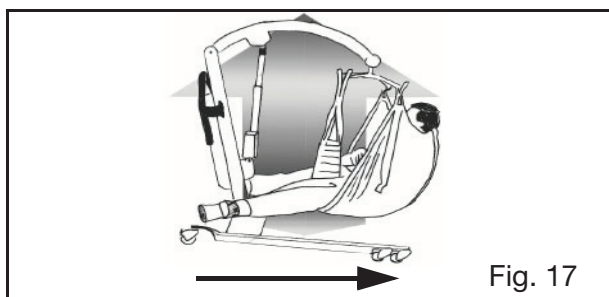

Always move the *Tenor* in the direction shown in Fig. 17.

Raise the resident to a suitable height for transport in a semi-recumbent position.



WARNING

Before and during the commencement of the lifting cycle, always check that all the sling attachment loops are fully in position and in tension as the resident's weight is gradually taken up and that the sling loops are underneath and away from the safety latch on the hanger bar.

If the leg sections of the sling tend to be fairly high in the crotch area, make adjustments for added comfort. The resident should be positioned in a chair or placed onto a bed in order to do this.

If the resident is prone to extensor spasm, he / she may be lifted with the *Tenor*, but special attention should be paid to supporting the legs during lifting.

Staff assessment should be made to determine if a spastic or combative resident requires an additional caregiver to assist.

Transportation of a resident is possible with the chassis legs open or closed, but manoeuvrability will be easier, especially through doorways, with the chassis legs closed. The resident should be positioned facing the caregiver and at a dignified height.

Apply the brakes on an incline.

Battery charging



WARNING

Only use the Arjo battery that is supplied with the *Tenor*.

Only use Arjo components that have been specifically designed for the purpose when charging batteries.

The *Tenor* incorporates a battery discharge indicator, situated on the rear of the battery / electronics compartment (See Battery discharge indicator in chapter Labels, item 5).



WARNING

No smoking or naked flames in battery vicinity.

Do not place batteries near, or dispose of, in a fire.

Do not short circuit a battery.

Do not store batteries at temperatures in excess of 60°C (140°F).

Do not crush, puncture, open, dismantle, or otherwise mechanically interfere with batteries.



WARNING

Should the battery casing become cracked and electrolyte come into contact with skin or clothing, wash immediately with water.

If the electrolyte contacts the eye, wash immediately with copious amounts of water and seek medical attention.

When disposing of batteries, contact the appropriate local authorities for advice.

The abbreviation "Pb" shown next to the recycling and trash bin symbols on the battery pack label is the element symbol for lead and indicates that the battery contains lead and therefore should not be disposed of in the normal manner but must be recycled.

Battery charging

It is recommended that the battery is removed from the lifter and recharged when the battery discharge indicator displays 3 filled segments of battery charge and the buzzer beeps once every 10s. However, at this point lifting is still possible until the display shows one filled segment and the buzzer beeps continuously.

Best practice is to charge batteries at each shift to maximize battery life. Avoid totally discharging the battery, this will prolong battery life.

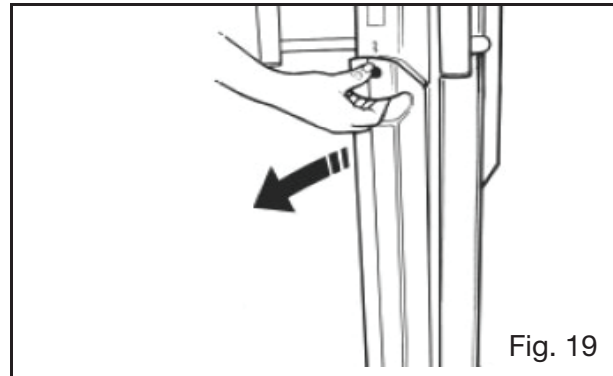

CAUTION

A battery that is charged for the first time or after a long storage period must be charged until the charger indicates full charge.

A discharged battery must be left to charge until the charger indicates full charge.

To ensure the *Tenor* is always ready for use, it is recommended that a freshly charged battery pack is always available. This is achieved by having additional battery packs available and keeping one on charge while the other is in use.

The battery life is variable (2-5 years) and mainly depends on proper charging practices. To extend the battery life, the batteries must be charged at regular interval until the charger indicates full charge.

It may be considered good protocol to have a freshly charged battery pack ready for the start of every work shift.

Place the battery pack on charge as follows:

When the battery discharge indicator displays 3 filled segments, complete your lift cycle. Then take the lifter to a convenient location and remove the battery pack by holding the grip handle on the top and lift clear (See Fig. 19). Take the battery to the battery charger unit, ensure the battery is positioned securely (See “Battery charger IFU 001-24257).



WARNING

Hold the pack firmly to ensure it does not drop and become damaged or cause personal injury.

When the battery pack is fully charged, disconnect the mains power, remove the battery pack from the charger and insert it back into the *Tenor* battery compartment.

Ensure that the green Power On / Reset button (Fig. 1) is pressed in.

The Tenor is now ready for use.



CAUTION

After use, turn off the *Tenor* by pressing the red Power off button (Fig. 1) to reduce power consumption.

Care of your TENOR

How often the following actions are taken, depends on how often the equipment is used.

Unless otherwise stated, before each and every use follow the cleaning, care and inspection procedures described in this section.



WARNING

It is recommended that resident lifters, equipment, accessories and slings supplied by Arjo are regularly cleaned and / or disinfected between each resident use if necessary, or daily as a minimum. If the slings, lifters and equipment need cleaning or are suspected of being contaminated, follow the cleaning and / or disinfection procedures below, before re-using the equipment. This is especially important when using the same equipment for another resident to minimize the risk of cross infection.

For cleaning your lifter, equipment and accessories wipe down with a damp cloth using warm water to which a mild detergent has been added.

For disinfection of contaminated lifters, equipment and accessories, use the preferred method of wiping the product completely with “hard surface disinfectant wipes” that are supplied impregnated with a mild detergent.

A rubbing action will be necessary when using the wipes to promote effective disinfection of the surfaces.



WARNING

Cleaning and disinfection products must be used in accordance with the manufacturer's instructions and suitable eye, hand and clothing protection must be worn at all times when handling disinfectants.

Servicing Advice



CAUTION

Do not use the product in wet areas, as this could cause problems with electrical components or internal corrosion.

If a hot air dryer is used to dry the lifter, the temperature must not exceed 90°C (194°F)

Do not use petroleum based solvents or similar. This may damage plastic parts.



WARNING

Arjo recommends that the *Tenor* is maintained at regular intervals. See Arjo Preventive Maintenance Schedule.

Spare parts, if required, are available from Arjo or their approved distributors. Parts list and circuit diagrams are available from Arjo or their approved distributors upon request.

Special tools are required for certain component replacement.

UK LIFTERS ONLY: Important new legislation came into force on 5th December 1998, which has an impact on the schedule of service for your resident lifter(s), variable height baths and other raising and lowering equipment. The Lifting Operations and Lifting Equipment Regulations (LOLER) 1998 and the Provision and Use of Work Equipment Regulations (PUWER 98) must be satisfied by the duty holder. A scheme of six monthly through examinations has been devised to comply with the law and details can be obtained from Arjo Service UK.

The simplest, safest and most effective way to maintain your product in good working order, is to have it methodically and professionally serviced by an Arjo approved engineer using Arjo approved spare parts

Care of your TENOR

For information on service and maintenance contracts, please contact your local Arjo distributor.

Slings



CAUTION

The sling should be checked before and after using with each resident and if necessary, washed according to the instructions on the sling. Also refer to the sling instruction sheet.



WARNING

When using your sling, always read “the Guidelines on the use of your sling” that are delivered with the sling.

Environmental Advice

When disposing of any items associated with the equipment, contact the appropriate local authority for advice.

With regard to laundering, the sling should not be classified as linen, but as an accessory to a resident transfer lifter and therefore classified as a medical device. Slings should be cleaned and disinfected only in strict accordance with the manufacturer’s instructions.



WARNING

Mechanical pressure should be avoided during the washing and drying procedure e.g. rolling and pressing, as these can damage parts vital to the safe and comfortable operation of the sling.



CAUTION

Washing and drying procedures must not exceed 90°C (194°F). Wash using normal detergents, do not iron. Also refer to the sling instruction sheet.

It is essential that resident lifters, equipment, accessories and slings supplied by Arjo are regularly cleaned and/or disinfected between each resident use if necessary, or daily as a minimum. If the slings, lifters and equipment need cleaning or are suspected of being contaminated, follow the cleaning and/or disinfection procedures below, before re-using the equipment. This is especially important when using the same equipment for another resident to minimize the risk of cross infection.

Labels

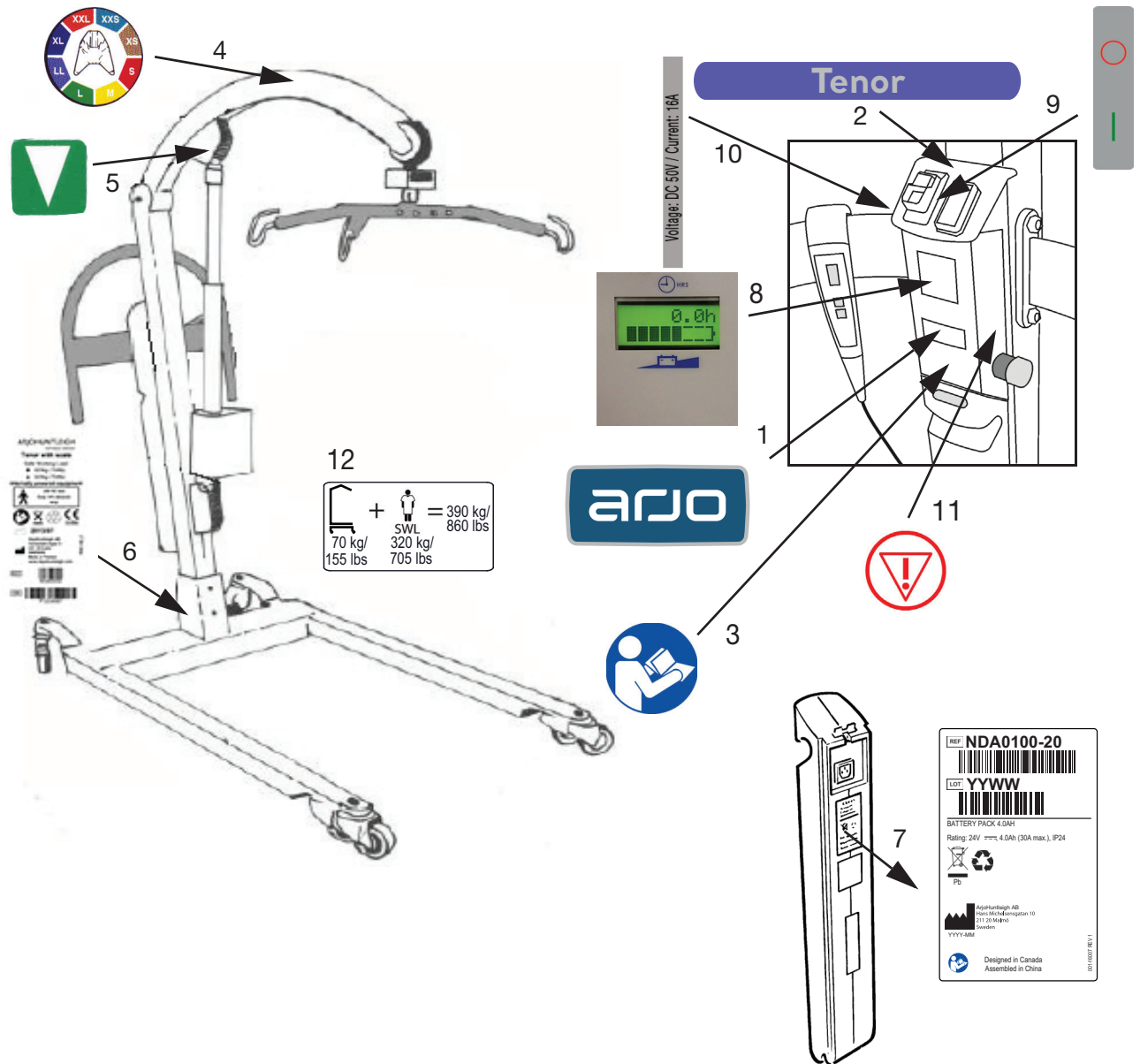

Key to labels:

- | | |
|---|---|
| 1. Arjo logo | 7. Battery instruction / Recycling information |
| 2. Product name | 8. Hour/Cycle meter / Battery discharge indicator |
| 3. Attention - Read operating instructions before use | 9. On / off label |
| 4. Sling size guide | 10. Voltage / current reading |
| 5. System failure lower override identification | 11. Emergency stop button label |
| 6. Safe Working Load and Serial number / chassis ref. | 12. Maximum total weight of lift (lift + patient) |

Technical specification

Component Weights

	kg	lbs
Tenor complete with scale, battery	70	155
Tenor complete without scale	69.1	152.3
Maximum total weight of lift (lift + patient)	390	860

In normal use, the *Tenor* can be broken up into two parts:

Battery pack	3.8	8.4
Tenor (without Battery pack)	65.3	144
Tenor with scale (without Battery pack)	66.4	146.4

The *Tenor* is not intended to be broken up into more than these parts.

Maximum Lifting Capacities (Safe Working Load - SWL)

Tenor	320	705
All slings - Please verify with the SWL on the sling label		

Electrical

Battery type	Rechargeable - sealed lead acid
Battery part number	NDA0100-20
Battery capacity	4Ah
Lift - Protection class - Ingress of fluid	IPX4
Lift - Protection class - Electrical shock protection	Internally powered equipment
Lift nominal voltage	24V
Fuse - Overload	16A (thermal cutout)
Fuse - PCBA	20A (time delay)
Operating forces - Handset	2.5N

See Battery Charger IFU 001-24257 for technical specifications

Medical Equipment – type  protection against electrical shock in accordance with IEC 60601-1.

Certified by TUV for standard IEC 60601-1:2012(ed.3.1) and EN ISO10535:2006.

	Duty cycle	Max volts	Max amps
Lift actuator	10% – 1 min / 9 min	24 V	10 A
“V” Chassis actuator	10% – 2 min / 18 min	24 V	2 x 2,3 A

Mode of operation: intermittent

Environment

Air humidity	80% @ 20°C (68°F)
Usage temperature range (ambient)	+ 5°C (41°F) to + 35°C (95°F)
Optimum usage temperature (ambient)	+ 20°C (68°F) to + 25°C (77°F)
Storage and transportation temp (ambient)	- 10° C (14°F) to + 45°C (113°F)

Technical specification

Maximum sound power level

In accordance with ISO3746

Unloaded 67 dBA

Fully loaded 71 dBA

Product is a medical device, risk class 1, withing the meaning of the Medical Device Directive 93/42/EEC

Product was designed and manufactured to fulfil the essential requirements from Annex 1 of the Medical Device Directive 93/42/EEC

Hoist Dimensions

(drawing on page 23)

A. Max. external length: 1485 mm / 58.5"

B. Max. internal length: 1030 mm / 40.6"

C. Max. external width: 1240 mm / 48.8"

D. Max. internal width: 1135 mm / 44.7"

E. Min. external width: 740 mm / 29.1"

F. Min. internal width: 620 mm / 24.4"

G. Height of C.S.P. at max. hoisting reach: 1405 mm / 55.3"

H. Min. distance wall to C.S.P. at max. reach (legs spread): 335 mm / 13.2"

I. Min. height of C.S.P.: 800 mm / 31.5"

J. Min. distance wall to C.S.P. at min. height (legs spread): 530 mm / 20.9"

K. Max. height of C.S.P.: 2025 mm / 79.7"

L. Min. distance wall to C.S.P. at max. height (legs spread): 545 mm / 21.5"

M. Hoisting range: 1225 mm / 48.2"

N. Min. clearance 20 mm / 0.8"

O. Max. height: 102 mm / 4"

P. Turning radius: 1650 mm / 65"

Note: 'C.S.P.' stands for 'Central Suspension Point': a reference point on the lift used for measurements. On the Tenor, the C.S.P. is the clips attachment point closest to the resident at the start of the lifting cycle.

Technical specifications may be revised and changed without prior notice.

Technical specification

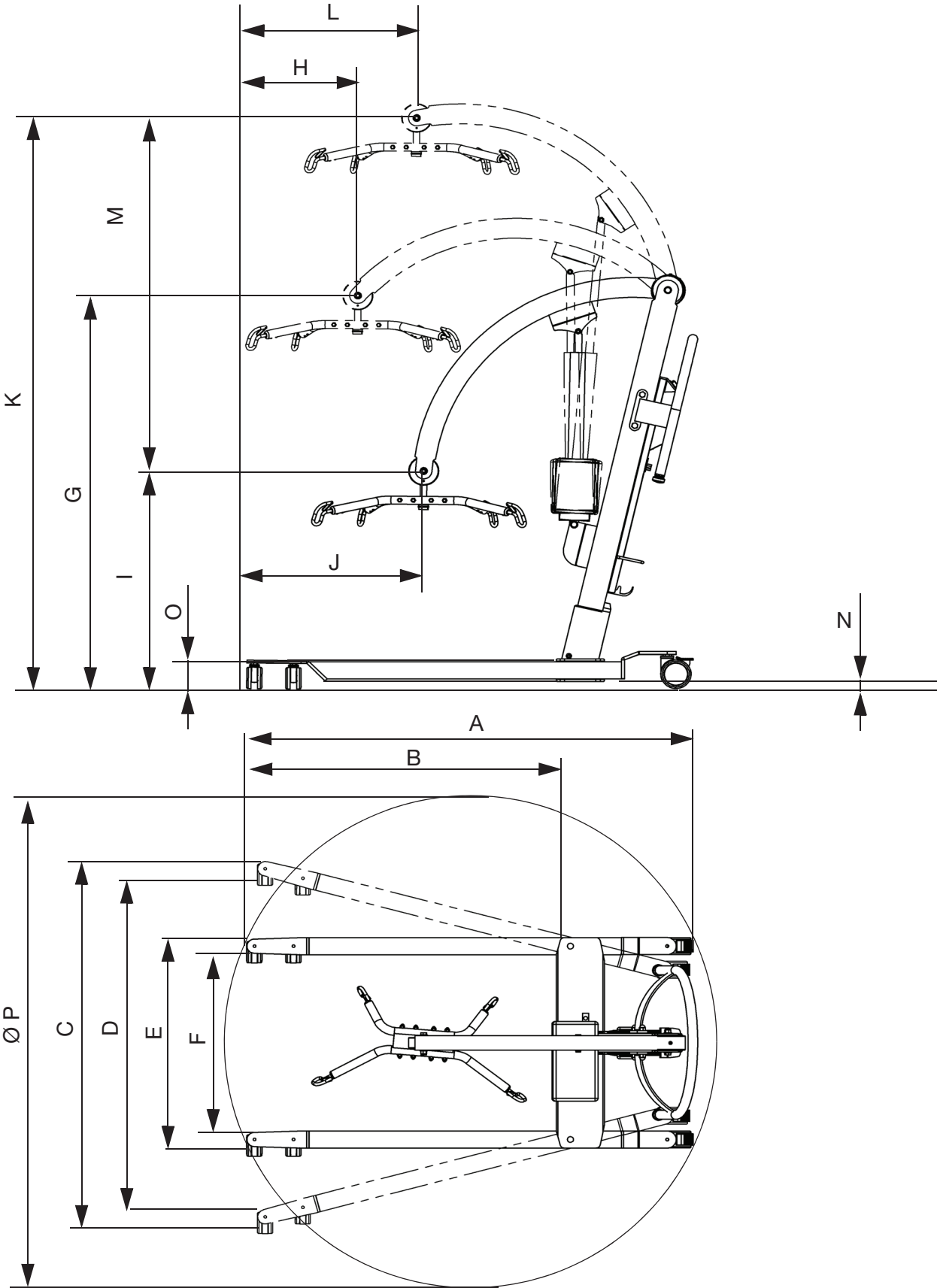

Troubleshooting / Problem Solving

Problem description:

The *Tenor* is (brand new and) not functioning at all.

Probable cause:

Power Off button (red) is still engaged.

Solution:

Please press the Power on / Reset button (green).

Problem description:

The *Tenor* is raising and lowering slower than normal.

Probable cause:

Low battery power level.

Solution:

Please check LCD battery discharge indicator the *Tenor*. This should indicate the power level of the battery. In case of doubt, change the battery on the lift with a fully charged battery and compare performance. In case of low battery power level, please charge the battery and use a fully charged one to continue using the *Tenor*.

Problem description:

The *Tenor* is not raising or lowering, and/or the chassis can not be opened or closed.

Probable cause:

Hand control is damaged.

Solution:

Please try operating the lift with the Dual Up/ Down Control situated on the mast of the *Tenor*. Should the lift fully function when these controls are used, and should the lift not fully function when using the hand control, the hand control should be replaced.

Problem description:

As above, the *Tenor* does not function properly, not with the hand control, neither with the Dual Up-Down Control switches.

Probable cause:

Electronics PCB is malfunctioning or actuator (on lifting arms or in chassis) is malfunctioning

Solution:

Please contact your Arjo dealer or Arjo approved service engineer.

Troubleshooting / Problem Solving

Problem description:

While pressing the 'Chassis legs open' button, the *Tenor* makes a noise, "overload" displays on the LCD and the buzzer beeps continuously but the chassis legs are not opening.

Probable cause:

An obstruction is blocking the chassis legs.

Solution:

Please remove the obstruction and check thoroughly for damage before continuing the lifting cycle. When in doubt, use the System Failure Lowering Override to put the resident back into a safe seated position before removing the *Tenor* and placing it out of order till it has been inspected and approved for safe working by an Arjo approved engineer.

Problem description:

The functions on the *Tenor* are not working properly

Probable cause:

Malfunction of EMC of the hoist making the hoist vulnerable for radiation influences of other machinery

Solution

Operate the *Tenor* in an environment without influence of radiation.

Problem description:

Unexpected movement of the hoist

Probable cause:

Two control buttons pressed simultaneously; faulty hand control, push buttons or electronics

Solution

Release both control buttons. If this doesn't work, press the red Emergency Stop button and remove the battery. Use the System Failure Lowering Override to put the resident back into a safe seated position before removing the *Tenor* and placing it out of order till it has been inspected and approved for safe working by an Arjo approved engineer.

Problem description:

"OverHeat" displays and the buzzer beeps twice every 15s.

Probable cause:

Operator excess the actuator duty cycle (2 min ON and 18 min OFF)

Solution

Finish operating cycle and wait 18 min. The operation prevents the actuator against damage.

Preventive Maintenance Schedule

The *Tenor* is subject to wear and tear, and the following actions must be performed when specified to ensure that the product remains within its original manufacturing specification.

	<p>WARNING</p> <p>The points on this checklist are the minimum the manufacturer recommends. In some cases due to heavy use of the product and exposure to aggressive environment, more frequent inspections shall be carried out. Continuing to use this product without conducting regular inspections or when a fault is found will seriously compromise the user and residents' safety. Local regulations and standards may be higher than the manufacturers. Preventive maintenance specified in this manual can prevent accidents.</p> <p>The parts which are entitled 'Checks to be performed by Qualified Arjo personnel' have to be carried out by qualified personnel, using the correct tools and knowledge of procedures. Failure to meet these requirements could result in personal injuries and / or unsafe product.</p>
---	---

Note: Product cannot be maintained and serviced while in use with the patient.

Preventive Maintenance Schedule

Action/Check	Before each use	Every day	Every Week	Every 6 months	Every 12 months
CAREGIVER OBLIGATIONS					
ARJO SLINGS					
Examine the slings, their straps and attachment loops. If any part of the sling or its straps is frayed or any one of the loops is damaged, the sling must be withdrawn from use immediately and replaced with a new sling.	X				
Where necessary, after resident use, carry out decontamination of the sling in accordance with Arjo and local decontamination regulations	X				
Read the Guidelines on the use of your sling.	X				
ARJO BATTERY CHARGER					
Visually examine the battery charger for loose connectors, cut wires and damage to the casing. Do not use if found loose, cut or damaged in any way	X				
ARJO TENOR					
Make sure the battery is charged before use. If not adequately charged, replace with a fully charged battery.	X				
When necessary, after each resident use, carry out decontamination of the Arjo <i>Tenor</i> in accordance with Arjo Operating Instructions and local regulations.	X				
Make sure the battery pack is in a good state of charge. Charge the battery at the end of each working shift until the charger indicates full charge.		X			
The lifter is fitted with a warning device. When the battery discharge indicator reaches the red flashing light, the battery must be charged as soon as possible		X			
Make sure all castors rotate freely and the two rear brakes lock.		X			
Make sure the castor-mounting pin is tight on the chassis and chassis legs and the castor tread is not damaged. Be sure to remove any fluff, hair or debris from the wheels to ensure their proper functioning.		X			
Check that all external fittings are secure and that all screws and nuts are tight.		X			

Preventive Maintenance Schedule

Examine all exposed parts, especially where there is personal contact with the resident's body. Make sure no cracks or sharp edges have developed that could cause resident or user injury or have become unhygienic. Replace or clean/disinfect them where necessary.		X			
Make sure all instruction labels are firmly attached and readable.		X			
Make sure that the sling attachment is visually inspected. Any component found frayed or damaged, must be withdrawn from service immediately and replaced.		X			
For longevity, charge batteries until the charger indicates full charge.			X		
Operate the lift through its full range. Make sure the lift can operate in a normal and smooth manner.			X		
Open and close the chassis legs and check for full travel and smooth movement.			X		
Examine the condition of the handset and its cable. Withdraw from service immediately and replace with new cable and handset assembly if damaged. Examine and ensure all external fittings are secure and all screws, bolts and nuts are tight.			X		
Examine the integrity of the loop lock assemblies on the hangar bar.			X		
CHECKS TO BE PERFORMED BY QUALIFIED ARJO PERSONNEL					
Perform the weekly PMS checks				X	
Test the Automatic Stop Function as follows. Raise or lower the lift arm until the spreader bar reaches eye height. Now hold the lift arm with your hand while using the remote control handset to lower the lift arm. The actuator will continue to run, but the lift arm is held up by your hand. Release the handset button and slowly lower the lift arm you are holding until you feel it is supported by the actuator.				X	
Test the Emergency Stop Feature by operating the cable remote control handset to raise or lower the Lift arm. While operating, press the emergency stop button. Powered movement must stop immediately. Repeat the test, this time operating the opening and the closing of the chassis legs.				X	
Examine the sling attachment points on the lift arm. If found damaged, replace the lift arm.				X	
Examine the clip assembly for damage or deterioration. Replace if necessary.				X	
Perform the 6 monthly PMS checks					X
Examine the actuator.					X
Examine the clip assembly for damage or deterioration. Replace if necessary.					X
Examine the Foot bracket condition.					X
Make sure the chassis legs are square to the chassis member.					X
Do a torque tightening check of the following: (a) Castors to the chassis and legs 4 off - 25 Nm (18lb ft) (b) Chassis leg pivot bolts 2 off - 47 Nm (35 lb ft)					X

Electromagnetic Compatibility (EMC)

Product has been tested for compliance with current regulatory standards regarding its capacity to block EMI (electromagnetic interference) from external sources.

Some procedures can help reduce electromagnetic interferences:

- Use only ArjoHuntleigh cables and spare parts to avoid increased emissions or decreased immunity which can compromise the correct functioning of the equipment.
- Ensure that other devices in patient-monitoring and/or life-support areas comply to accepted emissions standards.

	<p>WARNING</p> <p>Wireless communications equipment such as wireless computer network devices, mobile phones, cordless telephones and their base stations, walkie-talkies, etc. can affect this equipment and should be kept at least 1.5 m away from the equipment.</p>
---	---

Intended Environment: Professional Healthcare Facility Environment

Exceptions: HF Surgical Equipment and the RF Shielded room of an ME SYSTEM for magnetic resonance imaging

	<p>WARNING</p> <p>Use of this equipment adjacent to or stacked with other equipment should be avoided because it could result in improper operation. If such use is necessary, this equipment and the other equipment should be observed to verify that they are operating normally.</p>
---	---

Guidance and manufacturer's declaration: electromagnetic emissions (EMI)		
Emissions test	Compliance	Guidance
RF emissions CISPR11	Group 1	This equipment uses RF energy only for its internal functions. Therefore its RF emissions are very low and are not likely to cause any interference in nearby electronic equipment.
RF emissions CISPR 11	Class B	This equipment is suitable for use in all establishments, including domestic establishments and those directly connected to the public low voltage power supply network that supplies buildings used for domestic purposes.

Guidance and manufacturer's declaration: electromagnetic immunity			
Immunity test	IEC 60601-1-2 test level	Compliance level	Electromagnetic environment - guidance
Electrostatic discharge (ESD) EN 61000-4-2	±2kV, ±4kV, ±8kV, ±15kV air ±8kV contact	±2kV, ±4kV, ±8kV, ±15kV air ±8kV contact	Floors should be wood, concrete or ceramic tile. If floors are covered with synthetic material the relative humidity level should be at least 30%.
Conducted disturbances induced by RF fields EN 61000-4-6	3V in 0,15 MHz to 80 MHz 6V in ISM and amateur radio bands between 0,15 MHz and 80 MHz 80% AM at 1 kHz	3V in 0,15 MHz to 80 MHz 6V in ISM and amateur radio bands between 0,15 MHz and 80 MHz 80% AM at 1 kHz	Portable and mobile RF communications equipment should be used no closer to any part of the product, including cables, than 1.0 m, if the transmitter's output power rating exceeds 1W ^a Field strengths from fixed RF transmitters, as determined by an electromagnetic site survey, should be less than the compliance level in each frequency range ^b
Radiated RF electromagnetic field EN 61000-4-3	Professional Healthcare environment 3 V/m 80 MHz to 2,7 GHz 80% AM at 1 kHz	Professional Healthcare environment 3 V/m 80 MHz to 2,7 GHz 80% AM at 1 kHz	
Proximity fields from RF wireless communications equipment EN 61000-4-3	385 MHz - 27 V/m 450 MHz - 28 V/m 710, 745, 780 MHz - 9V/m 810, 870, 930 MHz - 28 V/m 1720, 1845, 1970, 2450 MHz- 28 V/m 5240,5500, 5785 MHz - 9V/m	385 MHz - 27 V/m 450 MHz - 28 V/m 710, 745, 780 MHz - 9V/m 810, 870, 930 MHz - 28 V/m 1720, 1845, 1970, 2450 MHz - 28 V/m 5240,5500, 5785 MHz - 9V/m	Interference may occur in the vicinity of equipment marked with this symbol: 
Electrical fast transient/burst EN 61000-4-4	±1kV SIP/SOP ports 100 kHz repetition frequency	±1kV SIP/SOP ports 100 kHz repetition frequency	
Power frequency Magnetic field EN 61000-4-8	30 A/m 50 Hz or 60 Hz	30 A/m 50 Hz	Power frequency magnetic fields should be at levels characteristic of a typical location in a typical commercial or hospital environment.
<p>^a Field strengths from fixed transmitters, such as base stations for radio (cellular/cordless) telephones and land mobile radios, amateur radio, AM and FM radio broadcast and TV broadcast cannot be predicted theoretically with accuracy. To assess the electromagnetic environment due to fixed RF transmitters, an electromagnetic site survey should be considered. If the measured field strength in the location in which the product is used exceeds the applicable RF compliance level above, the product should be observed to verify normal operation. If abnormal performance is observed, additional measures may be necessary.</p> <p>^b Over the frequency range 150 kHz to 80 MHz, field strengths should be less than 1 V/m.</p>			

AUSTRALIA

Arjo Australia Pty Ltd
78, Forsyth Street
O'Connor
AU-6163 Western Australia
Tel: +61 89337 4111
Free: +1 800 072 040
Fax: + 61 89337 9077

BELGIQUE / BELGIË

Arjo NV/SA
Evenbroekveld 16
BE-9420 ERPE-MERE
Tél/Tel: +32 (0) 53 60 73 80
Fax: +32 (0) 53 60 73 81
E-mail: info.belgium@arjo.be

BRASIL

Arjo Brazil
Maquet do Brasil
Rua Tenente Alberto Spicciati, 200
Barra Funda, 01140-130
SÃO PAULO, SP - BRASIL
Fone: +55 (11) 2608-7400
Fax: +55 (11) 2608-7410

CANADA

Arjo Canada Inc.
90 Matheson Boulevard West
Suite 300
CA-MISSISSAUGA, ON, L5R 3R3
Tel/Tél: +1 905 238 7880
Free: +1 800 665 4831 Institutional
Free: +1 800 868 0441 Home Care
Fax: +1 905 238 7881
E-mail: info.canada@arjo.com

ČESKÁ REPUBLIKA

ArjoHuntleigh s.r.o.
Na Strži 1702/65
140 00 Praha 4
Tel: +420 549 254 252
Fax: +420 541 213 550

DANMARK

Arjo A/S
Vassingerødvej 52
DK-3540 LYNGE
Tel: +45 49 13 84 86
Fax: +45 49 13 84 87
E-mail:
dk_kundeservice@arjo.com

DEUTSCHLAND

Arjo GmbH
Peter-Sander-Strasse 10
DE-55252 MAINZ-KASTEL
Tel: +49 (0) 6134 186 0
Fax: +49 (0) 6134 186 160
E-mail: info-de@arjo.com

ESPAÑA

Arjo Ibérica S.L.
Parque Empresarial Rivas Futura, C/Marie
Curie 5
Edificio Alfa Planta 6 oficina 6.1.-.62
ES-28521 Rivas Vacia, MADRID
Tel: +34 93 583 11 20
Fax: +34 93 583 11 22
E-mail: info.es@arjo.com

FRANCE

Arjo SAS
2 Avenue Alcide de Gasperi
CS 70133
FR-59436 RONCQ CEDEX
Tél: +33 (0) 3 20 28 13 13
Fax: +33 (0) 3 20 28 13 14
E-mail: info.france@arjo.com

HONG KONG

ArjoHuntleigh (Hong Kong) Limited
Room 411-414, 4/F, Manhattan Centre,
8 Kwai Cheong Road, Kwai Chung, N.T.,
HONG KONG
Tel: +852 2960 7668
Fax: +852 2960 1711

ITALIA

Arjo Italia S.p.A.
Via Giacomo Peroni 400-402
IT-00131 ROMA
Tel: +39 (0) 6 87426211
Fax: +39 (0) 6 87426222
E-mail: Italy.promo@arjo.com

MIDDLE EAST

Huntleigh Middle East
Office G005 - Nucleotide Complex,
Biotechnology & Research Park,
P.O.Box 214742, Dubai,
United Arab Emirates
Tel: +971 (0)4 447 0942
E-mail: Info.ME@arjo.com

NEDERLAND

Arjo BV
Biezenwei 21
4004 MB TIEL
Postbus 6116
4000 HC TIEL
Tel: +31 (0) 344 64 08 00
Fax: +31 (0) 344 64 08 85
E-mail: info.nl@arjo.com

NEW ZEALAND

Arjo Ltd
34 Vestey Drive
Mount Wellington
NZ-AUCKLAND 1060
Tel: +64 (0) 9 573 5344
Free Call: 0800 000 151
Fax: +64 (0) 9 573 5384
E-mail: nz.info@Arjo.com

NORGE

Arjo Norway AS
Olaf Helsets vei 5
N-0694 OSLO
Tel: +47 22 08 00 50
Faks: +47 22 08 00 51
E-mail: no.kundeservice@arjo.com

ÖSTERREICH

Arjo GmbH
Lemböckgasse 49 / Stiege A / 4.OG
A-1230 Wien
Tel: +43 1 8 66 56
Fax: +43 1 866 56 7000

POLSKA

Arjo Polska Sp. z o.o.
ul. Ks Piotra Wawrzyniaka 2
PL-62-052 KOMORNIKI (Poznań)
Tel: +48 61 662 15 50
Fax: +48 61 662 15 90
E-mail: arjo@arjo.com

PORTUGAL

Arjo em Portugal
MAQUET Portugal, Lda.
(Distribuidor Exclusivo)
Rua Poeta Bocage n.º 2 - 2G
PT-1600-233 Lisboa
Tel: +351 214 189 815
Fax: +351 214 177 413
E-mail: Portugal@arjo.com

SUISSE / SCHWEIZ

Arjo AG
Fabrikstrasse 8
Postfach
CH-4614 HÄGENDORF
Tél/Tel: +41 (0) 61 337 97 77
Fax: +41 (0) 61 311 97 42

SUOMI

Arjo Scandinavia AB
Riihitontuntie 7 C
02200 Espoo
Finland
Puh: +358 9 6824 1260
E-mail: Asiakaspalvelu.finland@arjo.com

SVERIGE

Arjo International HQ
Hans Michelsensgatan 10
SE-211 20 MALMÖ
Tel: +46 (0) 10 494 7760
Fax: +46 (0) 10 494 7761
E-mail: kundservice@arjo.com

UNITED KINGDOM

Arjo UK and Ireland
Houghton Hall Park
Houghton Regis
UK-DUNSTABLE LU5 5XF
Tel: +44 (0) 1582 745 700
Fax: +44 (0) 1582 745 745
E-mail: sales.admin@arjo.com

USA

Arjo Inc.
2349 W Lake Street Suite 250
US-Addison, IL 60101
Tel: +1 630 307 2756
Free: +1 800 323 1245 Institutional
Free: +1 800 868 0441 Home Care
Fax: +1 630 307 6195
E-mail: us.info@arjo.com

Arjo Japan K.K.

東京都港区東新橋二丁目 11 番 3 号第 2 小川ビル 3 階
電話 : +81 (0) 3-6435-6401

Address page - REV 21: 02/2018

At Arjo, we are committed to improving the everyday lives of people affected by reduced mobility and age-related health challenges. With products and solutions that ensure ergonomic patient handling, personal hygiene, disinfection, diagnostics, and the effective prevention of pressure ulcers and venous thromboembolism, we help professionals across care environments to continually raise the standard of safe and dignified care. Everything we do, we do with people in mind.



ArjoHuntleigh AB
Hans Michelsensgatan 10
211 20 Malmö, Sweden
www.arjo.com

arjo

CE
0086