



# **6550/6550KGEU**

## **Portable Wheelchair Scale**

### **Service Manual**

## **FCC COMPLIANCE STATEMENT**

This equipment generates uses and can radiate radio frequency and if not installed and used in accordance with the instruction manual, may cause interference to radio communications. It has been tested and found to comply with the limits for a Class A computing device pursuant to Subpart J of Part 15 of FCC rules, which are designed to provide reasonable protection against such interference when operated in a commercial environment. Operation of this equipment in a residential area may cause interference in which case the user will be responsible to take whatever measures necessary to correct the interference.

You may find the booklet "How to Identify and Resolve Radio TV Interference Problems" prepared by the Federal Communications Commission helpful. It is available from the U.S. Government Printing Office, Washington, D.C. 20402. Stock No. 001-000-00315-4.

## **PROPER DISPOSAL**

When this device reaches the end of its useful life, it must be properly disposed of. It must not be disposed of as unsorted municipal waste. Within the European Union, this device should be returned to the distributor from where it was purchased for proper disposal. This is in accordance with EU Directive 2002/96/EC. Within North America, the device should be disposed of in accordance with the local laws regarding the disposal of waste electrical and electronic equipment.

It is everyone's responsibility to help maintain the environment and to reduce the effects of hazardous substances contained in electrical and electronic equipment on human health. Please do your part by making certain that this device is properly disposed of. The symbol shown to the right indicates that this device must not be disposed of in unsorted municipal waste programs.



## **COPYRIGHT**

All rights reserved. Reproduction or use, without expressed written permission, of editorial or pictorial content, in any manner, is prohibited. No patent liability is assumed with respect to the use of the information contained herein.

## **DISCLAIMER**

While every precaution has been taken in the preparation of this manual, the Seller assumes no responsibility for errors or omissions. Neither is any liability assumed for damages resulting from use of the information contained herein. All instructions and diagrams have been checked for accuracy and ease of application; however, success and safety in working with tools depend to a great extent upon the individual accuracy, skill and caution. For this reason, the Seller is not able to guarantee the result of any procedure contained herein. Nor can they assume responsibility for any damage to property or injury to persons occasioned from the procedures. Persons engaging the procedures do so entirely at their own risk.



## CE DECLARATION OF CONFORMITY

<b>Instrument Model:</b>	<b>6500KGEU, 6550KGEU, 6854KGEU, 6800KGEU, 6854KGEUDHR, 6855KGEU, 6856KGEU, 6857KGEUDHR, 6868KGEU, 6875KGEU, 6876KGEU, BRW1000KGEU, CRM-1000D, GP-400KGEU</b>
<b>Manufacturer:</b>	Cardinal Scale Manufacturing Company Detecto Scale 203 East Daugherty Street Webb City, Missouri 64870 USA Telephone No. + 417 673 4631 Fax No. + 417 673 5001
<b>Type Approval Certificate(s):</b>	MV2 DK0199.436 Revision 1 LFB250M,LFB250P R60/1991-DK-00.02
<b>Test Certificate(s):</b>	MV2 DANAK-191374 LFB250M, LFB250P DANAK-193262
<b>Notified Body Issuing Approval for Module B: EU Type Examination (Annex II.2 of 2014/31/EU):</b>	0199-Delta

Conformity to the following Directives is demonstrated by reference to the following harmonized standards or technical documentation

<u>Applicable Directives</u>	<u>Harmonized Standards or Other Technical Documentation</u>
<b>Directive on Non-Automatic Weighing Instruments (2014/31) including all Essential Requirements of Annex I:</b>	EN45501:1992/Module B
<b>Directive on Electromagnetic Compatibility (2014/35):</b>	EN61000-4-2 for Electrostatic discharge immunity and EN61000-4-3 for Radiated, radio frequency, and electromagnetic field immunity test.
<b>Directive on Electrical Equipment designed to use within certain Voltage limits (2006/95):</b>	EN61000-4-7 for General guide on harmonics measurements and instrumentation for power supply systems and connected equipment.
<b>Directive for Medical Devices, 93/42/EU Class I Medical Device</b>	EN ISO13485:2012 Certificate 1004213 issued by Orion Registrar, Inc.

The Technical Construction File required by this Directive is maintained at the corporate headquarters of Cardinal Scale Manufacturing Company.

This declaration is issued under the sole responsibility of the manufacturer.

Signed for and on behalf of Cardinal Scale Manufacturing 203 East Daugherty, Webb City MO, 64870:

Mark Levels  
Manager, Quality Assurance

2/23/2017

Rev D

EU-6550KGEU

**COMPATIBILITY OF MODULES**

Ref.: WELMEC 2 (2000)

**Non-Automatic Weighing Instrument, single-interval.**

Certificate of EU Type-Approval N°:

TAC: DK0199.436

**INDICATOR**

A/D (Module 1)

Type: MV2

Accuracy class according to EN 45501 and OIML R76:

Class<sub>ind</sub> ( I, II, III or IIII ) III

Maximum number of verification scale intervals (n<sub>max</sub>):

n<sub>ind</sub> 6000

Fraction of maximum permissible error (mpe):

p<sub>1</sub> 0.5

Load cell excitation voltage:

U<sub>exc</sub> [ Vdc ] 5

Minimum input-voltage per verification scale interval:

Δu<sub>min</sub> [ μV ] 0.83

Minimum load cell impedance:

R<sub>Lmin</sub> [ Ω ] 87

Coefficient of temperature of the span error:

E<sub>s</sub> [ % / 25°C ] 0.006

Coefficient of resistance for the wires in the J-box cable:

S<sub>x</sub> [ % / Ω ] 0.0152

Specific J-box cable-Length to the junction box for load cells:

(L/A)<sub>max</sub> [ m / mm<sup>2</sup> ] 127

Load cell interface:

4-wire (no sense)

Additive tare, if available:

T<sup>+</sup> [ % of Max ] 5

Initial zero setting range:

IZSR [ % of Max ] -2 / 2

Temperature range:

T<sub>min</sub> / T<sub>max</sub> [ °C ] -10 / 40

Test report (TR), Test Certificate (TC) or OIML Certificate of Conformity:

DANAK-1913746

**LOAD RECEPTOR**

(Module 2)

Type:

Platform

Construction:

Fraction of mpe:

p<sub>2</sub> 0.5

Number of load cells:

N 4

Reduction ratio of the load transmitting device:

R=F<sub>M</sub> / F<sub>L</sub> 1

Dead load of load receptor:

DL [ % of Max ] 38.95

Non uniform distribution of the load:

NUD [ % of Max ] 20

Correction factor:

Q = 1 + (DL + T<sup>+</sup> + IZSR<sup>+</sup> + NUD) / 100 1.6595

**LOAD CELL**

ANALOG (Module 3)

Type:

LFB-250P

Accuracy class according to OIML R60:

Class<sub>LC</sub> ( A, B, C or D ) C

Maximum number of load cell intervals:

n<sub>LC</sub> 3000

Fraction of mpe:

p<sub>3</sub> 0.7

Rated output (sensitivity):

C [ mV / V ] 2.2

Input resistance of single load cell:

R<sub>LC</sub> [ Ω ] 350

Minimum load cell verification interval: (v<sub>min%</sub> = 100 / Y)

v<sub>min%</sub> [ % of E<sub>max</sub> ] 0.02

Rated capacity:

E<sub>max</sub> [ kg ] 125

Minimum dead load, relative:

(E<sub>min</sub> / E<sub>max</sub>) \* 100 [ % ] 0

Temperature range:

T<sub>min</sub> / T<sub>max</sub> [ °C ] -10 / 40

Test report (TR) or Test Certificate (TC/OIML) as appropriate:

R60/1991-DK-00.02

**COMPLETE WEIGHING INSTRUMENT**

Single-interval

Manufacturer:

Detecto

Type:

6550KGEU

Accuracy class according to EN 45501 and OIML R76:

Class<sub>WI</sub> ( I, II, III or IIII ) III

Fractions: p<sub>1</sub> = p<sub>1</sub><sup>2</sup> + p<sub>2</sub><sup>2</sup> + p<sub>3</sub><sup>2</sup>:

p<sub>1</sub> 1.0

Maximum capacity:

Max [ kg ] 300

Number of verification scale intervals:

n 3000

Verification scale interval:

e [ kg ] 0.1

Utilisation ratio of the load cell:

α = (Max / E<sub>max</sub>) \* (R / N) 0.60

Input voltage (from the load cell s):

Δ<sub>u</sub> = C \* U<sub>exc</sub> \* α \* 1000 / n [ μV/e ] 2.20

Cross-section of each wire in the J-box cable:

A [ mm<sup>2</sup> ] 0.22

J-box cable-Length:

L [ m ] 5

Temperature range to be marked on the instrument: Not required

T<sub>min</sub> / T<sub>max</sub> [ °C ]

Peripheral Equipment subject to legal control:

Acceptance criteria for compatibility			Passed, provided no result below is < 0	
Class <sub>WI</sub>	<=	Class <sub>ind</sub> & Class <sub>LC</sub> (WELMEC 2: 1)	Class <sub>WI</sub> :	<b>PASSED</b>
pi	<=	1 (R76: 3.5.4.1)	1 - pi =	<b>0.0</b>
n	<=	n <sub>max</sub> for the class (R76: 3.2)	n <sub>max</sub> for the class - n =	<b>7000</b>
n	<=	n <sub>ind</sub> (WELMEC 2: 4)	n <sub>ind</sub> - n =	<b>3000</b>
n	<=	n <sub>LC</sub> (R76: 4.12.2)	n <sub>LC</sub> - n =	<b>0</b>
E <sub>min</sub>	<=	DL * R / N (WELMEC 2: 6d)	(DL * R / N) - E <sub>min</sub> =	<b>29.2125</b>
v <sub>min</sub> * √N / R	<=	e (R76: 4.12.3)	e - (v <sub>min</sub> * √N / R) =	<b>0.050</b>
or (if v <sub>min</sub> is not given)			Alternative solutions: ↑ ↓	
(E <sub>max</sub> / n <sub>LC</sub> ) * (√N / R)	<=	e (WELMEC 2: 7)	e - ((E <sub>max</sub> / n <sub>LC</sub> ) * (√N / R)) =	
Δu <sub>min</sub>	<=	Δu (WELMEC 2: 8)	Δu - Δu <sub>min</sub> =	<b>1.37</b>
R <sub>Lmin</sub>	<=	R <sub>LC</sub> / N (WELMEC 2: 9)	(R <sub>LC</sub> / N) - R <sub>Lmin</sub> =	<b>1</b>
L / A	<=	(L / A) <sub>max</sub> <sup>WI</sup> (WELMEC 2: 10)	(L / A) <sub>max</sub> <sup>WI</sup> - (L / A) =	<b>347</b>
T <sub>range</sub>	<=	T <sub>max</sub> - T <sub>min</sub> (R76: 3.9.2.2)	(T <sub>max</sub> - T <sub>min</sub> ) - T <sub>range</sub> =	<b>20</b>
Q * Max * R / N	<=	E <sub>max</sub> (R76: 4.12.1)	E <sub>max</sub> - (Q * Max * R / N) =	<b>0.5</b>

Signature and date:

**Conclusion . . . . . PASSED**

This is an authentic document made from the program:  
"Compatibility of NAWI-modules version 3.0".

# CARE AND CLEANING

## Indicator

The indicator contains no user-serviceable parts and maintenance should be limited to an occasional cleaning and battery replacement as required.

## General Cleaning Instructions

- Do not submerge the scale or indicator in water, pour or spray water directly on them to clean. The scale and indicator are not waterproof and covering them with water will damage them and void the warranty.
- Always remove power before cleaning.
- When cleaning, use only damp soft cloths or plastic scouring pads for cleaning cloth and a mild non-abrasive detergent.
- **DO NOT** use acetone, thinner or other volatile solvents for cleaning.
- **DO NOT** use things which will scratch the surface, such as steel pads, wire brushes and scrapers.

## Powder Painted Steel Care and Cleaning

While powder painted steel is attractive and so durable that it will last many years longer than ordinary painted steel, it is desirable to clean it thoroughly on a routine basis. There are three basic things that should be remembered when cleaning powder painted steel.

1. Do not use wire brushes, abrasives, or cleaning tools such as steel pads and scrapers, which will scratch the painted surface. Instead, use soft cloths or plastic scouring pads for cleaning. Clean food equipment frequently to avoid build-up.
2. When possible, use treated water. Hard water can leave behind deposits. Soft water is much gentler on the painted steel's surface.
3. Avoid the use of acetone, thinner or other volatile solvents and abrasive type cleaners for cleaning. If required, a mild solvent such as mineral spirits can be used to remove oil, grease, tars, wax, and similar substances. Use a cloth dampened with mineral spirits and apply only to areas that are contaminated. Follow up the use of this mild solvent with detergent cleaning and rinsing.



# 6550/6550KGEU

## PORTABLE WHEELCHAIR SCALE

### TEST PROCEDURE

- A. EQUIPMENT REQUIRED
- B. SETUP
- C. SCALE TRIM ADJUSTMENT
- D. CALIBRATION
- E. FINAL TEST



## A. Equipment Required

Scale under test

Standard Hand tools

Test Weights: Appropriate certified weights to accomplish the linearity tests

## B. Setup - HI RES MODE (MV2 ONLY, OTHERWISE GO TO STEP C.)

1. Assemble scale.
2. Plug unit into power.
3. For **KGEU** models, first go to the setup table and Calibrate the scale. Next, return here to the initiate the HI RES mode for the scale trim adjustment. Then recheck the capacity weight and recalibrate if necessary.
4. Enter Setup Review:  
With the MV2 on press and hold the **CLEAR (←)** key  
When the screen says SETUP  
Release the **CLEAR (←)** key  
Press **ENTER** until you see the **HIGH-RESOLUTION** prompt  
Change **HIGH RESOLUTION** to YES and press **ENTER**  
Exit setup review mode

## C. Scale Trim Adjustment

1. Gain access to the junction box and remove the cover.
2. Place a test weight of at least 25 percent of scale capacity on each corner, one at a time, and record each displayed weight.
3. Place test weight on the corner with the highest displayed weight and adjust appropriate trim potentiometer counterclockwise until corner reading agrees with the lowest weight reading.
4. Repeat Step No. 3 until all corners are within tolerance. For tolerance values, refer to the Linearity Check Table in the **E. Final Test** section.
5. If any trim pot reaches the end of adjustment in the CCW direction then turn all potentiometers clockwise 25 turns or until a click is heard. Now turn all potentiometers counterclockwise 1 (one) turn and repeat steps 2 - 4.
6. Turn the power off.

## D. Calibration

1. To begin Calibration and Setup, make sure the MV1 indicator is turned on.
2. Next, looking at the front of the MV1, remove the two screws from the left end cap and remove the end cap.
3. Locate the calibration switch access hole near the bottom of the side panel, and insert a small hex wrench or tool through the access hole.
4. Press and hold the calibration switch until the display changes to show SETUP in large letters at the top of the display, and SCALE in smaller letters at the bottom.
5. Release the calibration switch. You are now ready to perform calibration.
6. During setup and calibration, pressing the **PRINT/ENTER** key will cause the data displayed, to be retained and the indicator to advance to the next prompt. Change the value by entering the new data using the numeric keypad, and then pressing the **PRINT/ENTER** key.
7. Follow the prompts listed in the MV1 SETUP TABLE.



<b>MV1 SETUP TABLE</b>	
<b>CAPACITY =</b>	<b>1000</b>
<b>OIML =</b>	<b>NO</b>
<b>UNITS =</b>	<b>2</b>
<b>INTERVAL =</b>	<b>2</b>
<b>dECIMAL =</b>	<b>1</b>
<b>MOTION RANGE =</b>	<b>2</b>
<b>SAMPLE RATE =</b>	<b>2</b>
<b>ZERO LIMIT =</b>	<b>no</b>
<b>POWER UP ZERO =</b>	<b>no</b>
<b>ZERO TRACKING =</b>	<b>3</b>
<b>FILTER MOdE =</b>	<b>2</b>
<b>FILTER LEVEL =</b>	<b>0</b>
<b>CALiBRATE =</b>	<b>YES</b>
<b>NUM CAL POINTS =</b>	<b>1</b>
<b>LOAdEd CAL WT =</b>	<b>APPLY FULL CAPACITY WEIGHT</b>
<b>UNLOAD</b>	<b>REMOVE TEST WEIGHTS</b>
<b>GRAVITY ENAbLE =</b>	<b>no</b>
<b>HOLd MOdE =</b>	<b>2</b>
<b>BANd =</b>	<b>99</b>
<b>LANGUAGE =</b>	<b>0</b>
<b>bACKLIGHT =</b>	<b>150</b>
<b>KEYPAdbEEP =</b>	<b>YES</b>
<b>SLEEP MOdE =</b>	<b>4</b>
<b>AUTO SHUT OFF =</b>	<b>2</b>
<b>KEY dISAbLE =</b>	<b>0</b>
<b>ENAbLE Id =</b>	<b>no</b>
<b>bARCOdE =</b>	<b>no</b>
<b>USE HEIGHT =</b>	<b>no</b>
<b>bOdY MASS IdX =</b>	<b>YES</b>
<b>HI RESOLUTION =</b>	<b>no</b>
<b>RS232 MOdE =</b>	<b>3</b>
<b>bAUd RATE =</b>	<b>3</b>
<b>PRINTER TYPE =</b>	<b>0</b>
<b>END OF PRINT =</b>	<b>0</b>
<b>USb MOdE =</b>	<b>1</b>
<b>YEAR [YYYY] =</b>	<b>Enter current year</b>
<b>MONTH [1-12] =</b>	<b>Enter current month</b>
<b>dAY [1-31] =.</b>	<b>Enter current day of the month</b>
<b>HOUR [0-23] =</b>	<b>Enter current hour in 24-hour format</b>
<b>MINUTE [0-59] =</b>	<b>Enter current minute</b>
<b>SECONd [0-59] =</b>	<b>Enter current second</b>
<b>24 HOUR TIME =</b>	<b>no</b>

<b>MV2 SETUP TABLE</b>	
<b>CAPACITY =</b>	<b>IF USING LB WEIGHTS, SET @ 400 (AFTER CAL RESET TO 300)</b>
<b>OIML =</b>	<b>YES</b>
<b>INTERVAL =</b>	<b>1</b>
<b>dECIMAL =</b>	<b>1</b>
<b>MOTION RANGE =</b>	<b>2</b>
<b>SAMPLE RATE =</b>	<b>4</b>
<b>ZERO LIMIT =</b>	<b>YES</b>
<b>POWER UP ZERO =</b>	<b>YES</b>
<b>ZERO TRACKING =</b>	<b>1</b>
<b>FILTER MOdE =</b>	<b>2</b>
<b>FILTER LEVEL =</b>	<b>0</b>
<b>CALiBRATE =</b>	<b>YES</b>
<b>NUM CAL POINTS =</b>	<b>1</b>
<b>LOADEd CAL WT =</b>	<b>APPLY FULL CAPACITY WEIGHT</b>
<b>UNLOAD</b>	<b>REMOVE TEST WEIGHTS</b>
<b>GRAVITY ENAbLE =</b>	<b>no</b>
<b>HOLd MOdE =</b>	<b>0</b>
<b>LANGUAGE =</b>	<b>0</b>
<b>bACKLiGHT =</b>	<b>150</b>
<b>KEYPAd bEEP =</b>	<b>YES</b>
<b>SLEEP MOdE =</b>	<b>4</b>
<b>AUTO SHUT OFF =</b>	<b>2</b>
<b>KEY dISAbLE =</b>	<b>0</b>
<b>ENAbLE Id =</b>	<b>no</b>
<b>bARCOdE =</b>	<b>no</b>
<b>USE HEIGHT =</b>	<b>no</b>
<b>bOdY MASS IdX =</b>	<b>YES</b>
<b>HI RESOLUTION =</b>	<b>YES</b>
<b>RS232 MOdE =</b>	<b>3</b>
<b>bAUd RATE =</b>	<b>3</b>
<b>PRINTER TYPE =</b>	<b>0</b>
<b>END OF PRINT =</b>	<b>0</b>
<b>USb MOdE =</b>	<b>1</b>
<b>YEAR [YYYY] =</b>	<b>Enter current year</b>
<b>MONTH [1-12] =</b>	<b>Enter current month</b>
<b>dAY [1-31] =</b>	<b>Enter current day of the month</b>
<b>HOUR [0-23] =</b>	<b>Enter current hour in 24-hour format</b>
<b>MINUTE [0-59] =</b>	<b>Enter current minute</b>
<b>SECONd [0-59] =</b>	<b>Enter current second</b>
<b>24 HOUR TIME =</b>	<b>no</b>

## E. Final Test

1. Perform Corner Test using 1/4 capacity weights (positions 1-4). Use tolerances listed in the table below.
2. Perform Linearity test. Check both ascending and descending. See table below.
3. Install indicator cover (MV2).
4. For kg units calibrated using lb weights, reset the Cap = 300 after calibration.

### Linearity Check Table

#### 6550

Applied Weight	Tolerance			WEIGHT POS
0	0			
*200 lb	199.8 lb	To	200.2 lb	1,2,3,4
400 lb	399.8 lb	To	400.2 lb	1+4 Then 2+3
500 lb	499.8 lb-	To	500.2 lb+	5
900 lb	899.4 lb	To	900.6 lb	5+2+3 Then 5+1+4

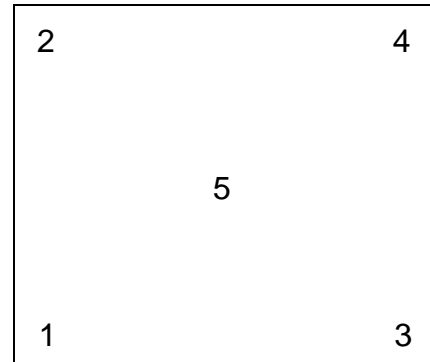

Weight Positions  
For Corner Test

#### 6550KGEU

Applied Weight	CALIBRATING WITH lb WEIGHTS			WEIGHT POS
	Tolerance			
0	0			
*200 lb (90.71 kg)	90.6 kg	To	90.8 kg	1,2,3,4
400 lb (181.43 kg)	181.3 kg	To	181.5 kg	1+4 Then 2+3
500 lb (226.79 kg)	226.6 kg	To	226.9 kg	5
800 lb (362.87 kg)	362.7 kg	To	363.0 kg	1+2+3+4

\*Use these weights for Corner Test

# APPLICATION OF ADHESIVE/ADHESIVE BACKED ITEMS

1. Use a clean cloth or paper towel to clean the surface with alcohol where the adhesive or adhesive backed item is to be applied.
2. After the alcohol has dried, use another clean dry cloth or paper towel to wipe the surface clean of all residue before the adhesive backed item is applied.
3. Apply the adhesive backed item immediately after the surface has dried. Be careful not to touch either the application surface or the adhesive with the bare hand.
4. Using a clean dry cloth or paper towel, rub out all air bubbles on flat items, such as keypads, labels, serial tags etc., by rubbing back and forth on the surface of the adhesive backed item while pressing firmly.

**NOTE: Be sure to press firmly on each corner to insure a good bond.**

5. For items that have foam tape, such as standoffs, apply the items square to the surface and hold in place with firm pressure for 5-10 seconds.

**NOTE: Most adhesive backed items will not attain full strength until after 24 hours. It is critical that the above procedure be followed to obtain the maximum bonding strength of any adhesive.**

## PARTS IDENTIFICATION

### Final Assembly – 0065-0707-0A

ITEM	QTY	PART NUMBER	DESCRIPTION
1	1	0065-0674-0A	6550 UNIV. BASE ASSY
2	16	6021-1257	SCW TRUSS-HEAD THREAD CUTTING 8-32X.375
3	1	0065-0676-08	BACK COVER PLATE, CR SHT 20 GA CQ
4	1	0065-0706-0A	6550 COLUMN ASSY
5	1	8555-B517-08	TRANSITION PLATE, 12 GA. SS SHT
6	1	8555-C508-08	MOUNT
7	2	6021-1032	SCW THUMB
8	7	6021-1454	1/4-20 x .750, ZP
9	1	MV1	INDICATOR (6550)
	1	MV2	INDICATOR (6550KGEU)
10	1	0065-B403-0A	INDICATOR CABLE
11	1	391RV204	ELASTIC STOP NUT
12	1	6540-1053	ENCLOSURE KNOB
13	1	6680-0250	SPACER .260 ID X .5 OD X .187 LONG NYLON
14	1	6024-1066	WASHER FLAT 1/4 X 1 X 1/16 TK Z-PLATE
15	1	6021-0950	SCW HEX-HEAD MACHINE-SCW 10-32X1.5
16	1	0065-B392-08	SAFETY PIN WARNING LABEL
17	1	593GR986	SERIAL TAG ASSY
18	1	6680-1043	GROMMET 1/4 ID X 5/8 OD X 1/8 TK PNL
19	1	5930-B104-08	LABEL: DETECTO LOGO W/WEBSITE (3" X 10")
20	1	6560-1046	THREADLOCKER HIGH STRENGTH, 0.5 ML CAPSULE
21	1	M220-0080-00	HAND TOOL 5/32 SHORT HEX KEY

## **PARTS IDENTIFICATION, CONT.**

### **Final Assembly – 0065-0707-0A**

#### **NOTES:**

1. Wire indicator and load cell cables as shown in schematic. Check to make sure that none of the indicator cables, or load cell cable wires are crossed, or touching where they connect to the trim board to avoid a short circuit. Route cables through available holes.
2. Ensure correct wiring occurs before addition of cover plate.
3. Calibrate and set up indicator per **Test Procedure** section.
4. Install serial tag on cover as shown.
5. Prepare surface per **APPLICATION OF ADHESIVE/ADHESIVE BACKED ITEMS** section before applying item 16, 17, 19.
6. Remove ramps and package separately for shipping.
7. Center label as closely as possible and offset from edge of deck using given dimensions.
8. Ensure Loctite packet (6560-1046), screws qty. 4 (6021-1812), and hex key (M220-0080-00) are added to package before shipping.

# PARTS IDENTIFICATION, CONT.

## Final Assembly – 0065-0707-0A

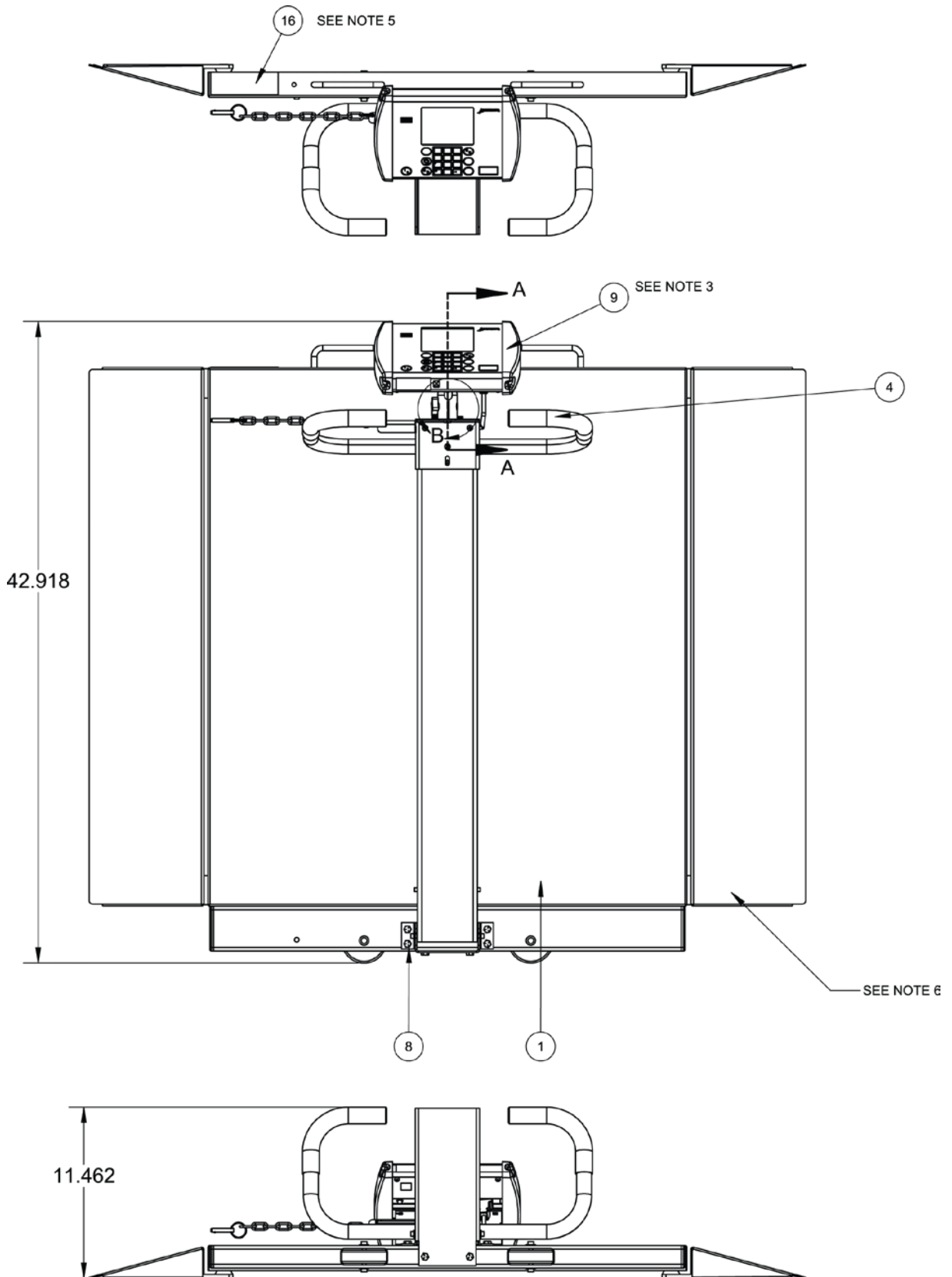

# PARTS IDENTIFICATION, CONT.

## Final Assembly – 0065-0707-0A

### Section A-A, Detail B, and Section C-C View

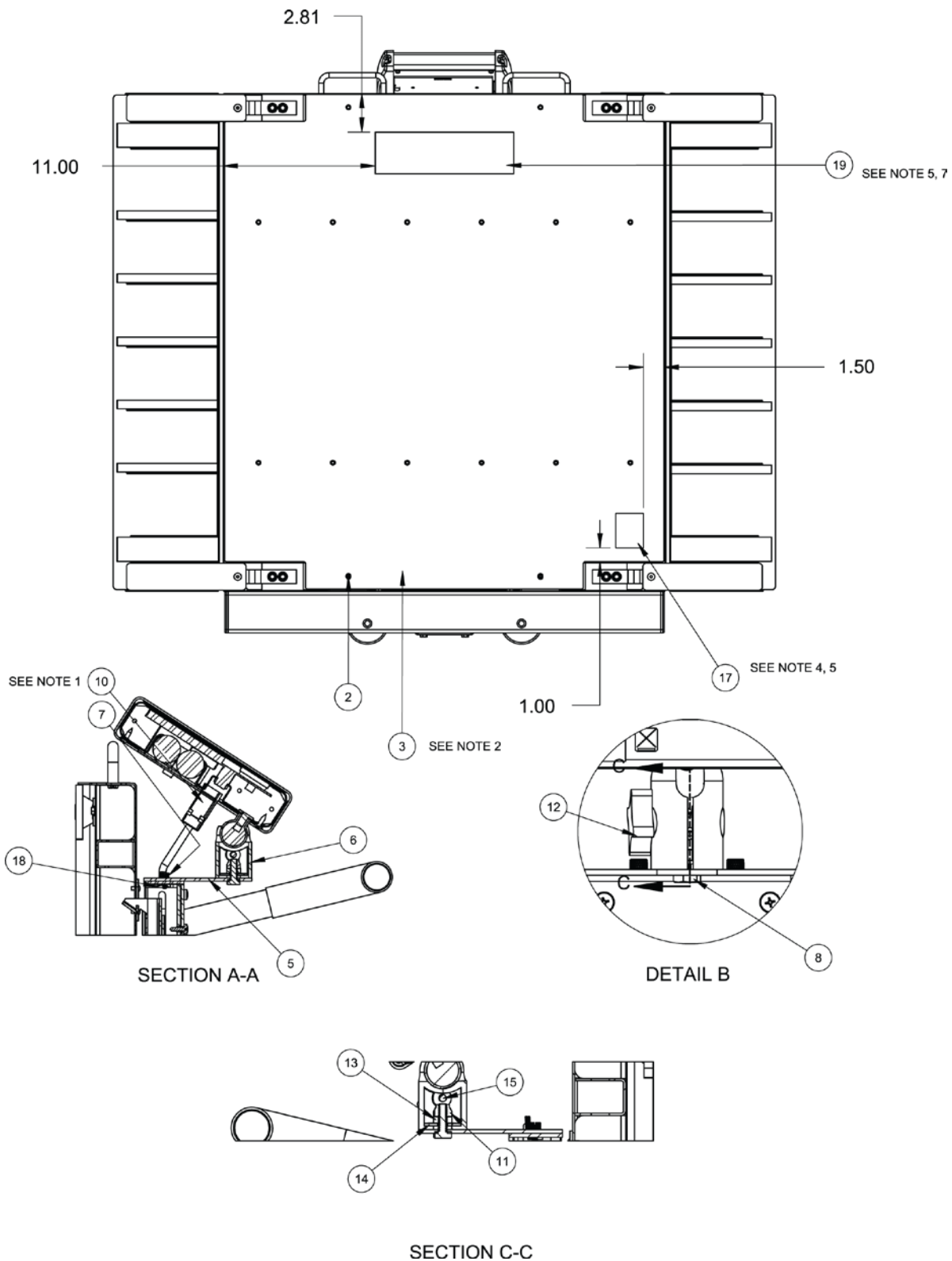



**PARTS IDENTIFICATION, CONT.**  
**Final Assembly – 0065-0707-0A, (Wiring Schematic)**

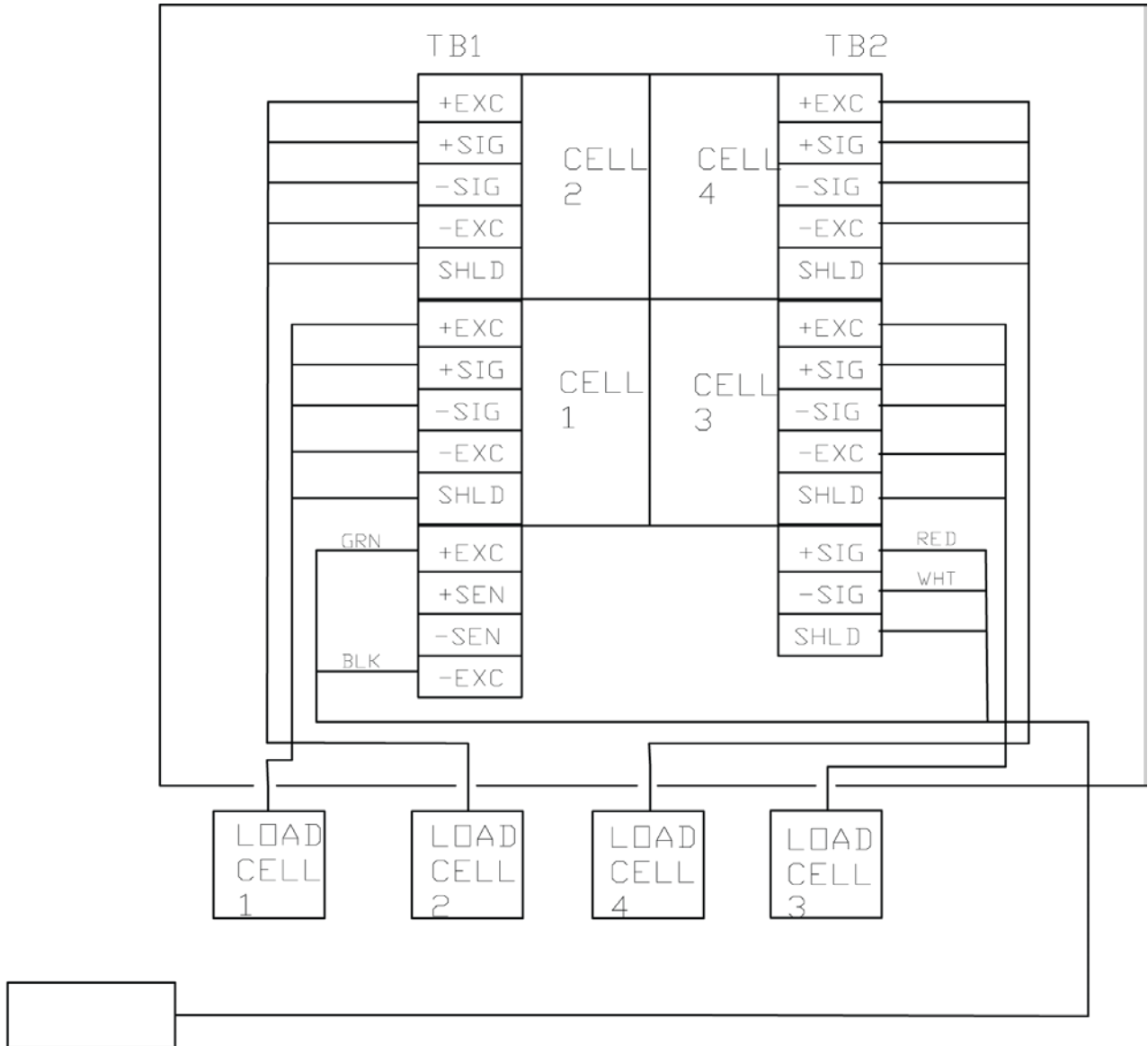

TO WEIGHT  
INDICATING  
INSTRUMENT

WIRING SCHEMATIC  
SEE NOTE 1.

**PARTS IDENTIFICATION, CONT.**  
**6550 Universal Base Assembly – 0065-0674-0A**

ITEM	QTY	PART NUMBER	DESCRIPTION
1	1	0065-0673-0A	6550 WB ASSY
2	1	0065-B359-08	LATCH PLATE, 14 GA, SS 304
3	1	0065-0713-08	HR BTTM BASE SINGLE COL. 3 X 1-1/2 X 3/16 WALL TUBING
4	4	0065-0716-08	LFB-250P
5	4	6540-1624	FOOT, RUBBER, BLACK
6	2	0065-0675-0A	6550 RAMP WELDMENT
7	2	0044-B178-08	HANDLE, 3/8 ROD, 304 SS
8	8	6021-2063	SCW SOCKET-HD CAP-SCREW .375-24
9	4	6021-1045	SCW HEX-HEAD MACHINE-SCW 10-32
10	4	6021-1812	SCW FLAT-HEAD SOCKET CAP, .25-20X.438
11	2	0065-0709-08	1/4" WHEEL SHAFT CR RD 1/4X12FT 1144 STRESSPROOF
12	2	574R473	WHEEL, 3'X7/8' 1/4 BORE
13	4	399R40	PUSH NUT, 1/4"
14	4	6680-0180	RIVET POP, BH SS 1/8 DIA x 250-312 GR
15	2	6540-1627	REC. TUBING CAP 1"X3" 8 GA. WALL
16	1	3502-C205-0A	TRIM BOARD
17	2	6021-0661	SCW PAN-HEAD MACHINE-SCW 06-32X.250
18	4	6021-1809	SCW HEX-HEAD CAP-SCREW, .375-16X.500
19	4	6024-0019	WASHER FLAT 3/8" SS
20	1	6560-1126	ADHESIVE LOCTITE 242 THRDLOCKR, REMOVABLE
21	1	0065-0717-08	6550/6549DS - DECK MAT - SAFTEY TRK RESILIENT BLK
22	2	0065-0718-08	6550/6549DS - RAMP MAT - SAFTEY TRK RESILIENT BLK
23	4	6610-5007	CABLE CLIP 1" x 1" GREY

## **PARTS IDENTIFICATION, CONT.**

### **6550 Universal Base Assembly – 0065-0674-0A**

#### **NOTES:**

1. Center and apply deck mat (0065-0717-08) and ramp mat (0065-0718-08) on top of deck (0065-0673-0A) and ramps (0065-0675-0A) before assembly.
2. HR BTTM base (0065-0713-08) must be attached to WB deck assembly (0065-0673-0A) before installation of load cells (0065-0716-08).
3. Apply Loctite (6560-1126) to threads of bolt before installation.
4. Ramps will be attached for alignment and positioning of load cells. Ramps will be removed with rubber mounts (6540-1624) left installed in load cells for calibration and packaging.
5. When installing screw (6021-1812) into rubber mount (6540-1624) for alignment purposes, be careful not to overtighten as this may shear rubber mount.
6. Ensure that screws (6021-1812) are set aside for individual packaging.
7. Ensure all wiring is routed to trim board through available holes in stiffeners.
8. In the event that end caps (6540-1627) are not fitting easily into the tubing (0065-0713-08), trim back flanges on end cap to ensure better fit.
9. Tighten load cell bolts (6021-2063) to 35 ft-lbs.
10. Tighten screws until snug and PCB is held firmly in place, do not overtighten for risk of crushing PCB.

# PARTS IDENTIFICATION, CONT.

## 6550 Universal Base Assembly – 0065-0674-0A

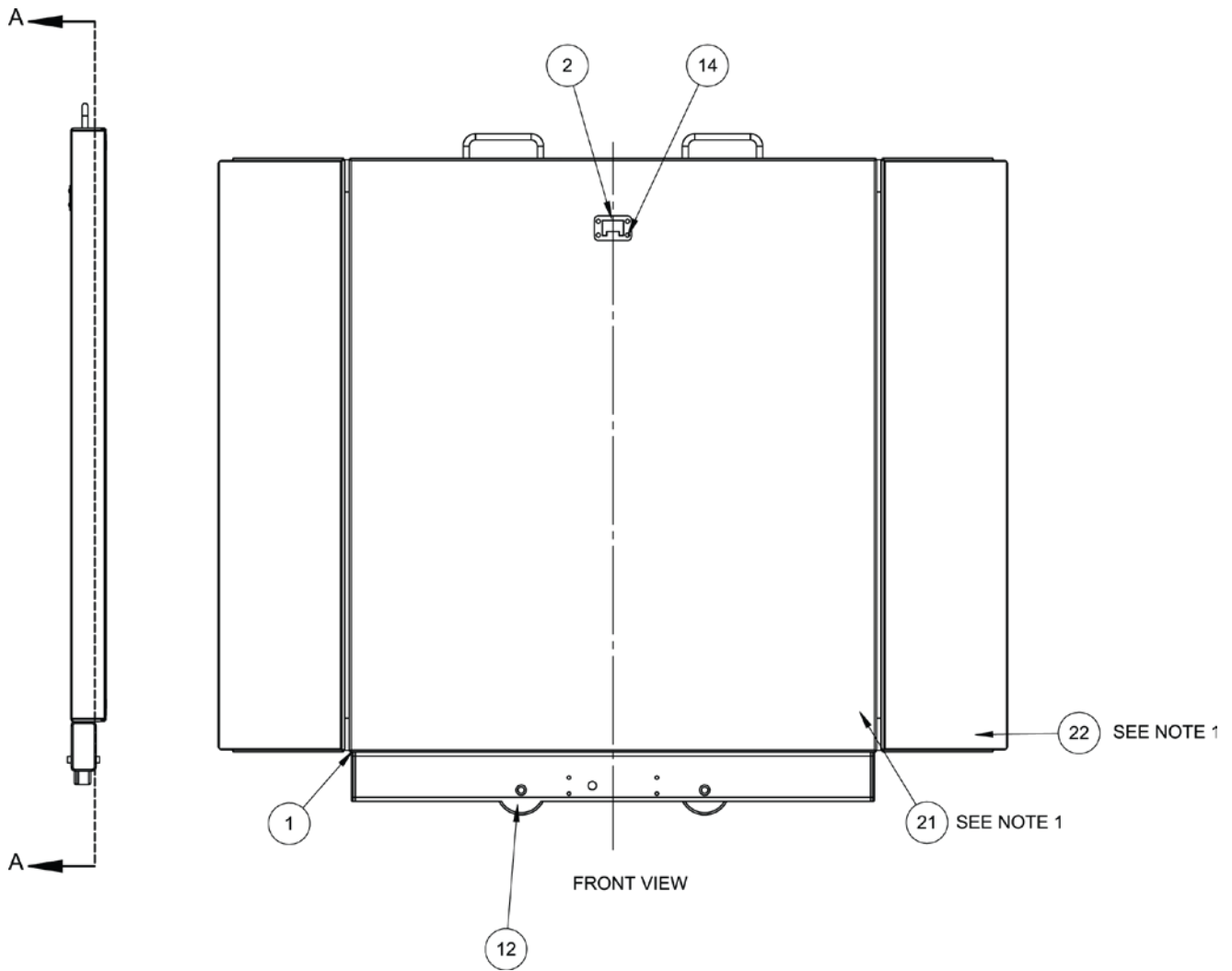

# PARTS IDENTIFICATION, CONT.

## 6550 Universal Base Assembly – 0065-0674-0A, Section B-B

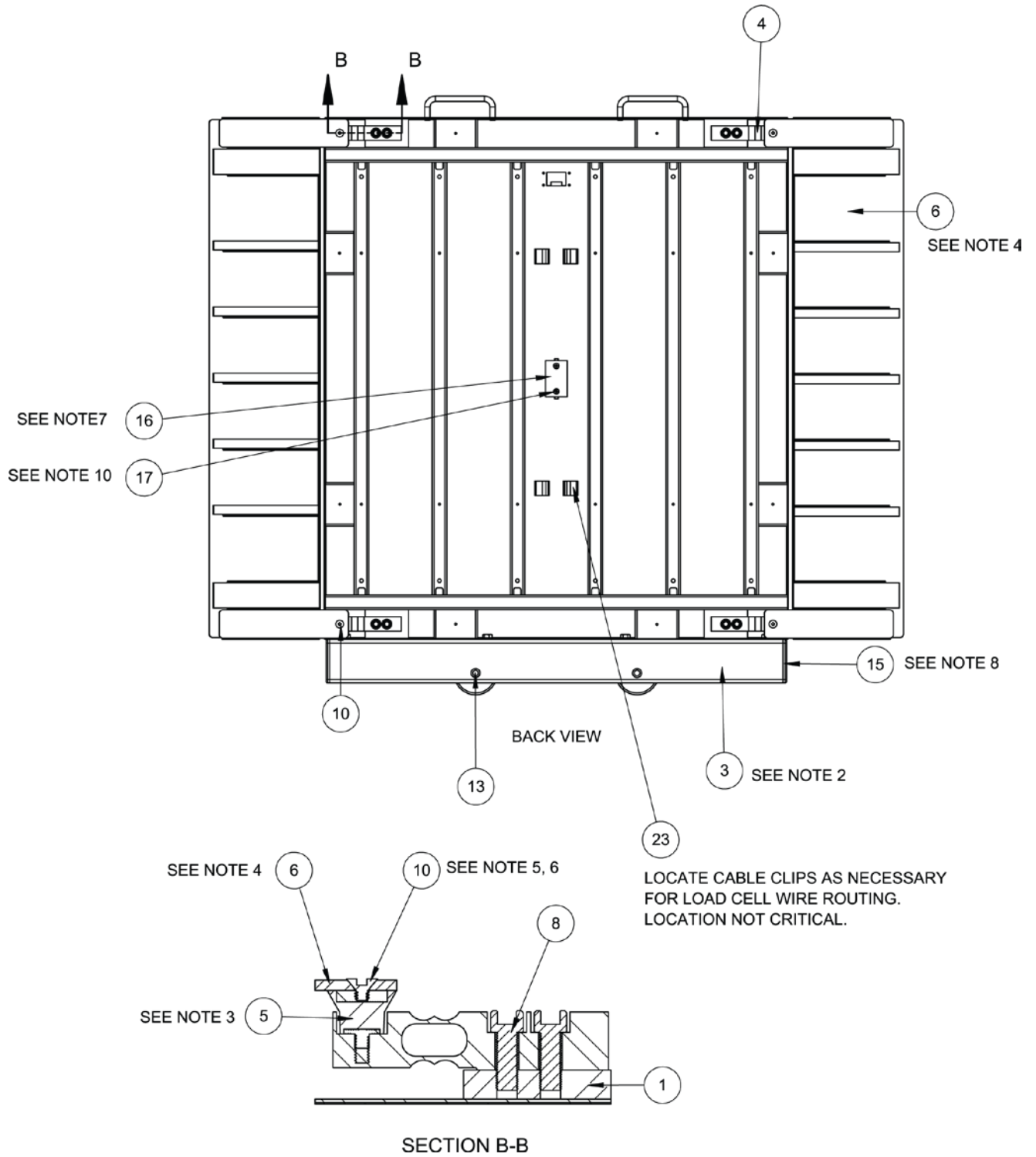

# PARTS IDENTIFICATION, CONT.

## 6550 Universal Base Assembly – 0065-0674-0A

### Section A-A and Detail C View

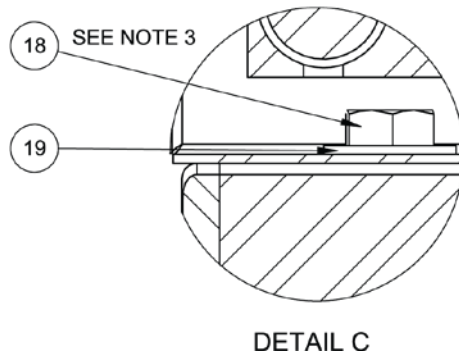
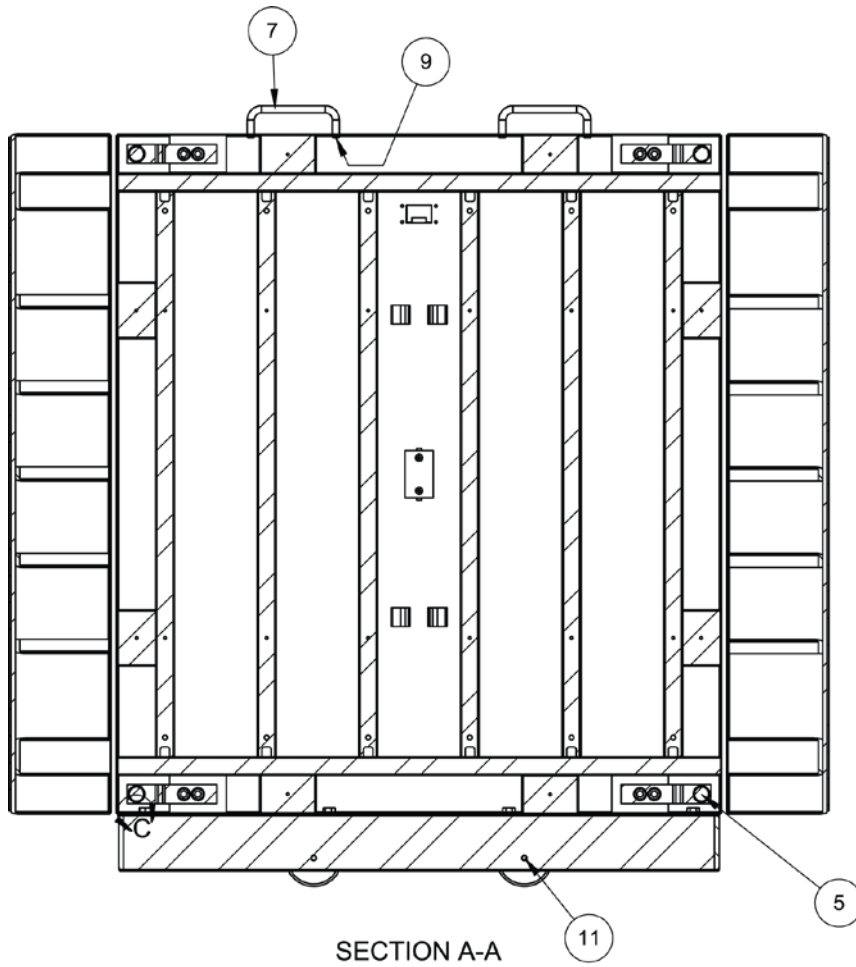

**PARTS IDENTIFICATION, CONT.**  
**Column and Latch Assembly – 0065-D339-0A**

ITEM	QTY	PART NUMBER	DESCRIPTION
1	1	0031-B014-08	SPACER
2	1	0065-B351-08	LINK BAR
3	1	0065-B352-0A	LATCH WELDMENT
4	1	0065-B373-0A	LOWER LATCH BLOCK
5	2	0065-B374-08	LATCH SPACER
6	1	0065-B442-08	LATCH SHAFT
7	1	0065-C338-0A	COLUMN WELDMENT
8	1	0065-C347-08	GUIDE, LATCH
9	1	0065-C443-08	GUIDE, LATCH LOWER
10	8	6021-0665	#6-32 X 3/8 PAN HD CAP SCW Z/P
11	1	6021-1020	SCW ROUND HEAD #10-32 X 0.375
12	1	6022-0027	SPRING, EXT. 1 7/8 LONG
13	1	6680-0030	WASHER FLAT 1/4 NYLON
14	1	6680-0038	WASHER FLAT #10 NYLON
16	.01	6560-0021	ADHESIVE LOCTITE 222-31 LO-STRENGTH 50ML

**NOTES:**

1. Check part fit prior to assembly. Remove paint buildup, material from column weldment as required to allow pivot pin installation and to allow latch to slide without binding.
2. None.
3. Apply Loctite (6560-0021) to bottom threads. Tighten until spacer is held against latch slide. The spacer must pass through the linkage, washer and latch guide.
4. Radius of item 4 must face up.

# PARTS IDENTIFICATION, CONT.

## Column and Latch Assembly – 0065-D339-0A

### Section A-A, Detail B, C and Section D-D View

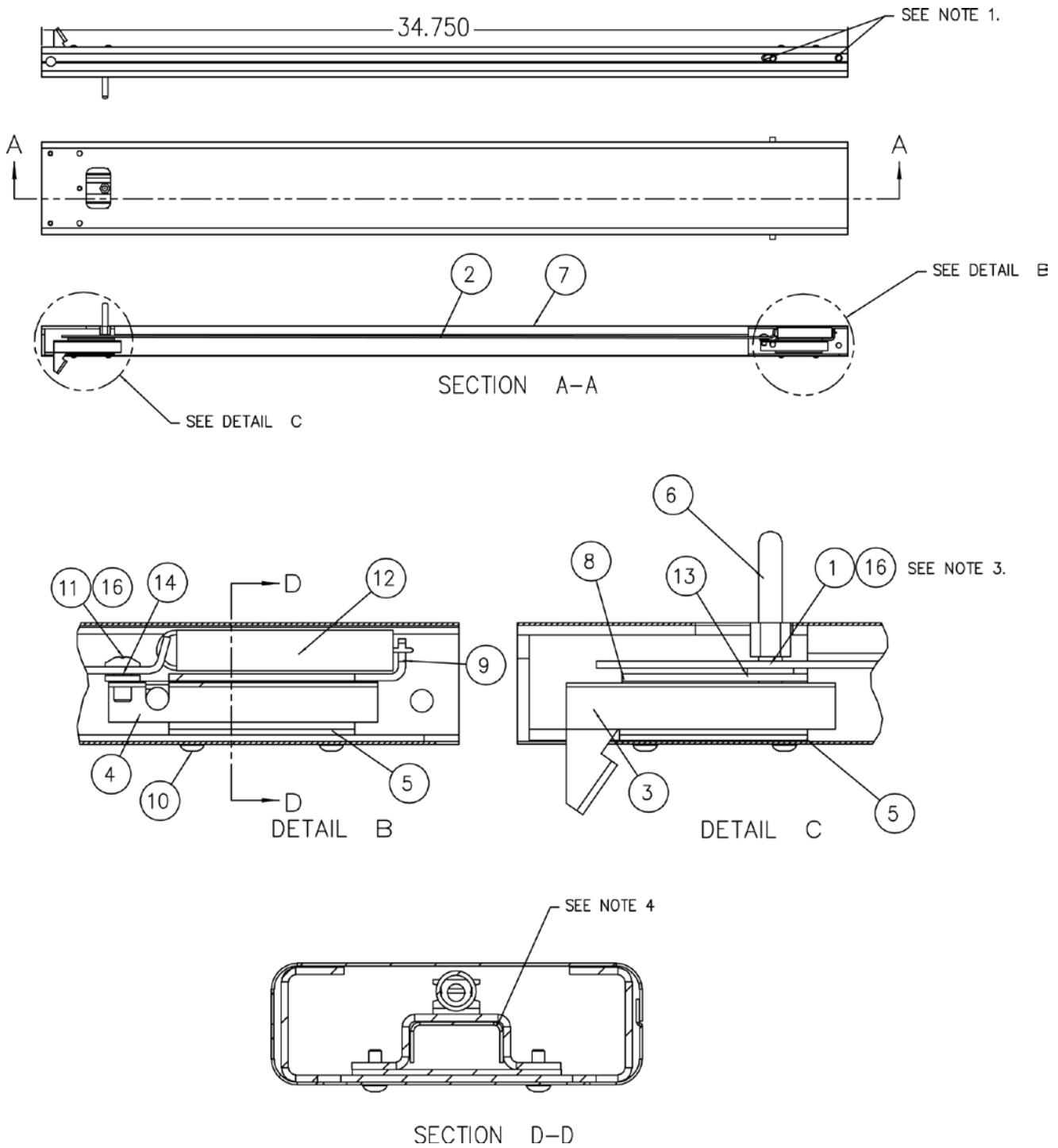



## PARTS IDENTIFICATION, CONT.

### Column Assembly – 0065-0706-0A, Section A-A

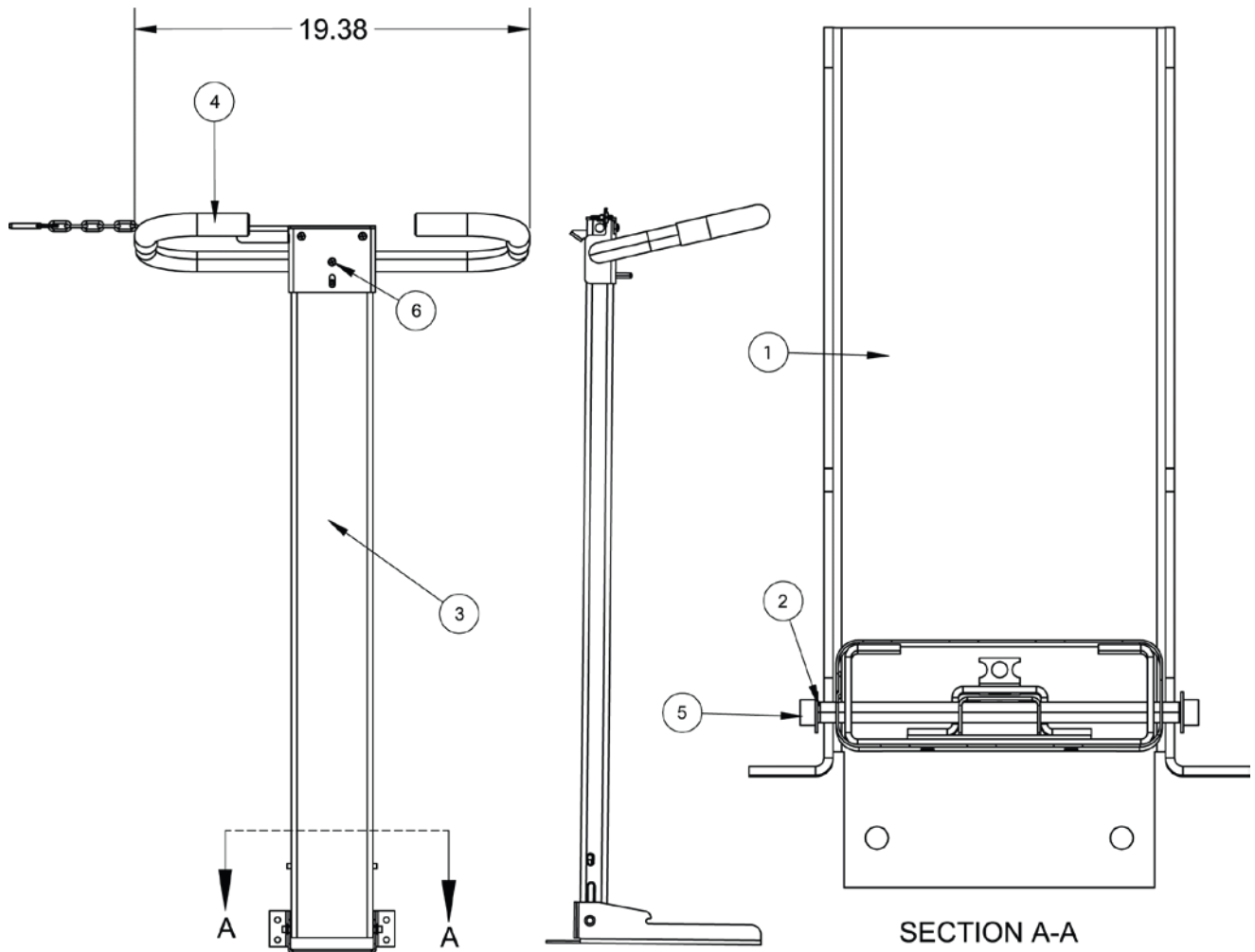

ITEM	QTY	PART NUMBER	DESCRIPTION
1	1	0065-0697-08	6549DS COLUMN SWIVEL BASE SS SHT 12 GA. X 48 X 96 #3/LASER FILM 304
2	1	0065-B342-08	PIN – COLUMN PIVOT, RD 1/4 SS
3	1	0065-D339-0A	COLUMN AND LATCH ASSEMBLY
4	1	0065-C391-0A	HANDLE ASSEMBLY
5	2	399R40	1/4 PUSH NUT
6	3	6021-1006	SCW ROUNDHEAD SEF-TAP 10-32X.50

## PARTS IDENTIFICATION, CONT.

### Handle Assembly – 0065-C391-0A

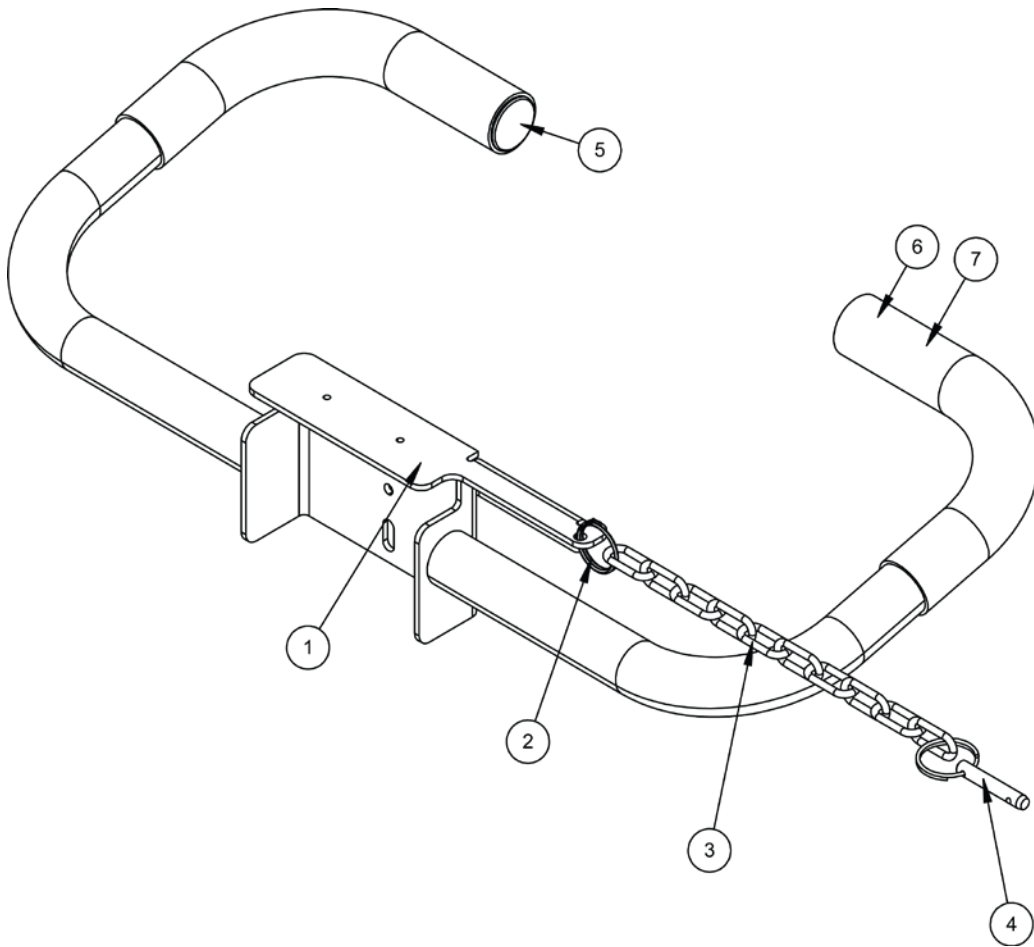

ITEM	QTY	PART NUMBER	DESCRIPTION
1	1	0065-C385-0A	HANDLE WLDMT
2	1	6028-0094	SPLIT RING
3	1	6680-1014	CHAIN
4	1	6028-0093	PIN HITCH
5	2	6540-1149	END CAP
6	2	6540-1070	HAND GRIP
7	1	6560-0009	ADHESIVE

# STATEMENT OF LIMITED WARRANTY

Detecto Scale warrants its equipment to be free from defects in material and workmanship as follows: Detecto warrants to the original purchaser only that it will repair or replace any part of equipment which is defective in material or workmanship for a period of **two (2) years from date of shipment**. Detecto shall be the sole judge of what constitutes a defect.

During the **first ninety (90) days** Detecto may choose to replace the product at no charge to the buyer upon inspection of the returned item.

**After the first ninety (90) days**, upon inspection of the returned item, Detecto will repair or replace it with a remanufactured product. The customer is responsible for paying for the freight both ways.

This warranty does not apply to peripheral equipment not manufactured by Detecto; this equipment will be covered by certain manufacturer's warranty only.

This warranty does not include replacement of expendable or consumable parts. This does not apply to any item which has deteriorated or damaged due to wear, accident, misuse, abuse, improper line voltage, overloading, theft, lightning, fire, water or acts of God, or due to extended storage or exposure while in purchaser's possession. This warranty does not apply to maintenance service. Purchased parts will have a ninety (90) day repair or replacement warranty only.

Detecto may require the product to be returned to the factory; item(s) must be properly packed and shipping charges prepaid. A return authorization number must be obtained for all returns and marked on the outside of all returned packages. Detecto accepts no responsibility for items lost or damaged in transit.

## Conditions Which Void Limited Warranty

This warranty shall not apply to equipment which:

- A.) Has been tampered with, defaced, mishandled or has had repairs and modifications not authorized by Detecto.
- B.) Has had serial number altered, defaced, or removed.
- C.) Has not been properly grounded according to Detecto's recommended procedure.

## Freight Carrier Damage

Claims for equipment damaged in transit must be referred to the freight carrier in accordance with freight carrier regulations.

This warranty sets forth the extent of our liability for breach of any warranty or deficiency in connection with the sale or use of the product. Detecto will not be liable for consequential damages of any nature, including but not limited to, loss of profit, delays or expenses, whether based on tort or contract. Detecto reserves the right to incorporate improvements in material and design without notice and is not obligated to incorporate improvements in equipment previously manufactured.

The foregoing is in lieu of all other warranties, express or implied including any warranty that extends beyond the description of the product including any warranty of merchantability or fitness for a particular purpose. This warranty covers only those Detecto products installed in the forty-eight (48) contiguous continental United States.





Printed in USA

0065-M262-O1 Rev J 09/18